



TOPPERSACADEMY.APP
IIT-JEE/ NEET/ CUET COACHING

JEE Main 2024 April Question Paper with Answer

4th, 5th, 6th, 8th & 9th April (Shift 1 & Shift 2)

JEE Main 2024 – 4th April Shift 1 Question Paper	Page No. 2 to 27
JEE Main 2024 – 4th April Shift 2 Question Paper	Page No. 28 to 52
JEE Main 2024 – 5th April Shift 1 Question Paper	Page No. 53 to 78
JEE Main 2024 – 5th April Shift 2 Question Paper	Page No. 79 to 102
JEE Main 2024 – 6th April Shift 1 Question Paper	Page No. 103 to 129
JEE Main 2024 – 6th April Shift 2 Question Paper	Page No. 130 to 153
JEE Main 2024 – 8th April Shift 1 Question Paper	Page No. 154 to 178
JEE Main 2024 – 8th April Shift 2 Question Paper	Page No. 179 to 202
JEE Main 2024 – 9th April Shift 1 Question Paper	Page No. 203 to 230
JEE Main 2024 – 9th April Shift 2 Question Paper	Page No. 231 to 258

Download more JEE Main Previous Year Question Papers: [Click Here](#)

FINAL JEE-MAIN EXAMINATION – APRIL, 2024

(Held On Thursday 04th April, 2024)

TIME : 9 : 00 AM to 12 : 00 NOON

MATHEMATICS

TEST PAPER WITH SOLUTION

SECTION-A

1. Let $f : \mathbb{R} \rightarrow \mathbb{R}$ be a function given by

$$f(x) = \begin{cases} \frac{1 - \cos 2x}{x^2} & , x < 0 \\ \alpha & , x = 0, \text{ where } \alpha, \beta \in \mathbb{R}. \text{ If} \\ \frac{\beta \sqrt{1 - \cos x}}{x} & , x > 0 \end{cases}$$

f is continuous at $x = 0$, then $\alpha^2 + \beta^2$ is equal to :

- (1) 48 (2) 12
 (3) 3 (4) 6

Ans. (2)

Sol. $f(0^-) = \lim_{x \rightarrow 0^-} \frac{2 \sin^2 x}{x^2} = 2 = \alpha$

$$f(0^+) = \lim_{x \rightarrow 0^+} \beta \times \sqrt{2} \frac{\sin \frac{x}{2}}{2 \frac{x}{2}} = \frac{\beta}{\sqrt{2}} = 2$$

$$\Rightarrow \beta = 2\sqrt{2}$$

$$\alpha^2 + \beta^2 = 4 + 8 = 12$$

2. Three urns A, B and C contain 7 red, 5 black; 5 red, 7 black and 6 red, 6 black balls, respectively. One of the urn is selected at random and a ball is drawn from it. If the ball drawn is black, then the probability that it is drawn from urn A is :

- (1) $\frac{4}{17}$ (2) $\frac{5}{18}$
 (3) $\frac{7}{18}$ (4) $\frac{5}{16}$

Ans. (2)

A	B	C
7R, 5B	5R, 7B	6R, 6B

$$P(B) = \frac{1}{3} \cdot \frac{5}{12} + \frac{1}{3} \cdot \frac{7}{12} + \frac{1}{3} \cdot \frac{6}{12}$$

$$\text{required probability} = \frac{\frac{1}{3} \cdot \frac{5}{12}}{\frac{1}{3} \left[\frac{5}{12} + \frac{7}{12} + \frac{6}{12} \right]} = \frac{5}{18}$$

3. The vertices of a triangle are $A(-1, 3)$, $B(-2, 2)$ and $C(3, -1)$. A new triangle is formed by shifting the sides of the triangle by one unit inwards. Then the equation of the side of the new triangle nearest to origin is :

- (1) $x - y - (2 + \sqrt{2}) = 0$
 (2) $-x + y - (2 - \sqrt{2}) = 0$
 (3) $x + y - (2 - \sqrt{2}) = 0$
 (4) $x + y + (2 - \sqrt{2}) = 0$

Ans. (3)

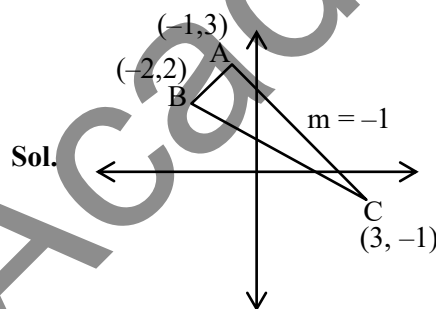

equation of AC $\rightarrow x + y = 2$

equation of line parallel to AC $x + y = d$

$$\left| \frac{d - 2}{\sqrt{2}} \right| = 1$$

$$d = 2 - \sqrt{2}$$

eqⁿ of new required line

$$\boxed{x + y = 2 - \sqrt{2}}$$

4. If the solution $y = y(x)$ of the differential equation $(x^4 + 2x^3 + 3x^2 + 2x + 2)dy - (2x^2 + 2x + 3)dx = 0$ satisfies $y(-1) = -\frac{\pi}{4}$, then $y(0)$ is equal to :

- (1) $-\frac{\pi}{12}$ (2) 0
 (3) $\frac{\pi}{4}$ (4) $\frac{\pi}{2}$

Ans. (3)

Sol.
$$\begin{vmatrix} 1 & \sqrt{2} \sin \alpha & \sqrt{2} \cos \alpha \\ 1 & \sin \alpha & -\cos \alpha \\ 1 & \cos \alpha & \sin \alpha \end{vmatrix} = 0$$

$$\Rightarrow 1 - \sqrt{2} \sin \alpha (\sin \alpha + \cos \alpha) + \sqrt{2} \cos \alpha (\cos \alpha - \sin \alpha) = 0$$

$$\Rightarrow 1 + \sqrt{2} \cos 2\alpha - \sqrt{2} \sin 2\alpha = 0$$

$$\cos 2\alpha - \sin 2\alpha = -\frac{1}{\sqrt{2}}$$

$$\cos\left(2\alpha + \frac{\pi}{4}\right) = -\frac{1}{2}$$

$$2\alpha + \frac{\pi}{4} = 2n\pi \pm \frac{2\pi}{3}$$

$$\alpha + \frac{\pi}{8} = n\pi \pm \frac{\pi}{3}$$

$$n = 0,$$

$$x = \frac{\pi}{3} - \frac{\pi}{8} = \frac{5\pi}{24}$$

8. There are 5 points P_1, P_2, P_3, P_4, P_5 on the side AB, excluding A and B, of a triangle ABC. Similarly there are 6 points P_6, P_7, \dots, P_{11} on the side BC and 7 points $P_{12}, P_{13}, \dots, P_{18}$ on the side CA of the triangle. The number of triangles, that can be formed using the points P_1, P_2, \dots, P_{18} as vertices, is :

- (1) 776 (2) 751
(3) 796 (4) 771

Ans. (2)

Sol. ${}^{18}C_3 - {}^5C_3 - {}^6C_3 - {}^7C_3 = 751$

9. Let $f(x) = \begin{cases} -2, & -2 \leq x \leq 0 \\ x-2, & 0 < x \leq 2 \end{cases}$ and $h(x) = f(|x|) + |f(x)|$.

Then $\int_{-2}^2 h(x) dx$ is equal to :

- (1) 2 (2) 4
(3) 1 (4) 6

Ans. (1)

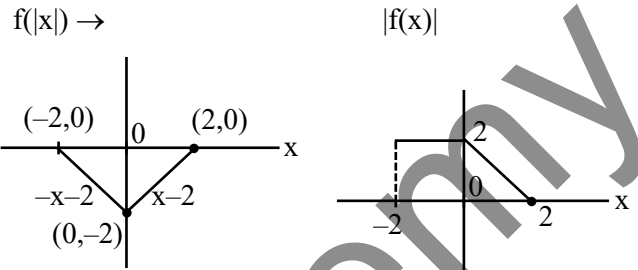
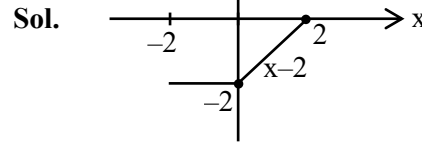

$$h(x) = \begin{cases} x-2+2-x=0, & 0 \leq x \leq 2 \\ -x-2+2=-x & -2 \leq x < 0 \end{cases}$$

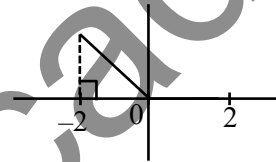

$$\Rightarrow \int_0^2 h(x) dx = 0 \text{ and } \int_{-2}^0 h(x) dx = 2$$

10. The sum of all rational terms in the expansion of

$$\left(2^{\frac{1}{5}} + 5^{\frac{1}{3}}\right)^{15} \text{ is equal to :}$$

- (1) 3133 (2) 633
(3) 931 (4) 6131

Ans. (1)

Sol. $T_{r+1} = {}^{15}C_r \left(\frac{1}{5^3}\right)^r \left(\frac{1}{2^5}\right)^{15-r}$

$$= {}^{15}C_r 5^{\frac{r}{3}} \cdot 2^{\frac{15-r}{5}}$$

$$R = 3\lambda, 15\mu$$

$$\Rightarrow r = 0, 15$$

2 rational terms

$$\Rightarrow {}^{15}C_0 2^3 + {}^{15}C_{15} (5)^5$$

$$= 8 + 3125 = 3133$$

11. Let a unit vector which makes an angle of 60° with $2\hat{i} + 2\hat{j} - \hat{k}$ and an angle of 45° with $\hat{i} - \hat{k}$ be \vec{C} .

Then $\vec{C} + \left(-\frac{1}{2}\hat{i} + \frac{1}{3\sqrt{2}}\hat{j} - \frac{\sqrt{2}}{3}\hat{k}\right)$ is :

- (1) $-\frac{\sqrt{2}}{3}\hat{i} + \frac{\sqrt{2}}{3}\hat{j} + \left(\frac{1}{2} + \frac{2\sqrt{2}}{3}\right)\hat{k}$
 (2) $\frac{\sqrt{2}}{3}\hat{i} + \frac{1}{3\sqrt{2}}\hat{j} - \frac{1}{2}\hat{k}$
 (3) $\left(\frac{1}{\sqrt{3}} + \frac{1}{2}\right)\hat{i} + \left(\frac{1}{\sqrt{3}} - \frac{1}{3\sqrt{2}}\right)\hat{j} + \left(\frac{1}{\sqrt{3}} + \frac{\sqrt{2}}{3}\right)\hat{k}$
 (4) $\frac{\sqrt{2}}{3}\hat{i} - \frac{1}{2}\hat{k}$

Ans. (4)

Sol. $\vec{C} = C_1\hat{i} + C_2\hat{j} + C_3\hat{k}$

$$C_1^2 + C_2^2 + C_3^2 = 1$$

$$\vec{C} \cdot (2\hat{i} + 2\hat{j} - \hat{k}) = |\vec{C}| \sqrt{9} \cos 60^\circ$$

$$2C_1 + 2C_2 - C_3 = \frac{3}{2}$$

$$C_1 - C_3 = 1$$

$$C_1 + 2C_2 = \frac{1}{2}$$

$$C_1 = \frac{\sqrt{2}}{3} + \frac{1}{2}$$

$$C_2 = \frac{-1}{3\sqrt{2}}$$

$$C_3 = \frac{\sqrt{2}}{3} - \frac{1}{2}$$

12. Let the first three terms 2, p and q, with $q \neq 2$, of a G.P. be respectively the 7th, 8th and 13th terms of an A.P. If the 5th term of the G.P. is the nth term of the A.P., then n is equal to

- (1) 151 (2) 169
 (3) 177 (4) 163

Ans. (4)

Sol. $p^2 = 2q$

$$2 = a + 6d \quad \dots(i)$$

$$p = a + 7d \quad \dots(ii)$$

$$q = a + 12d \quad \dots(iii)$$

$$p - 2 = d \quad ((ii) - (i))$$

$$q - p = 5d \quad ((iii) - (ii))$$

$$q - p = 5(p - 2)$$

$$q = 6p - 10$$

$$p^2 = 2(6p - 10)$$

$$p^2 - 12p + 20 = 0$$

$$p = 10, 2$$

$$p = 10 ; q = 50$$

$$d = 8$$

$$a = -46$$

$$2, 10, 50, 250, 1250$$

$$ar^4 = a + (n - 1)d$$

$$1250 = -46 + (n - 1)8$$

$$n = 163$$

13. Let a, b \in R. Let the mean and the variance of 6 observations $-3, 4, 7, -6, a, b$ be 2 and 23, respectively. The mean deviation about the mean of these 6 observations is :

(1) $\frac{13}{3}$ (2) $\frac{16}{3}$

(3) $\frac{11}{3}$ (4) $\frac{14}{3}$

Ans. (1)

Sol. $\frac{\sum x_i}{6} = 2$ and $\frac{\sum x_i^2}{N} - \mu^2 = 23$

$$\alpha + \beta = 10$$

$$\alpha^2 + \beta^2 = 52$$

solving we get $\alpha = 4, \beta = 6$

$$\frac{\sum |x_i - \bar{x}|}{6} = \frac{5 + 2 + 5 + 8 + 2 + 4}{6} = \frac{13}{3}$$

14. If 2 and 6 are the roots of the equation $ax^2 + bx + 1 = 0$, then the quadratic equation, whose roots are $\frac{1}{2a+b}$ and $\frac{1}{6a+b}$, is :

- (1) $2x^2 + 11x + 12 = 0$ (2) $4x^2 + 14x + 12 = 0$
 (3) $x^2 + 10x + 16 = 0$ (4) $x^2 + 8x + 12 = 0$

Ans. (4)

Sol. Sum = $8 = -\frac{b}{a}$

Product = $12 = \frac{1}{a} \Rightarrow a = \frac{1}{12}$

$b = -\frac{2}{3}$

$2a + b = \frac{2}{12} - \frac{2}{3} = -\frac{1}{2}$

$6a + b = \frac{6}{12} - \frac{2}{3} = -\frac{1}{6}$

sum = -8

P = 12

$x^2 + 8x + 12 = 0$

15. Let α and β be the sum and the product of all the non-zero solutions of the equation $(\bar{z})^2 + |z| = 0, z \in \mathbb{C}$. Then $4(\alpha^2 + \beta^2)$ is equal to :

- (1) 6 (2) 4
 (3) 8 (4) 2

Ans. (2)

Sol. $z = x + iy$

$\bar{z} = x - iy$

$\bar{z}^2 = x^2 - y^2 - 2ixy$

$\Rightarrow x^2 - y^2 - 2ixy + \sqrt{x^2 + y^2} = 0$

$\Rightarrow x = 0$ or $y = 0$

$-y^2 + |y| = 0$ $x^2 + |x| = 0$

$|y| = |y|^2$ $\Rightarrow x = 0$

$y = 0, \pm 1$

$\Rightarrow i, -i$ $\Rightarrow \alpha = i - i = 0$

are roots $\beta = i(-i) = 1$

$4(0 + 1) = 4$

16. Let the point, on the line passing through the points P(1, -2, 3) and Q(5, -4, 7), farther from the origin and at a distance of 9 units from the point P, be (α, β, γ) . Then $\alpha^2 + \beta^2 + \gamma^2$ is equal to :

- (1) 155 (2) 150
 (3) 160 (4) 165

Ans. (1)

Sol. PQ line

$\frac{x-1}{4} = \frac{y+2}{-2} = \frac{z-3}{4}$

pt $(4t + 1, -2t - 2, 4t + 3)$

distance² = $16t^2 + 4t^2 + 16t^2 = 81$

$t = \pm \frac{3}{2}$

pt $(7, -5, 9)$

$\alpha^2 + \beta^2 + \gamma^2 = 155$

option (1)

17. A square is inscribed in the circle $x^2 + y^2 - 10x - 6y + 30 = 0$. One side of this square is parallel to $y = x + 3$. If (x_i, y_i) are the vertices of the square, then $\sum(x_i^2 + y_i^2)$ is equal to :

- (1) 148 (2) 156
 (3) 160 (4) 152

Ans. (4)

Sol.

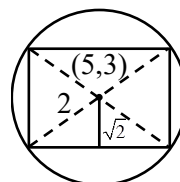

$y = x + c$ &

$x + y + d = 0$

$\left| \frac{5-3+c}{\sqrt{2}} \right| = \sqrt{2}$

$\left| \frac{8+d}{\sqrt{2}} \right| = \sqrt{2}$

$|c + 2| = 2$

$8 + d = \pm 2$

$c = 0, -4$

$d = -10, -6$

pts $(5, 5), (3, 3), (7, 3), (5, 1)$

$\sum(x_i^2 + y_i^2) = 25 + 25 + 9 + 9 + 49 + 9 + 25 + 1$
 $= 152$

Option (4)

18. If the domain of the function $\sin^{-1}\left(\frac{3x-22}{2x-19}\right) + \log_e\left(\frac{3x^2-8x+5}{x^2-3x-10}\right)$ is $(\alpha, \beta]$,

then $3\alpha + 10\beta$ is equal to :

- (1) 97 (2) 100
(3) 95 (4) 98

Ans. (1)

Sol. $-1 \leq \frac{3x-22}{2x-19} \leq 1$ $\frac{3x^2-8x+5}{x^2-3x-10} > 0$

$$x \in \left(5, \frac{41}{5}\right]$$

$$3\alpha + 10\beta = 97$$

Option (1)

19. Let $f(x) = x^5 + 2e^{x/4}$ for all $x \in \mathbb{R}$. Consider a function $g(x)$ such that $(g \circ f)(x) = x$ for all $x \in \mathbb{R}$. Then the value of $8g'(2)$ is :

- (1) 16 (2) 4
(3) 8 (4) 2

Ans. (1)

Sol. $f(x) = 2$

when $x = 0$

$$\therefore g'(f(x)) f'(x) = 1$$

$$g'(2) = \frac{1}{f'(0)}$$

$$\therefore f'(x) = 5x^4 + \frac{2}{4}e^{x/4}$$

$$g'(2) = 2$$

Ans = 16

Option (1)

20. Let $\alpha \in (0, \infty)$ and $A = \begin{bmatrix} 1 & 2 & \alpha \\ 1 & 0 & 1 \\ 0 & 1 & 2 \end{bmatrix}$.

If $\det(\text{adj}(2A - A^T) \cdot \text{adj}(A - 2A^T)) = 2^8$, then $(\det(A))^2$ is equal to :

- (1) 1 (2) 49
(3) 16 (4) 36

Ans. (3)

Sol. $|\text{adj}(A - 2A^T)(2A - A^T)| = 28$

$$|(A - 2A^T)(2A - A^T)| = 24$$

$$|A - 2A^T| |2A - A^T| = \pm 16$$

$$(A - 2A^T)^T = A^T - 2A$$

$$|A - 2A^T| = |A^T - 2A|$$

$$\Rightarrow |A - 2A^T|^2 = 16$$

$$|A - 2A^T| = \pm 4$$

$$\begin{bmatrix} 1 & 2 & \alpha \\ 1 & 0 & 1 \\ 0 & 1 & 2 \end{bmatrix} - \begin{bmatrix} 2 & 2 & 0 \\ 4 & 0 & 2 \\ 2\alpha & 2 & 4 \end{bmatrix}$$

$$\begin{vmatrix} -1 & 0 & \alpha \\ -3 & 0 & -1 \\ -2\alpha & -1 & -2 \end{vmatrix}$$

$$1 + 3\alpha = 4$$

$$3\alpha = 3$$

$$\alpha = 1$$

$$|A| = \begin{vmatrix} 1 & 2 & 1 \\ 1 & 0 & 1 \\ 0 & 1 & 2 \end{vmatrix} = -1 - 3 = -4$$

$$|A|^2 = 16$$

SECTION-B

21. If $\lim_{x \rightarrow 1} \frac{(5x+1)^{1/3} - (x+5)^{1/3}}{(2x+3)^{1/2} - (x+4)^{1/2}} = \frac{m\sqrt{5}}{n(2n)^{2/3}}$, where

$\text{gcd}(m, n) = 1$, then $8m + 12n$ is equal to _____

Ans. (100)

Sol. $\lim_{x \rightarrow 1} \frac{\frac{1}{3}(5x+1)^{-2/3} \cdot 5 - \frac{1}{3}(x+5)^{-2/3}}{\frac{1}{2}(2x+3)^{-1/2} \cdot 2 - \frac{1}{2}(x+4)^{-1/2}}$

$$= \frac{8\sqrt{5}}{3 \cdot 6^{2/3}} \quad \begin{matrix} m = 8 \\ n = 3 \end{matrix}$$

$$8m + 12n = 100$$

22. In a survey of 220 students of a higher secondary school, it was found that at least 125 and at most 130 students studied Mathematics; at least 85 and at most 95 studied Physics; at least 75 and at most 90 studied Chemistry; 30 studied both Physics and Chemistry; 50 studied both Chemistry and Mathematics; 40 studied both Mathematics and Physics and 10 studied none of these subjects. Let m and n respectively be the least and the most number of students who studied all the three subjects. Then $m + n$ is equal to _____

Ans. (45)

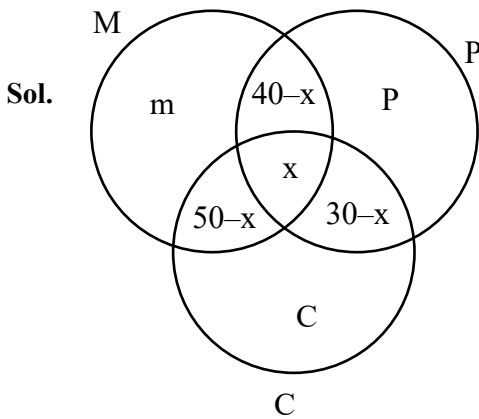

$$125 \leq m + 90 - x \leq 130$$

$$85 \leq P + 70 - x \leq 95$$

$$75 \leq C + 80 - x \leq 90$$

$$m + P + C + 120 - 2x = 210$$

$$\Rightarrow 15 \leq x \leq 45 \text{ \& } 30 - x \geq 0$$

$$\Rightarrow 15 \leq x \leq 30$$

$$30 + 15 = 45$$

23. Let the solution $y = y(x)$ of the differential equation $\frac{dy}{dx} - y = 1 + 4\sin x$ satisfy $y(\pi) = 1$. Then

$$y\left(\frac{\pi}{2}\right) + 10 \text{ is equal to } \underline{\hspace{2cm}}$$

Ans. (7)

Sol. $ye^{-x} = \int (e^{-x} + 4e^{-x} \sin x) dx$

$$ye^{-x} = -e^{-x} - 2(e^{-x} \sin x - e^{-x} \cos x) + C$$

$$y = -1 - 2(\sin x + \cos x) + ce^x$$

$$\because y(\pi) = 1 \Rightarrow c = 0$$

$$y(\pi/2) = -1 - 2 = -3$$

$$\text{Ans} = 10 - 3 = 7$$

24. If the shortest distance between the lines $\frac{x+2}{2} = \frac{y+3}{3} = \frac{z-5}{4}$ and $\frac{x-3}{1} = \frac{y-2}{-3} = \frac{z+4}{2}$ is

$$\frac{38}{3\sqrt{5}}k \quad \text{and} \quad \int_0^k [x^2] dx = \alpha - \sqrt{\alpha}, \quad \text{where } [x]$$

denotes the greatest integer function, then $6\alpha^3$ is equal to _____

Ans. (48)

Sol. $\frac{38}{3\sqrt{5}}\hat{k} = \frac{(5\hat{i} + 5\hat{j} - 9\hat{k})}{\sqrt{5}} \cdot \begin{vmatrix} \hat{i} & \hat{j} & \hat{k} \\ 2 & 3 & 4 \\ 1 & -3 & 2 \end{vmatrix}$

$$\frac{38}{3\sqrt{5}}\hat{k} = \frac{19}{\sqrt{5}}$$

$$k = \frac{19}{\sqrt{5}}$$

$$k = \frac{3}{2}$$

$$\int_0^{3/2} [x^2] dx = \int_0^1 0 + \int_1^{\sqrt{2}} 1 + \int_{\sqrt{2}}^{3/2} 2$$

$$= \sqrt{2} - 1 + 2\left(\frac{3}{2} - \sqrt{2}\right)$$

$$= 2 - \sqrt{2}$$

$$\alpha = 2$$

$$\Rightarrow 6\alpha^3 = 48$$

25. Let A be a square matrix of order 2 such that $|A| = 2$ and the sum of its diagonal elements is -3 . If the points (x, y) satisfying $A^2 + xA + yI = 0$ lie on a hyperbola, whose transverse axis is parallel to the x -axis, eccentricity is e and the length of the latus rectum is ℓ , then $e^4 + \ell^4$ is equal to _____

Ans. (Bouns)

NTA Ans. (25)

Sol. Given $|A| = 2$

$$\text{trace } A = -3$$

$$\text{and } A^2 + xA + yI = 0$$

$$\Rightarrow x = 3, y = 2$$

so, information is incomplete to determine eccentricity of hyperbola (e) and length of latus rectum of hyperbola (ℓ)

26. Let $a = 1 + \frac{{}^2C_2}{{}^3!} + \frac{{}^3C_2}{{}^4!} + \frac{{}^4C_2}{{}^5!} + \dots$,
 $b = 1 + \frac{{}^1C_0 + {}^1C_1}{{}^1!} + \frac{{}^2C_0 + {}^2C_1 + {}^2C_2}{{}^2!} + \frac{{}^3C_0 + {}^3C_1 + {}^3C_2 + {}^3C_3}{{}^3!} + \dots$

Then $\frac{2b}{a^2}$ is equal to _____

Ans. (8)

Sol. $f(x) = 1 + \frac{(1+x)}{1!} + \frac{(1+x)^2}{2!} + \frac{(1+x)^3}{3!} + \dots$
 $\frac{e^{(1+x)}}{1+x} = \frac{1}{1+x} + 1 + \frac{(1+x)}{2!} + \frac{(1+x)^2}{3!} + \frac{(1+x)^3}{4!} + \dots$

coef x^2 in RHS : $1 + \frac{{}^2C_2}{3} + \frac{{}^3C_2}{4} + \dots = a$

coeff. x^2 in L.H.S.

$$e \left(1 + x + \frac{x^2}{2!} \right) \dots \left(1 - x + \frac{x^2}{2!} \dots \right)$$

is $e - e + \frac{e}{2!} = a$

$$b = 1 + \frac{2}{1!} + \frac{2^2}{2!} + \frac{2^3}{3!} + \dots = e^2$$

$$\frac{2b}{a^2} = 8$$

27. Let A be a 3×3 matrix of non-negative real elements such that $A \begin{bmatrix} 1 \\ 1 \\ 1 \end{bmatrix} = 3 \begin{bmatrix} 1 \\ 1 \\ 1 \end{bmatrix}$. Then the maximum value of $\det(A)$ is _____

Ans. (27)

Sol. Let $A = \begin{bmatrix} a_1 & a_2 & a_3 \\ b_1 & b_2 & b_3 \\ c_1 & c_2 & c_3 \end{bmatrix}$

$$A \begin{bmatrix} 1 \\ 1 \\ 1 \end{bmatrix} = 3 \begin{bmatrix} 1 \\ 1 \\ 1 \end{bmatrix}$$

$$\Rightarrow a_1 + a_2 + a_3 = 3 \quad \dots(1)$$

$$\Rightarrow b_1 + b_2 + b_3 = 3 \quad \dots(2)$$

$$\Rightarrow c_1 + c_2 + c_3 = 3 \quad \dots(3)$$

Now,

$$|A| = (a_1b_2c_3 + a_2b_3c_1 + a_3b_1c_2)$$

$$- (a_3b_2c_1 + a_2b_1c_3 + a_1b_3c_2)$$

\therefore From above in formation, clearly $|A|_{\max} = 27$, when $a_1 = 3, b_2 = 3, c_3 = 3$

28. Let the length of the focal chord PQ of the parabola $y^2 = 12x$ be 15 units. If the distance of PQ from the origin is p, then $10p^2$ is equal to _____

Ans. (72)

Sol.

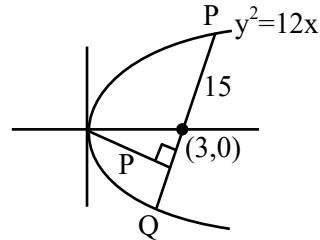

length of focal chord = $4a \operatorname{cosec}^2\theta = 15$

$$12 \operatorname{cosec}^2\theta = 15$$

$$\sin^2\theta = \frac{4}{5}$$

$$\tan^2\theta = 4$$

$$\tan\theta = 2$$

equation $\frac{y-0}{x-3} = 2$

$$y = 2x - 6$$

$$2x - y - 6 = 0$$

$$P = \frac{6}{\sqrt{5}}$$

$$10p^2 = 10 \cdot \frac{36}{5} = 72$$

29. Let ABC be a triangle of area $15\sqrt{2}$ and the vectors $\overline{AB} = \hat{i} + 2\hat{j} - 7\hat{k}$, $\overline{BC} = a\hat{i} + b\hat{j} + c\hat{k}$ and $\overline{AC} = 6\hat{i} + d\hat{j} - 2\hat{k}$, $d > 0$. Then the square of the length of the largest side of the triangle ABC is

Ans. (54)

Sol.

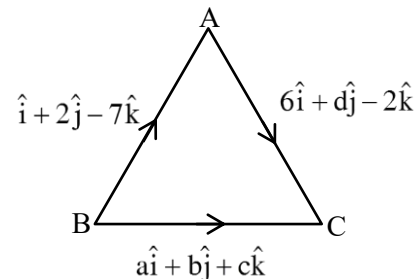

$$\text{Area} = \frac{1}{2} \begin{vmatrix} \hat{i} & \hat{j} & \hat{k} \\ 1 & 2 & -7 \\ 6 & d & -2 \end{vmatrix} = 15\sqrt{2}$$

$$(-4 + 7d)\hat{i} - \hat{j}(-2 + 42) + \hat{k}(d - 12)$$

$$(7d - 4)^2 + (40)^2 + (d - 12)^2 = 1800$$

$$50d^2 - 80d - 40 = 0$$

$$5d^2 - 8d - 4 = 0$$

$$5d^2 - 10d - 2d - 4$$

$$5d(d - 2) + 2(d - 2) = 0$$

$$d = 2 \text{ or } d = -\frac{2}{5}$$

$$\therefore d > 0, d = 2$$

$$(a + 1)\hat{i} + (b + 2)\hat{j} + (c - 7)\hat{k} = 6\hat{i} + 2\hat{j} - 2\hat{k}$$

$$a + 1 = 6 \text{ \& } b + 2 = 2, c - 7 = -2$$

$$a = 5 \quad b = 0 \quad c = 5$$

$$|AB| = \sqrt{1 + 4 + 49} = \sqrt{54}$$

$$|BC| = \sqrt{25 + 25} = \sqrt{50}$$

$$|AC| = \sqrt{86 + 4 + 4} = \sqrt{44}$$

Ans. 54

30. If $\int_0^{\frac{\pi}{4}} \frac{\sin^2 x}{1 + \sin x \cos x} dx = \frac{1}{a} \log_e \left(\frac{a}{3} \right) + \frac{\pi}{b\sqrt{3}}$, where $a,$

$b \in \mathbb{N}$, then $a + b$ is equal to _____

Ans. (8)

Sol. $\int_0^{\frac{\pi}{2}} \frac{\sin^2 x}{1 + \frac{1}{2} \sin 2x} dx = \int_0^{\frac{\pi}{4}} \frac{1 - \cos 2x}{2 + \sin 2x} dx$

$$\int \frac{1}{2 + \sin 2x} - \int \frac{\cos 2x}{2 + \sin 2x}$$

(I₁) (I₂)

$$(I_1) = \int \frac{dx}{2 + \frac{2 \tan x}{1 + \tan^2 x}}$$

$$\int_0^{\frac{\pi}{4}} \frac{\sec^2 x dx}{2 \tan^2 x + 2 \tan x + 2}$$

$$\tan x = t$$

$$\frac{1}{2} \int_0^1 \frac{dt}{\left(t + \frac{1}{2}\right)^2 + \frac{3}{4}} = \frac{\pi}{6\sqrt{3}}$$

$$I_2 = \int_0^{\pi/4} \frac{\cos 2x}{2 + \sin 2x} dx = \frac{1}{2} \left(\ln \frac{3}{2} \right)$$

$$I_1 - I_2 = \frac{1}{\sqrt{3}} \frac{\pi}{6} + \frac{1}{2} \ln \frac{2}{3}$$

$$\Rightarrow a = 2, b = 6$$

Ans. 8

PHYSICS

TEST PAPER WITH SOLUTION

SECTION-A

31. An electron is projected with uniform velocity along the axis inside a current carrying long solenoid. Then :
- (1) the electron will be accelerated along the axis.
 - (2) the electron will continue to move with uniform velocity along the axis of the solenoid.
 - (3) the electron path will be circular about the axis.
 - (4) the electron will experience a force at 45° to the axis and execute a helical path.

Ans. (2)

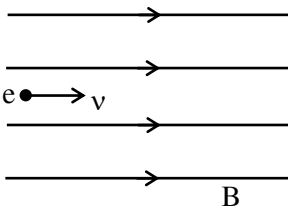

Sol.

Since $\vec{v} \parallel \vec{B}$ so force on electron due to magnetic field is zero. So it will move along axis with uniform velocity.

32. The electric field in an electromagnetic wave is given by $\vec{E} = \hat{i}40 \cos \omega \left(t - \frac{z}{c} \right) \text{NC}^{-1}$. The magnetic field induction of this wave is (in SI unit):

- (1) $\vec{B} = \hat{i} \frac{40}{c} \cos \omega \left(t - \frac{z}{c} \right)$
- (2) $\vec{B} = \hat{j} 40 \cos \omega \left(t - \frac{z}{c} \right)$
- (3) $\vec{B} = \hat{k} \frac{40}{c} \cos \omega \left(t - \frac{z}{c} \right)$
- (4) $\vec{B} = \hat{j} \frac{40}{c} \cos \omega \left(t - \frac{z}{c} \right)$

Ans. (4)

Sol. $\vec{E} = \hat{i}40 \cos \omega \left(t - \frac{z}{c} \right)$

\vec{E} is along +x direction

\vec{v} is along +z direction

So direction of \vec{B} will be along +y and magnitude of B will be $\frac{E}{c}$

So answer is $\frac{40}{c} \cos \omega \left(t - \frac{z}{c} \right) \hat{j}$

33. Which of the following nuclear fragments corresponding to nuclear fission between neutron (${}_0^1\text{n}$) and uranium isotope (${}_{92}^{235}\text{U}$) is correct:

- (1) ${}_{56}^{144}\text{Ba} + {}_{36}^{89}\text{Kr} + 4{}_0^1\text{n}$
- (2) ${}_{56}^{140}\text{Xe} + {}_{38}^{94}\text{Sr} + 3{}_0^1\text{n}$
- (3) ${}_{51}^{153}\text{Sb} + {}_{41}^{99}\text{Nb} + 3{}_0^1\text{n}$
- (4) ${}_{56}^{144}\text{Ba} + {}_{36}^{89}\text{Kr} + 3{}_0^1\text{n}$

Ans. (4)

Sol. Balancing mass number and atomic number

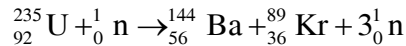

34. In an experiment to measure focal length (f) of convex lens, the least counts of the measuring scales for the position of object (u) and for the position of image (v) are Δu and Δv , respectively. The error in the measurement of the focal length of the convex lens will be :

- (1) $\frac{\Delta u}{u} + \frac{\Delta v}{v}$
- (2) $f^2 \left[\frac{\Delta u}{u^2} + \frac{\Delta v}{v^2} \right]$
- (3) $2f \left[\frac{\Delta u}{u} + \frac{\Delta v}{v} \right]$
- (4) $f \left[\frac{\Delta u}{u} + \frac{\Delta v}{v} \right]$

Ans. (2)

Sol. $f^{-1} = v^{-1} - u^{-1}$

$$-f^{-2} df = -v^{-2} dv - u^{-2} du$$

$$\frac{df}{f^2} = \frac{dv}{v^2} + \frac{du}{u^2}$$

$$df = f^2 \left[\frac{dv}{v^2} + \frac{du}{u^2} \right]$$

35. Given below are two statements :

Statement I : When speed of liquid is zero everywhere, pressure difference at any two points depends on equation $P_1 - P_2 = \rho g (h_2 - h_1)$

Statement II : In ventury tube shown $2gh = v_1^2 - v_2^2$

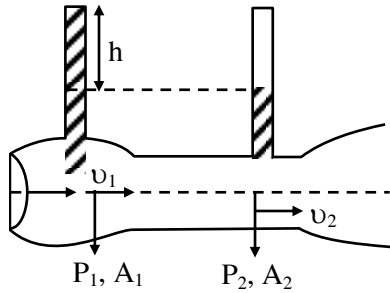

In the light of the above statements, choose the most appropriate answer from the options given below.

- (1) Both Statement I and Statement II are correct.
- (2) Statement I is incorrect but Statement II is correct.
- (3) Both Statement I and Statement II are incorrect.
- (4) Statement I is correct but Statement II is incorrect.

Ans. (4)

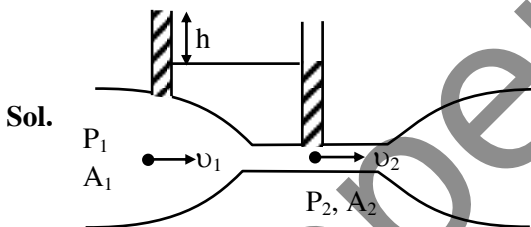

Sol.

Applying Bernoulli's equation

$$P_1 + \rho gh_1 + \frac{1}{2} \rho v_1^2 = P_2 + \rho gh_2 + \frac{1}{2} \rho v_2^2$$

[h_1 & h_2 are height of point from any reference level]

Given $v_1 = v_2 = 0$ (for statement-1)

$$\therefore P_1 - P_2 = \rho g(h_2 - h_1)$$

For statement-2

$$P_1 + \frac{1}{2} \rho v_1^2 = P_2 + \frac{1}{2} \rho v_2^2$$

$$P_1 - P_2 = \rho gh$$

$$P_1 - P_2 = \frac{1}{2} \rho v_2^2 - \frac{1}{2} \rho v_1^2$$

$$\rho gh = \frac{1}{2} \rho v_2^2 - \frac{1}{2} \rho v_1^2$$

$$2gh = v_2^2 - v_1^2$$

Hence answer (4)

36. The resistances of the platinum wire of a platinum resistance thermometer at the ice point and steam point are 8Ω and 10Ω respectively. After inserting in a hot bath of temperature 400°C , the resistance of platinum wire is :

- (1) 2Ω
- (2) 16Ω
- (3) 8Ω
- (4) 10Ω

Ans. (2)

Sol. Given $R_0 = 8\Omega$, $R_{100} = 10\Omega$

$$\therefore R_{100} = R_0 (1 + \alpha \Delta T)$$

$$\text{Also, } R_{400} = R_0 (1 + \alpha \Delta T^1)$$

$$\therefore 10 = 8 (1 + \alpha \times 100) \Rightarrow 100\alpha = \frac{1}{4}$$

$$\therefore R_{400} = 8 (1 + 400\alpha) = 8 (1 + 1) = 16\Omega$$

Hence option (2)

37. A metal wire of uniform mass density having length L and mass M is bent to form a semicircular arc and a particle of mass m is placed at the centre of the arc. The gravitational force on the particle by the wire is:

$$(1) \frac{GMm\pi}{2L^2} \quad (2) 0$$

$$(3) \frac{GmM\pi^2}{L^2} \quad (4) \frac{2GmM\pi}{L^2}$$

Ans. (4)

Sol.

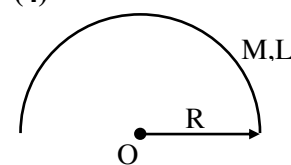

We have $R = \frac{L}{\pi}$

$$g_0 = \frac{2G \frac{M}{L}}{R} = \frac{2GM\pi}{L^2}$$

$$\therefore F_m = mg_0 = \frac{2GM\pi m}{L^2}$$

Hence option (4)

38. On celcius scale the temperature of body increases by 40°C . The increase in temperature on Fahrenheit scale is:

- (1) 70°F
- (2) 68°F
- (3) 72°F
- (4) 75°F

Ans. (3)

Sol. We know that per $^\circ\text{C}$ change is equivalent to 1.8° change in $^\circ\text{F}$.

$\therefore 40^\circ$ change on celcius scale will corresponds to 72° change on Fahrenheit scale.

Hence option (3)

39. An effective power of a combination of 5 identical convex lenses which are kept in contact along the principal axis is 25 D. Focal length of each of the convex lens is :

- (1) 20 cm
- (2) 50 cm
- (3) 500 cm
- (4) 25 cm

Ans. (1)

Sol. We know that $P_{eq} = \sum P_i$

\therefore given all lenses are identical

$$\therefore 5P = 25\text{D}$$

$$\therefore P = 5\text{D}$$

$$\therefore \frac{1}{f} = 5 \Rightarrow f = \frac{1}{5} \text{ m} = 20\text{cm}$$

Hence option (1)

40. Which figure shows the correct variation of applied potential difference (V) with photoelectric current (I) at two different intensities of light ($I_1 < I_2$) of same wavelengths :

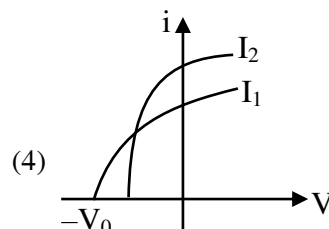
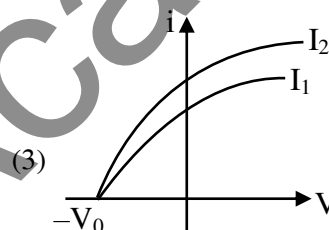
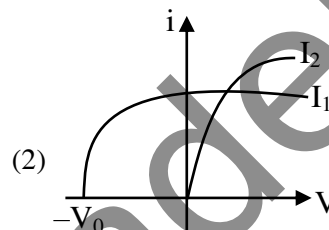
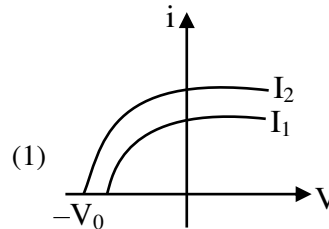

Ans. (3)

Sol. Given lights are of same wavelength.

Hence stopping potential will remain same.

Since $I_2 > I_1$, hence saturation current corresponding to I_2 will be greater than that corresponding to I_1 .

Hence option (3)

41. A wooden block, initially at rest on the ground, is pushed by a force which increases linearly with time t . Which of the following curve best describes acceleration of the block with time :

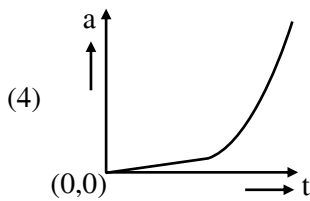
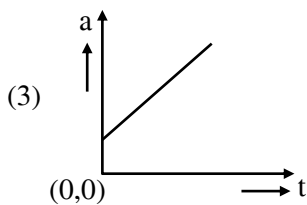
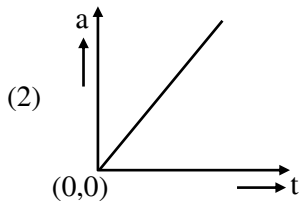
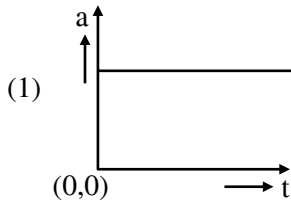

Ans. (2)

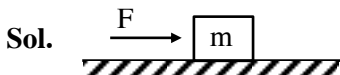

$$F = ma \Rightarrow a = \frac{F}{m} = \frac{kt}{m}$$

a vs t will be straight line passing through origin.

Since option (2).

42. If a rubber ball falls from a height h and rebounds upto the height of $h/2$. The percentage loss of total energy of the initial system as well as velocity ball before it strikes the ground, respectively, are :

- (1) 50%, $\sqrt{\frac{gh}{2}}$ (2) 50%, \sqrt{gh}
 (3) 40%, $\sqrt{2gh}$ (4) 50%, $\sqrt{2gh}$

Ans. (4)

Sol. Velocity just before collision = $\sqrt{2gh}$

Velocity just after collision = $\sqrt{2g\left(\frac{h}{2}\right)}$

$$\begin{aligned} \therefore \Delta KE &= \frac{1}{2} m (2gh) - \frac{1}{2} mgh \\ &= \frac{1}{2} mgh \end{aligned}$$

\therefore % loss in energy

$$= \frac{\Delta KE}{KE_i} \times 100 = \frac{\frac{1}{2} mgh}{\frac{1}{2} mg2h} \times 100 = 50\%$$

Hence option (4)

43. The equation of stationary wave is :

$$y = 2a \sin\left(\frac{2\pi nt}{\lambda}\right) \cos\left(\frac{2\pi x}{\lambda}\right)$$

Which of the following is NOT correct

- (1) The dimensions of nt is [L]
 (2) The dimensions of n is $[LT^{-1}]$
 (3) The dimensions of n/λ is [T]
 (4) The dimensions of x is [L]

Ans. (3)

Sol. Comparing the given equation with standard

equation of standing $\frac{2\pi n}{\lambda} = \omega$ & $\frac{2\pi}{\lambda} = k$

$$\left[\frac{n}{\lambda}\right] = [\omega] = T^{-1}$$

$$[nt] = [\lambda] = L$$

$$[n] = [\lambda\omega] = LT^{-1}$$

$$[x] = [\lambda] = L$$

Hence option (3)

44. A body travels 102.5 m in n^{th} second and 115.0 m in $(n + 2)^{\text{th}}$ second. The acceleration is :

- (1) 9 m/s^2 (2) 6.25 m/s^2
 (3) 12.5 m/s^2 (4) 5 m/s^2

Ans. (2)

Sol. Given, $102.5 = u + \frac{a}{2}(2n - 1)$ &

$$115 = u + \frac{a}{2}(2n + 3)$$

$$\Rightarrow 102.5 = u + an - \frac{a}{2} \text{ \&}$$

$$115 = u + an + \frac{3a}{2}$$

$$12.5 = 2a \Rightarrow a = 6.25 \text{ m/s}^2$$

Hence option (2)

45. To measure the internal resistance of a battery, potentiometer is used. For $R = 10 \Omega$, the balance point is observed at $\ell = 500 \text{ cm}$ and for $R = 1 \Omega$ the balance point is observed at $\ell = 400 \text{ cm}$. The internal resistance of the battery is approximately :

- (1) 0.2Ω (2) 0.4Ω
 (3) 0.1Ω (4) 0.3Ω

Ans. (4)

Sol. Let potential gradient be λ .

$$\therefore i \times 10 = \lambda \times 500 = \varepsilon - ir_s$$

$$\Rightarrow 500\lambda = \varepsilon - 50\lambda r_s$$

Also,

$$i' \times 1 = \lambda \times 400 = \varepsilon - i'r_s$$

$$\Rightarrow 400\lambda = \varepsilon - 400\lambda r_s$$

$$\therefore 100\lambda = 350\lambda r_s \Rightarrow r_s = \frac{10}{35} \approx 0.3\Omega$$

Hence option (4)

46. An infinitely long positively charged straight thread has a linear charge density $\lambda \text{ Cm}^{-1}$. An electron revolves along a circular path having axis along the length of the wire. The graph that correctly represents the variation of the kinetic energy of electron as a function of radius of circular path from the wire is :

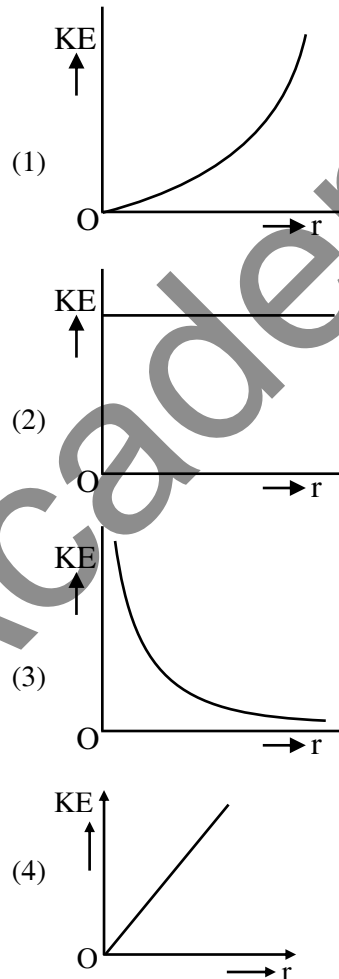

Ans. (2)

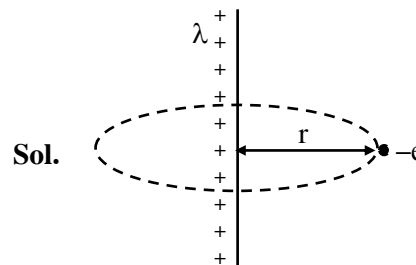

Electric field E at a distance r due to infinite long wire is $E = \frac{2k\lambda}{r}$

Force of electron $\Rightarrow F = eE$

$$F = e \left(\frac{2k\lambda}{r} \right)$$

$$F = \frac{2k\lambda e}{r}$$

This force will provide required centripetal force

$$F = \frac{mv^2}{r} = \frac{2k\lambda e}{r}$$

$$v = \sqrt{\frac{2k\lambda e}{m}}$$

$$\begin{aligned} KE &= \frac{1}{2}mv^2 = \frac{1}{2}m \left(\frac{2k\lambda e}{m} \right) \\ &= k\lambda e \end{aligned}$$

This is constant so option (2) is correct.

47. The value of net resistance of the network as shown in the given figure is :

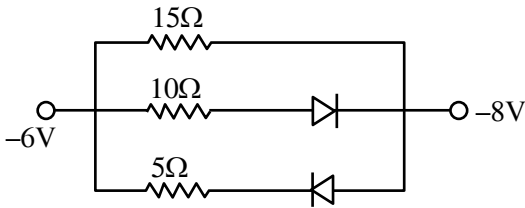

- (1) $\left(\frac{5}{2}\right)\Omega$ (2) $\left(\frac{15}{4}\right)\Omega$
 (3) 6Ω (4) $\left(\frac{30}{11}\right)\Omega$

Ans. (3)

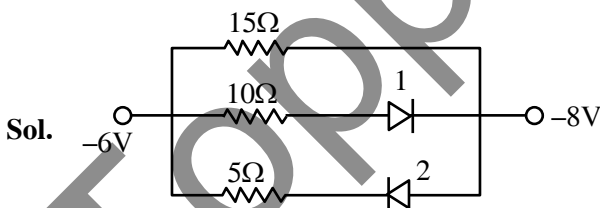

Diode 2 is in reverse bias
 So current will not flow in branch of 2nd diode, So we can assume it to be broken wire.
 Diode 1 is in forward bias
 So it will behave like conducting wire. So new circuit will be

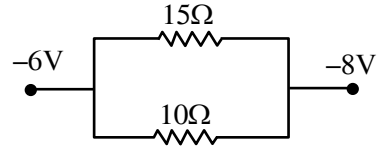

$$R_{eq} = \frac{15 \times 10}{15 + 10} = \frac{15 \times 10}{25} = 6\Omega$$

Correct answer (3)

48. P-T diagram of an ideal gas having three different densities ρ_1, ρ_2, ρ_3 (in three different cases) is shown in the figure. Which of the following is correct :

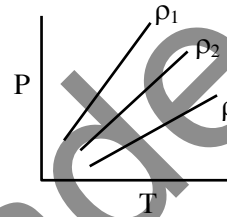

- (1) $\rho_2 < \rho_3$ (2) $\rho_1 > \rho_2$
 (3) $\rho_1 < \rho_2$ (4) $\rho_1 = \rho_2 = \rho_3$

Ans. (2)

Sol. For ideal gas

$$PV = nRT$$

$$PV = \frac{m}{M}RT$$

$$P = \left(\frac{M}{V} \right) \frac{RT}{M}$$

$$P = \frac{\rho RT}{M}$$

(Where m is mass of gas and M is molecular mass of gas)

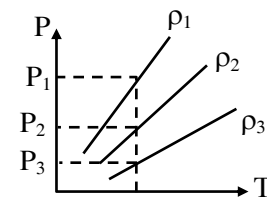

for same temperature $P_1 > P_2 > P_3$

So $\rho_1 > \rho_2 > \rho_3$

So correct answer is (2)

49. The co-ordinates of a particle moving in x-y plane are given by :

$$x = 2 + 4t, y = 3t + 8t^2.$$

The motion of the particle is :

- (1) non-uniformly accelerated.
- (2) uniformly accelerated having motion along a straight line.
- (3) uniform motion along a straight line.
- (4) uniformly accelerated having motion along a parabolic path.

Ans. (4)

Sol. $x = 2 + 4t$

$$\frac{dx}{dt} = v_x = 4$$

$$\frac{dv_x}{dt} = a_x = 0$$

$$y = 3t + 8t^2$$

$$\frac{dy}{dt} = v_y = 3 + 16t$$

$$\frac{dv_y}{dt} = a_y = 16$$

the motion will be uniformly accelerated motion.

For path

$$x = 2 + 4t$$

$$\frac{(x-2)}{4} = t$$

Put this value of t in equation of y

$$y = 3\left(\frac{x-2}{4}\right) + 8\left(\frac{x-2}{4}\right)^2$$

this is a quadratic equation so path will be parabola.

Correct answer (4)

50. In an ac circuit, the instantaneous current is zero, when the instantaneous voltage is maximum. In this case, the source may be connected to :

- A. pure inductor.
 - B. pure capacitor.
 - C. pure resistor.
 - D. combination of an inductor and capacitor.
- Choose the correct answer from the options given below :

- (1) A, B and C only
- (2) B, C and D only
- (3) A and B only
- (4) A, B and D only

Ans. (4)

Sol. This is possible when phase difference is $\frac{\pi}{2}$ between current and voltage so correct answer will be (4)

SECTION-B

51. An infinite plane sheet of charge having uniform surface charge density $+\sigma_s$ C/m² is placed on x-y plane. Another infinitely long line charge having uniform linear charge density $+\lambda_e$ C/m is placed at $z = 4$ m plane and parallel to y-axis. If the magnitude values $|\sigma_s| = 2|\lambda_e|$ then at point $(0, 0, 2)$, the ratio of magnitudes of electric field values due to sheet charge to that of line charge is $\pi\sqrt{n} : 1$. The value of n is _____.

Ans. (16)

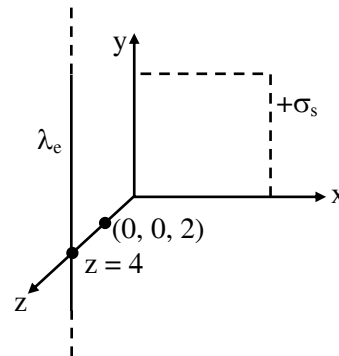

Sol.

$$\begin{aligned} \frac{E_s}{E_\ell} &= \frac{\sigma}{2\epsilon_0} \times \frac{2\pi\epsilon_0 r}{\lambda} \\ &= \frac{\pi \times \sigma r}{\lambda} \\ &= \frac{\pi \times 2\lambda \times 2}{\lambda} = \frac{4\pi}{1} \end{aligned}$$

$$\therefore n = 16$$

52. A hydrogen atom changes its state from $n = 3$ to $n = 2$. Due to recoil, the percentage change in the wave length of emitted light is approximately 1×10^{-n} . The value of n is _____.

[Given $Rhc = 13.6$ eV, $hc = 1242$ eV nm, $h = 6.6 \times 10^{-34}$ J s, mass of the hydrogen atom $= 1.6 \times 10^{-27}$ kg]

Ans. (7)

Sol. $\Delta E = 13.6 \left(\frac{1}{2^2} - \frac{1}{3^2} \right) = 1.9$ eV

$$\Delta E = \frac{hc}{\lambda}$$

$$\lambda = \frac{hc}{\Delta E}$$

$$P_i = P_f$$

$$0 = -mv + \frac{h}{\lambda'}$$

$$\Rightarrow v = \frac{h}{m\lambda'}$$

$$\Delta E = \frac{1}{2}mv^2 + \frac{hc}{\lambda'}$$

$$= \frac{1}{2}m \left(\frac{h}{m\lambda'} \right)^2 + \frac{hc}{\lambda'}$$

Now

$$\Delta E = \frac{h^2}{2m\lambda'^2} + \frac{hc}{\lambda'}$$

$$\lambda'^2 \Delta E - hc\lambda' - \frac{h^2}{2m} = 0$$

$$\lambda' = \frac{hc \pm \sqrt{h^2c^2 + \frac{4\Delta E h^2}{2m}}}{2\Delta E}$$

$$\lambda' = \frac{hc \pm hc \sqrt{1 + \frac{2\Delta E}{mc^2}}}{2\Delta E}$$

$$\frac{\lambda'}{\lambda} = \frac{1 + \left(1 + \frac{2\Delta E}{mc^2}\right)^{\frac{1}{2}}}{2} = \frac{1 + 1 + \frac{\Delta E}{mc^2}}{2}$$

$$\frac{\lambda'}{\lambda} = 1 + \frac{\Delta E}{2mc^2}$$

$$\frac{\lambda' - \lambda}{\lambda} = \frac{\Delta E}{2mc^2} = \frac{1.9 \times 1.6 \times 10^{-19}}{2 \times 1.67 \times 10^{-27} \times 9 \times 10^{16}} = 10^{-9}$$

$$\therefore \% \text{ change} \approx 10^{-7}$$

Correct answer 7

53. The magnetic field existing in a region is given by $\vec{B} = 0.2(1 + 2x)\hat{k}$ T. A square loop of edge 50 cm carrying 0.5 A current is placed in x-y plane with its edges parallel to the x-y axes, as shown in figure. The magnitude of the net magnetic force experienced by the loop is _____ mN.

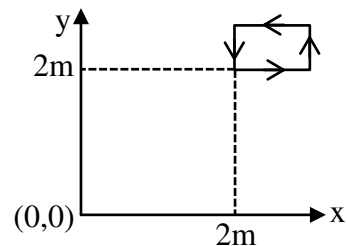

Ans. (50)

- Sol. Force on segment parallel to x-axis will cancel each other. Hence F_{net} will be due to portion parallel to y-axis.

$$\begin{aligned} F &= 0.5 \times 0.5 \times 6 \times 0.2 - 0.5 \times 0.5 \times 0.2 \times 5 \\ &= 0.5 \times 0.5 \times 0.2 \\ &= 0.25 \times 0.2 \\ &= 50 \times 10^{-3} \text{ N} \\ &= 50 \text{ mN} \end{aligned}$$

54. A alternating current at any instant is given by $i = \left[6 + \sqrt{56} \sin \left(100\pi t + \frac{\pi}{3} \right) \right]$ A. The rms value of the current is _____ A.

Ans. (8)

Sol.
$$I_{\text{rms}} = \sqrt{\frac{\int i^2 dt}{\int dt}}$$

$$I_{\text{rms}} = \sqrt{(6)^2 + \frac{(\sqrt{56})^2}{2}}$$

$$= \sqrt{36 + 28}$$

$$= \sqrt{64}$$

$$= 8 \text{ A}$$

55. Twelve wires each having resistance 2Ω are joined to form a cube. A battery of 6 V emf is joined across point a and c. The voltage difference between e and f is _____ V.

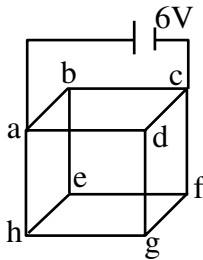

Ans. (1)

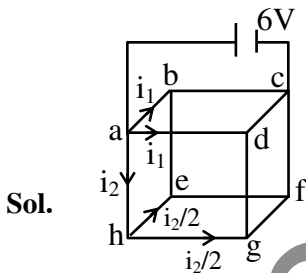

From symmetry, current through e-b & g-d = 0

$$\therefore R_{\text{eq}} = \frac{3}{4} \times R = \frac{3}{2} \Omega$$

$$\therefore \text{Current through battery} = \frac{6 \times 2}{3} = 4 \text{ A}$$

$$i_2 = \frac{4}{8} \times 2 = 1 \text{ A}$$

$$\therefore \Delta V \text{ across e-f} = \frac{i_2}{2} \times R = \frac{1}{2} \times 2 = 1 \text{ V}$$

56. A soap bubble is blown to a diameter of 7 cm. 36960 erg of work is done in blowing it further. If surface tension of soap solution is 40 dyne/cm then the new radius is _____ cm. Take : $\left(\pi = \frac{22}{7} \right)$.

Ans. (7)

Sol. $\omega = \Delta U = S \Delta A$

$$36960 \text{ erg} = \frac{40 \text{ dyne}}{\text{cm}} 8\pi \left[(r)^2 - \left(\frac{7}{2} \right)^2 \right] \text{ cm}^2$$

$$r = 7 \text{ cm}$$

57. Two wavelengths λ_1 and λ_2 are used in Young's double slit experiment $\lambda_1 = 450 \text{ nm}$ and $\lambda_2 = 650 \text{ nm}$. The minimum order of fringe produced by λ_2 which overlaps with the fringe produced by λ_1 is n. The value of n is _____.

Ans. (9)

Sol. $n_2 \lambda_2 = n_1 \lambda_1$

$$\frac{n_2}{n_1} = \frac{\lambda_1}{\lambda_2} = \frac{450}{650} = \frac{9}{13}$$

$$n_2 = 9$$

58. An elastic spring under tension of 3 N has a length a. Its length is b under tension 2 N. For its length $(3a - 2b)$, the value of tension will be _____ N.

Ans. (5)

Sol. $3 = K(a - \ell)$

$$2 = K(b - \ell)$$

$$T = K(3a - 2b - \ell)$$

$$T = K(3(a - \ell) - 2(b - \ell))$$

$$= K \left[3 \left(\frac{3}{K} \right) - 2 \left(\frac{2}{K} \right) \right]$$

$$= 9 - 4$$

$$= 5 \text{ N}$$

59. Two forces \vec{F}_1 and \vec{F}_2 are acting on a body. One force has magnitude thrice that of the other force and the resultant of the two forces is equal to the force of larger magnitude. The angle between \vec{F}_1 and \vec{F}_2 is $\cos^{-1}\left(\frac{1}{n}\right)$. The value of $|n|$ is ____.

Ans. (6)

Sol. $|\vec{F}_1| = F$

$$|\vec{F}_R| = |\vec{F}_2| = 3F$$

$$F_R^2 = F_1^2 + F_2^2 + 2F_1F_2 \cos \theta$$

$$9F^2 = F^2 + 9F^2 + 6F^2 \cos \theta$$

$$\cos \theta = -\frac{1}{6}$$

$$\theta = \cos^{-1}\left(\frac{1}{-6}\right)$$

$$n = -6$$

$$|n| = 6$$

60. A solid sphere and a hollow cylinder roll up without slipping on same inclined plane with same initial speed v . The sphere and the cylinder reaches upto maximum heights h_1 and h_2 , respectively, above the initial level. The ratio $h_1 : h_2$ is $\frac{n}{10}$. The value of n is ____.

Ans. (7)

Sol Gain in P.E. = Loss in K.E.

$$mgh = \frac{1}{2}mv^2 \left(1 + \frac{K^2}{R^2}\right)$$

$$h \propto 1 + \frac{K^2}{R^2}$$

$$\frac{h_1}{h_2} = \frac{1 + \frac{2}{5}}{1 + 1} = \frac{7}{5 \times 2} = \frac{7}{10}$$

$$n = 7$$

CHEMISTRY

TEST PAPER WITH SOLUTION

SECTION-A

61. What pressure (bar) of H_2 would be required to make emf of hydrogen electrode zero in pure water at $25^\circ C$?

- (1) 10^{-14} (2) 10^{-7} (3) 1 (4) 0.5

NTA Ans. (3)

Sol. $2e^- + 2H^+(aq) \rightarrow H_2(g)$

$$E = E^\circ - \frac{0.059}{n} \log \frac{P_{H_2}}{[H^+]^2}$$

$$0 = 0 - \frac{0.059}{2} \log \frac{P_{H_2}}{(10^{-7})^2}$$

$$\log \frac{P_{H_2}}{(10^{-7})^2} = 0$$

$$\frac{P_{H_2}}{10^{-14}} = 1$$

$$P_{H_2} = 10^{-14} \text{ bar}$$

62. The correct sequence of ligands in the order of decreasing field strength is :

- (1) $CO > H_2O > F^- > S^{2-}$
 (2) $^-OH > F^- > NH_3 > CN^-$
 (3) $NCS^- > EDTA^{4-} > CN^- > CO$
 (4) $S^{2-} > ^-OH > EDTA^{4-} > CO$

Ans. (1)

Sol. According to spectrochemical series ligand field strength is $CO > H_2O > F^- > S^{2-}$

63. Match List -I with List II:

List - I Mechanism steps		List - II Effect	
(A)		(I)	- E effect
(B)		(II)	- R effect
(C)		(III)	+ E effect
(D)		(IV)	+ R effect

Choose the **correct** answer from the options given below :

- (1) (A) - (IV), (B) - (III), (C) - (I), (D) - (II)
 (2) (A) - (III), (B) - (I), (C) - (II), (D) - (IV)
 (3) (A) - (II), (B) - (IV), (C) - (III), (D) - (I)
 (4) (A) - (I), (B) - (II), (C) - (IV), (D) - (III)

Ans. (1)

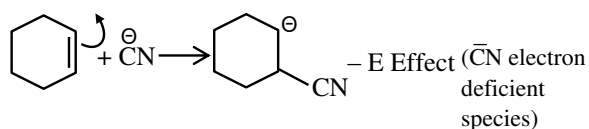
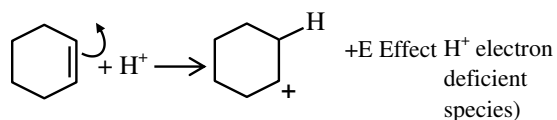
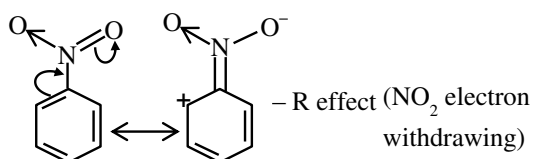
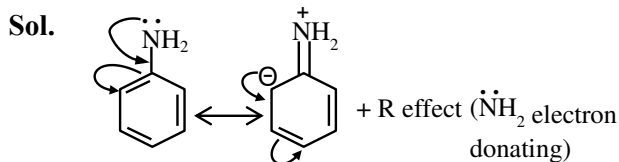

64. What will be the decreasing order of basic strength of the following conjugate bases ?



- (1) $\text{Cl}^- > \text{OH}^- > \text{RO}^- > \text{CH}_3\text{COO}^-$
- (2) $\text{RO}^- > \text{OH}^- > \text{CH}_3\text{COO}^- > \text{Cl}^-$
- (3) $\text{OH}^- > \text{RO}^- > \text{CH}_3\text{COO}^- > \text{Cl}^-$
- (4) $\text{Cl}^- > \text{RO}^- > \text{OH}^- > \text{CH}_3\text{COO}^-$

Ans. (2)

Sol. Strong acid have weak conjugate base

Acidic strength :



Conjugate base strength :



65. In the precipitation of the iron group (III) in qualitative analysis, ammonium chloride is added before adding ammonium hydroxide to :

- (1) prevent interference by phosphate ions
- (2) decrease concentration of OH^- ions
- (3) increase concentration of Cl^- ions
- (4) increase concentration of NH_4^+ ions

Ans. (2)

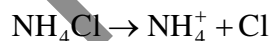

Due to common ion effect of NH_4^+ ,

$[\text{OH}^-]$ decreases in such extent that only group-III cation can be precipitated, due to their very low K_{sp} in the range of 10^{-38} .

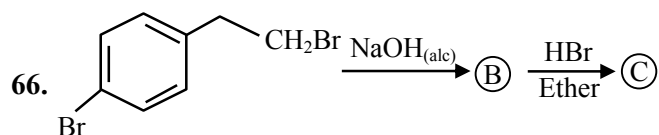

Identify (B) and (C) and how are (A) and (C) related ?

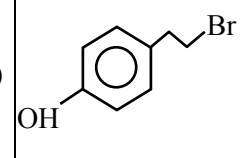
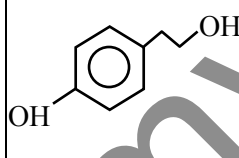
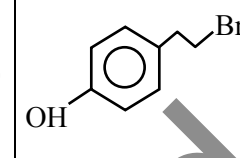
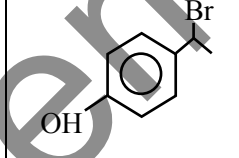
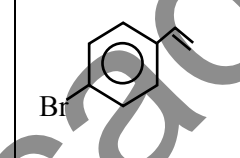
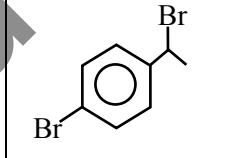
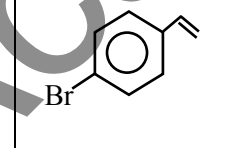
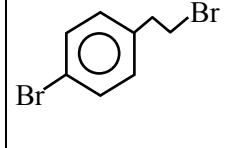
	(B)	(C)	
(1)			functional group isomers
(2)			Derivative
(3)			position isomers
(4)			chain isomers

Ans. (3)

Sol.

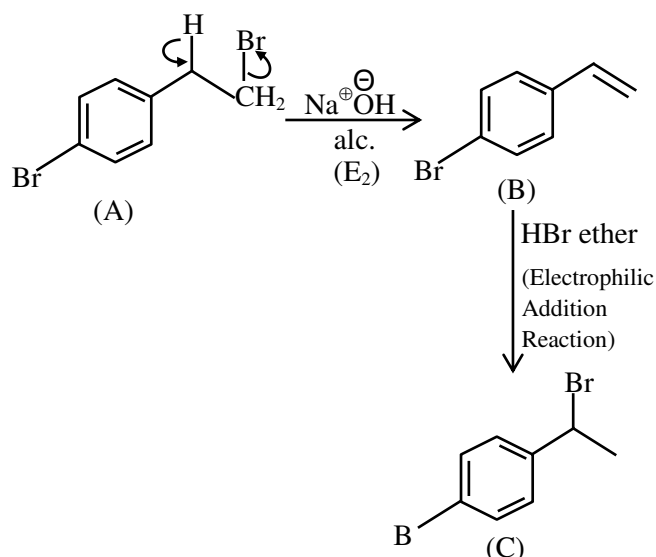

A and C are position isomer.

67. One of the commonly used electrode is calomel electrode. Under which of the following categories calomel electrode comes ?

- (1) Metal – Insoluble Salt – Anion electrodes
- (2) Oxidation – Reduction electrodes
- (3) Gas – Ion electrodes
- (4) Metal ion – Metal electrodes

Ans. (1)

Sol. Theory based

68. Number of complexes from the following with even number of unpaired "d" electrons is ____.

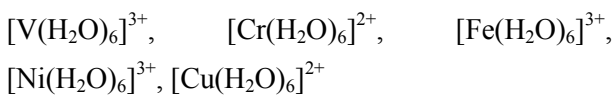

[Given atomic numbers : V = 23, Cr = 24, Fe = 26,
 Ni = 28, Cu = 29]

- (1) 2
- (2) 4
- (3) 5
- (4) 1

Ans. (1)

Sol. $[\text{V}(\text{H}_2\text{O})_6]^{3+} \rightarrow d^2 sp^3$



$\text{V}^{3+} :- [\text{Ar}]3d^2$, n = 2 (even number of unpaired e^-)

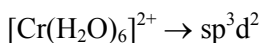

$\text{Cr}^{2+} :- [\text{Ar}]3d^4$, n = 4 (even number of unpaired e^-)

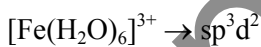
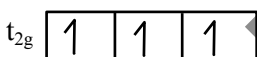
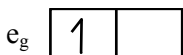

n = 5 (odd number of unpaired e^-)

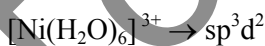

$\text{Ni}^{3+} :- [\text{Ar}]3d^7$, n = 3 (odd number of unpaired e^-)

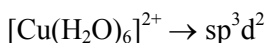

n = 1 (odd number of unpaired e^-)

69. Which one of the following molecules has maximum dipole moment ?

- (1) NF_3
- (2) CH_4
- (3) NH_3
- (4) PF_5

Ans. (3)

Sol. CH_4 & PF_5 , $\mu_{\text{net}} = 0$ (non polar)

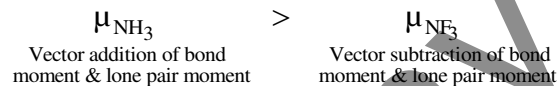

70. Number of molecules/ions from the following in which the central atom is involved in sp^3 hybridization is ____.

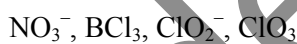

- (1) 2
- (2) 4
- (3) 3
- (4) 1

Ans. (1)

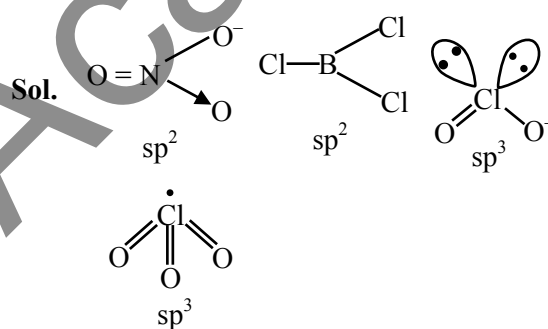

71. Which among the following is **incorrect** statement?

- (1) Electromeric effect dominates over inductive effect
- (2) The electromeric effect is, temporary effect
- (3) The organic compound shows electromeric effect in the presence of the reagent only
- (4) Hydrogen ion (H^+) shows negative electromeric effect

Ans. (4)

Sol. Hydrogen ion (H^+) shows positive electromeric effect.

72. Given below are two statements :

Statement I : Acidity of α -hydrogens of aldehydes and ketones is responsible for Aldol reaction.

Statement II : Reaction between benzaldehyde and ethanal will NOT give Cross - Aldol product.

In the light of above statements, choose the **most appropriate** answer from the options given below.

- (1) Both **Statement I** and **Statement II** are correct.
- (2) Both **Statement I** and **Statement II** are incorrect.
- (3) **Statement I** is incorrect but **Statement II** is correct.
- (4) **Statement I** is correct but **Statement II** is incorrect.

Ans. (4)

Sol. Aldehyde and ketones having acidic α -hydrogen show aldol reaction

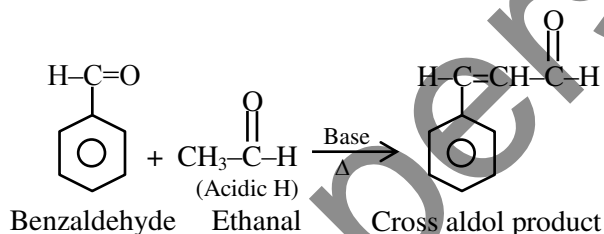

73. Which of the following nitrogen containing compound does not give Lassaigne's test ?

- (1) Phenyl hydrazine
- (2) Glycine
- (3) Urea
- (4) Hydrazine

Ans. (4)

Sol. Hydrazine ($\text{NH}_2\text{-NH}_2$) have no carbon so does not show Lassaigne's test.

74. Which of the following is the correct structure of L-Glucose ?

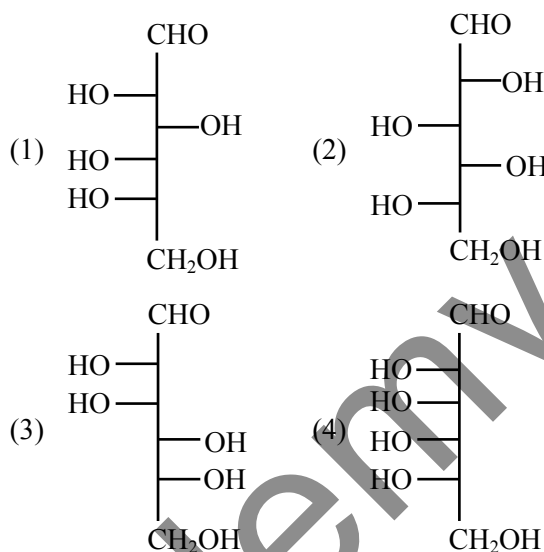

Ans. (1)

Sol. Structure of L-Glucose is

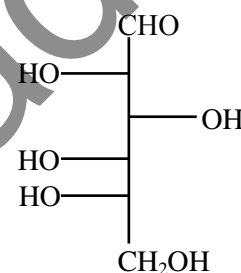

75. The element which shows only one oxidation state other than its elemental form is :

- (1) Cobalt
- (2) Scandium
- (3) Titanium
- (4) Nickel

Ans. (2)

Sol. Co, Ti, Ni can show +2, +3 and +4 oxidation state, But 'Sc' only shows +3 stable oxidation state.

76. Identify the product in the following reaction :

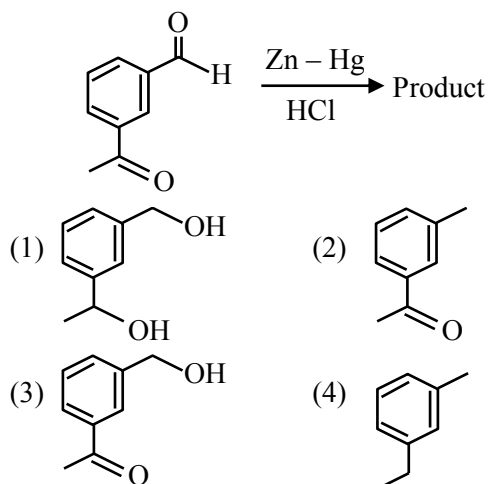

Ans. (4)

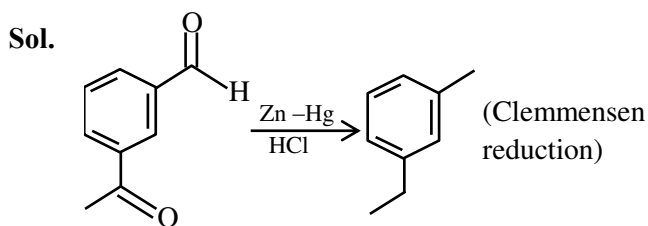

77. Number of elements from the following that CANNOT form compounds with valencies which match with their respective group valencies is _____.

B, C, N, S, O, F, P, Al, Si

- (1) 7 (2) 5 (3) 6 (4) 3

Ans. (4)

Sol. N, O, F can't extend their valencies upto their group number due to the non-availability of vacant 2d like orbital.

78. The Molarity (M) of an aqueous solution containing 5.85 g of NaCl in 500 mL water is :

(Given : Molar Mass Na : 23 and Cl : 35.5 gmol^{-1})

- (1) 2 (2) 0.2
(3) 2 (4) 4

Ans. (2)

Sol. $M = \frac{n_{\text{NaCl}}}{V_{\text{sol}} \text{ (in L)}}$

$$M = \frac{5.85}{0.5} = 0.2\text{M}$$

79. Identify the correct set of reagents or reaction conditions 'X' and 'Y' in the following set of transformation.

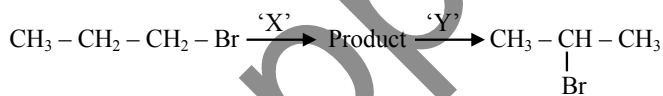

- (1) X = conc.alc. NaOH, 80°C, Y = Br₂/CHCl₃
(2) X = dil.aq. NaOH, 20°C, Y = HBr/acetic acid
(3) X = conc.alc. NaOH, 80°C, Y = HBr/acetic acid
(4) X = dil.aq. NaOH, 20°C, Y = Br₂/CHCl₃

Ans. (3)

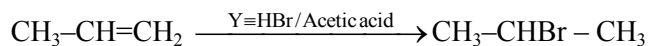
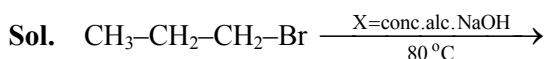

80. The correct order of first ionization enthalpy values of the following elements is :

- (A) O (B) N
(C) Be (D) F
(E) B

Choose the correct answer from the options given below :

- (1) B < D < C < E < A (2) E < C < A < B < D
(3) C < E < A < B < D (4) A < B < D < C < E

Ans. (2)

Sol. Correct order of Ist IE

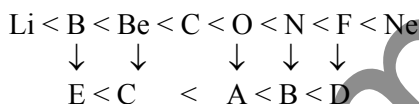

SECTION-B

81. The enthalpy of formation of ethane (C₂H₆) from ethylene by addition of hydrogen where the bond-energies of C-H, C-C, H-H are 414 kJ, 347 kJ, 615 kJ and 435 kJ respectively is - _____ kJ.

Ans. (125)

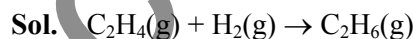

$$\Delta H = \text{BE}(\text{C} = \text{C}) + 4\text{BE}(\text{C} - \text{H}) + \text{BE}(\text{H} - \text{H}) - \text{BE}(\text{C} - \text{C}) - 6\text{BE}(\text{C} - \text{H})$$

$$\Delta H = \text{BE}(\text{C} = \text{C}) + \text{BE}(\text{H} - \text{H}) - \text{BE}(\text{C} - \text{C}) - 2\text{BE}(\text{C} - \text{H})$$

$$= 615 + 435 - 347 - 2 \times 414$$

$$= -125 \text{ kJ}$$

82. The number of correct reaction(s) among the following is _____.

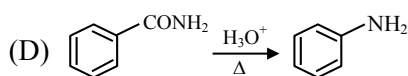
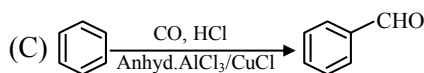
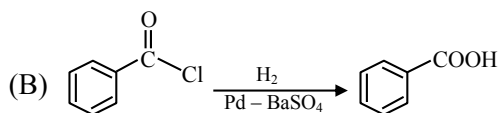
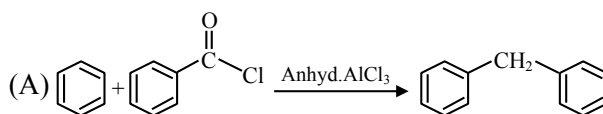

Ans. (1)

87. Consider the following transformation involving first order elementary reaction in each step at constant temperature as shown below.

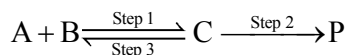

Some details of the above reaction are listed below.

Step	Rate constant (sec ⁻¹)	Activation energy (kJ mol ⁻¹)
1	k ₁	300
2	k ₂	200
3	k ₃	E _{a3}

If the overall rate constant of the above transformation (k) is given as $k = \frac{k_1 k_2}{k_3}$ and the

overall activation energy (E_a) is 400 kJ mol⁻¹, then the value of E_{a3} is _____ kJ mol⁻¹ (nearest integer)

Ans. (100)

Sol. $K = \frac{K_1 K_2}{K_3}$

$$Ae^{\frac{-E_a}{RT}} = \frac{A_1 e^{\frac{-E_{a1}}{RT}} A_2 e^{\frac{-E_{a2}}{RT}}}{A_3 e^{\frac{-E_{a3}}{RT}}}$$

$$Ae^{\frac{-E_a}{RT}} = \frac{A_1 A_2}{A_3} e^{\frac{-(E_{a1} + E_{a2} - E_{a3})}{RT}}$$

$$E_a = E_{a1} + E_{a2} - E_{a3}$$

$$400 = 300 + 200 - E_{a3}$$

$$E_{a3} = 100 \text{ kJ/mole}$$

88. 2.5 g of a non-volatile, non-electrolyte is dissolved in 100 g of water at 25°C. The solution showed a boiling point elevation by 2°C. Assuming the solute concentration is negligible with respect to the solvent concentration, the vapour pressure of the resulting aqueous solution is _____ mm of Hg (nearest integer)

[Given : Molal boiling point elevation constant of water (K_b) = 0.52 K. kg mol⁻¹,

1 atm pressure = 760 mm of Hg, molar mass of water = 18 g mol⁻¹]

Ans. (707)

Sol. $2 = 0.52 \times m$

$$m = \frac{2}{0.52}$$

According to question, solution is much diluted

$$\text{so } \frac{\Delta P}{P^\circ} = \frac{n_{\text{solute}}}{n_{\text{solvent}}}$$

$$\frac{\Delta P}{P^\circ} = \frac{m}{1000} \times M_{\text{solvent}}$$

$$\Delta P = P^\circ \times \frac{m}{1000} \times M_{\text{solvent}}$$

$$= 760 \times \frac{2}{1000} \times 18 = 52.615$$

$$P_5 = 760 - 52.615 = 707.385 \text{ mm of Hg}$$

89. The number of different chain isomers for C₇H₁₆ is _____.

Ans. (9)

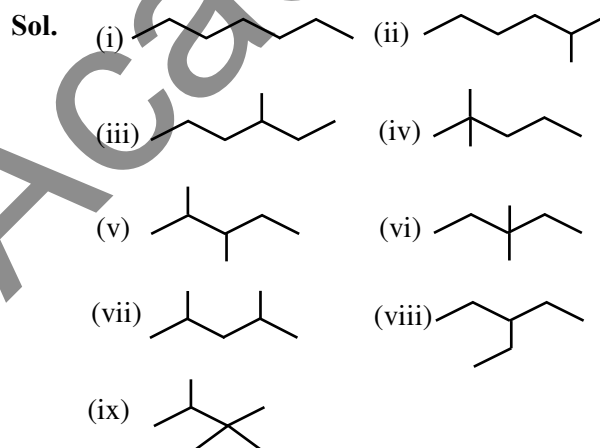

90. Number of molecules/species from the following having one unpaired electron is _____.



Ans. (2)

Sol. According to M.O.T.

$$O_2 \rightarrow \text{no. of unpaired electrons} = 2$$

$$O_2^{-1} \rightarrow \text{no. of unpaired electron} = 1$$

$$NO \rightarrow \text{no. of unpaired electron} = 1$$

$$CN^{-1} \rightarrow \text{no. of unpaired electron} = 0$$

$$O_2^{2-} \rightarrow \text{no. of unpaired electron} = 0$$

FINAL JEE–MAIN EXAMINATION – APRIL, 2024

(Held On Thursday 04th April, 2024)

TIME : 3 : 00 PM to 6 : 00 PM

MATHEMATICS

TEST PAPER WITH SOLUTION

SECTION-A

1. If the function $f(x) = \begin{cases} \frac{72^x - 9^x - 8^x + 1}{\sqrt{2} - \sqrt{1 + \cos x}}, & x \neq 0 \\ a \log_e 2 \log_e 3, & x = 0 \end{cases}$

is continuous at $x = 0$, then the value of a^2 is equal to

- (1) 968 (2) 1152
(3) 746 (4) 1250

Ans. (2)

Sol. $\lim_{x \rightarrow 0} f(x) = a \ln 2 \ln 3$

$$\lim_{x \rightarrow 0} \frac{72^x - 9^x - 8^x + 1}{\sqrt{2} - \sqrt{1 + \cos x}} = \lim_{x \rightarrow 0} \frac{(8^x - 1)(9^x - 1)}{\sqrt{2} - \sqrt{1 + \cos x}}$$

$$\lim_{x \rightarrow 0} \left(\frac{8^x - 1}{x} \right) \left(\frac{9^x - 1}{x} \right) \left(\frac{x^2}{1 - \cos x} \right) (\sqrt{2} + \sqrt{1 + \cos x})$$

$$\therefore \ln 8 \times \ln 9 \times 2 \times 2\sqrt{2} = 24\sqrt{2} \ln 2 \ln 3$$

$$\therefore a = 24\sqrt{2}, a^2 = 576 \times 2 = 1152$$

2. If $\lambda > 0$, let θ be the angle between the vectors $\vec{a} = \hat{i} + \lambda\hat{j} - 3\hat{k}$ and $\vec{b} = 3\hat{i} - \hat{j} + 2\hat{k}$. If the vectors $\vec{a} + \vec{b}$ and $\vec{a} - \vec{b}$ are mutually perpendicular, then the value of $(14 \cos \theta)^2$ is equal to

- (1) 25 (2) 20
(3) 50 (4) 40

Ans. (1)

Sol. $(\vec{a} + \vec{b}) \cdot (\vec{a} - \vec{b}) = 0, \lambda > 0$

$$|\vec{a}|^2 - |\vec{b}|^2 = 0 \rightarrow 1 + \lambda^2 + 9 = 9 + 1 + 4$$

$$\therefore \lambda = 2, \cos \theta = \frac{\vec{a} \cdot \vec{b}}{|\vec{a}| |\vec{b}|} = \frac{3 - \lambda - 6}{\sqrt{14} \cdot \sqrt{14}}$$

$$14 \cos \theta = 3 - 8 = -5$$

$$\therefore (14 \cos \theta)^2 = 25$$

3. Let C be a circle with radius $\sqrt{10}$ units and centre at the origin. Let the line $x + y = 2$ intersects the circle C at the points P and Q . Let MN be a chord of C of length 2 unit and slope -1 . Then, a distance (in units) between the chord PQ and the chord MN is

- (1) $2 - \sqrt{3}$ (2) $3 - \sqrt{2}$
(3) $\sqrt{2} - 1$ (4) $\sqrt{2} + 1$

Ans. (2)

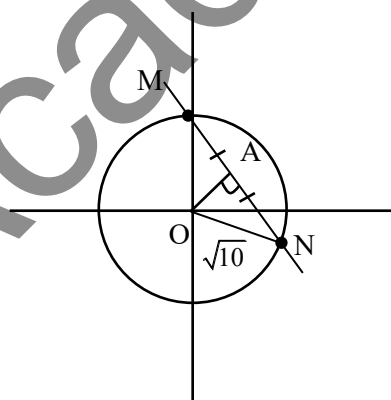

$$C : x^2 + y^2 = 10$$

$$AN = \frac{MN}{2} = 1$$

$$\therefore \text{In } \Delta OAN \rightarrow (ON)^2 = (OA)^2 + (AN)^2$$

$$10 = (OA)^2 + 1 \rightarrow OA = 3$$

Perpendicular distance of center from

$$PQ = \frac{|0 + 0 - 2|}{\sqrt{2}} = \sqrt{2}$$

Perpendicular distance between MN and

$$PQ = OA + \sqrt{2} \text{ or } |OA - \sqrt{2}|$$

$$= 3 + \sqrt{2} \text{ or } 3 - \sqrt{2}$$

4. Let a relation R on $\mathbb{N} \times \mathbb{N}$ be defined as :
 $(x_1, y_1) R(x_2, y_2)$ if and only if $x_1 \leq x_2$ or $y_1 \leq y_2$

Consider the two statements :

- (I) R is reflexive but not symmetric.
 (II) R is transitive

Then which one of the following is true ?

- (1) Only (II) is correct.
 (2) Only (I) is correct.
 (3) Both (I) and (II) are correct.
 (4) Neither (I) nor (II) is correct.

Ans. (2)

Sol. All $((x_1, y_1), (x_1, y_1))$ are in R where

$x_1, y_1 \in \mathbb{N} \therefore$ R is reflexive

$((1,1), (2,3)) \in R$ but $((2,3), (1,1)) \notin R$

\therefore R is not symmetric

$((2,4), (3,3)) \in R$ and $((3,3), (1,3)) \in R$ but $((2,4), (1,3)) \notin R$

\therefore R is not transitive

5. Let three real numbers a,b,c be in arithmetic progression and $a + 1, b, c + 3$ be in geometric progression. If $a > 10$ and the arithmetic mean of a,b and c is 8, then the cube of the geometric mean of a,b and c is

- (1) 120 (2) 312
 (3) 316 (4) 128

Ans. (1)

Sol. $2b = a + c, b^2 = (a + 1)(c + 3),$

$$\frac{a + b + c}{3} = 8 \rightarrow b = 8, a + c = 16$$

$$64 = (a + 1)(19 - a) = 19 + 18a - a^2$$

$$a^2 - 18a - 45 = 0 \rightarrow (a - 15)(a + 3) = 0, (a > 10)$$

$$a = 15, c = 1, b = 8$$

$$((abc)^{1/3})^3 = abc = 120$$

6. Let $A = \begin{bmatrix} 1 & 2 \\ 0 & 1 \end{bmatrix}$ and $B = I + \text{adj}(A) + (\text{adj} A)^2 + \dots + (\text{adj} A)^{10}$. Then, the sum of all the elements of the matrix B is :

- (1) -110 (2) 22
 (3) -88 (4) -124

Ans. (3)

Sol. $\text{Adj}(A) = \begin{bmatrix} 1 & -2 \\ 0 & 1 \end{bmatrix}$

$$(\text{Adj}A)^2 = \begin{bmatrix} 1 & -4 \\ 0 & 1 \end{bmatrix}$$

$$\vdots$$

$$(\text{Adj}A)^{10} = \begin{bmatrix} 1 & -20 \\ 0 & 1 \end{bmatrix}$$

$$B = \begin{bmatrix} 1 & 0 \\ 0 & 1 \end{bmatrix} + \begin{bmatrix} 1 & -2 \\ 0 & 1 \end{bmatrix} + \begin{bmatrix} 1 & -4 \\ 0 & 1 \end{bmatrix} + \dots + \begin{bmatrix} 1 & -20 \\ 0 & 1 \end{bmatrix}$$

$$B = \begin{bmatrix} 11 & -110 \\ 0 & 11 \end{bmatrix} \Rightarrow \text{sum of elements of B} = -88$$

7. The value of $\frac{1 \times 2^2 + 2 \times 3^2 + \dots + 100 \times (101)^2}{1^2 \times 2 + 2^2 \times 3 + \dots + 100^2 \times 101}$ is

- (1) $\frac{306}{305}$ (2) $\frac{305}{301}$
 (3) $\frac{32}{31}$ (4) $\frac{31}{30}$

Ans. (2)

Sol. $\frac{1 \times 2^2 + 2 \times 3^2 + \dots + 100 \times (101)^2}{1^2 \times 2 + 2^2 \times 3 + \dots + 100^2 \times 101} = \frac{\sum_{r=1}^{100} r(r+1)^2}{\sum_{r=1}^{100} r^2(r+1)}$

$$= \frac{\sum_{r=1}^{100} (r^3 + 2r^2 + r)}{\sum_{r=1}^{100} (r^3 + r^2)} = \frac{\left(\frac{n(n+1)^2}{2}\right) + \frac{2 \cdot n(n+1)(2n+1)}{6} + \frac{n(n+1)}{2}}{\left(\frac{n(n+1)}{2}\right)^2 + \frac{n(n+1)(2n+1)}{6}}$$

$$= \frac{\frac{n(n+1)}{2} \left[\frac{n(n+1)}{2} + \frac{2}{3} \cdot (2n+1) + 1 \right]}{\frac{n(n+1)}{2} \left[\frac{n(n+1)}{2} + \frac{(2n+1)}{3} \right]}$$

$$= \frac{100(101)}{2} + \frac{2}{3}(201) + 1 = \frac{5185}{2} = \frac{305}{301}$$

11. If the value of the integral $\int_{-1}^1 \frac{\cos \alpha x}{1+3^x} dx$ is $\frac{2}{\pi}$.

Then, a value of α is

- (1) $\frac{\pi}{6}$ (2) $\frac{\pi}{2}$
 (3) $\frac{\pi}{3}$ (4) $\frac{\pi}{4}$

Ans. (2)

Sol. Let $I = \int_{-1}^{+1} \frac{\cos \alpha x}{1+3^x} dx$... (I)

$$I = \int_{-1}^{+1} \frac{\cos \alpha x}{1+3^{-x}} dx$$

$$\left(\text{using } \int_a^b f(x) dx = \int_a^b f(a+b-x) dx \right) \dots \text{(II)}$$

Add (1) and (II)

$$2I = \int_{-1}^{+1} \cos(\alpha x) dx = 2 \int_0^1 \cos(\alpha x) dx$$

$$I = \frac{\sin \alpha}{\alpha} = \frac{2}{\pi} \text{ (given)}$$

$$\therefore \alpha = \frac{\pi}{2}$$

12. Let $f(x) = 3\sqrt{x-2} + \sqrt{4-x}$ be a real valued function. If α and β are respectively the minimum and the maximum values of f , then $\alpha^2 + 2\beta^2$ is equal to

- (1) 44 (2) 42
 (3) 24 (4) 38

Ans. (2)

Sol. $f(x) = 3\sqrt{x-2} + \sqrt{4-x}$

$$x-2 \geq 0 \text{ \& } 4-x \geq 0$$

$$\therefore x \in [2, 4]$$

$$\text{Let } x = 2\sin^2\theta + 4\cos^2\theta$$

$$\therefore f(x) = 3\sqrt{2}|\cos\theta| + \sqrt{2}|\sin\theta|$$

$$\therefore \sqrt{2} \leq 3\sqrt{2}|\cos\theta| + \sqrt{2}|\sin\theta| \leq \sqrt{9 \times 2 + 2}$$

$$\sqrt{2} \leq 3\sqrt{2}|\cos\theta| + \sqrt{2}|\sin\theta| \leq \sqrt{20}$$

$$\therefore \alpha = \sqrt{2} \quad \beta = \sqrt{20}$$

$$\alpha^2 + 2\beta^2 = 2 + 40 = 42$$

13. If the coefficients of x^4 , x^5 and x^6 in the expansion of $(1+x)^n$ are in the arithmetic progression, then the maximum value of n is :

- (1) 14 (2) 21
 (3) 28 (4) 7

Ans. (1)

Sol. Coeff. of $x^4 = {}^nC_4$

$$\text{Coeff. of } x^5 = {}^nC_5$$

$$\text{Coeff. of } x^6 = {}^nC_6$$

$${}^nC_4, {}^nC_5, {}^nC_6 \dots \text{ AP}$$

$$2 \cdot {}^nC_5 = {}^nC_4 + {}^nC_6$$

$$2 = \frac{{}^nC_4}{{}^nC_5} + \frac{{}^nC_6}{{}^nC_5} \left\{ \frac{{}^nC_r}{{}^nC_{r-1}} = \frac{n-r+1}{r} \right\}$$

$$2 = \frac{5}{n-4} + \frac{n-5}{6}$$

$$12(n-4) = 30 + n^2 - 9n + 20$$

$$n^2 - 21n + 98 = 0$$

$$(n-14)(n-7) = 0$$

$$n_{\max} = 14 \quad n_{\min} = 7$$

14. Consider a hyperbola H having centre at the origin and foci and the x-axis. Let C_1 be the circle touching the hyperbola H and having the centre at the origin. Let C_2 be the circle touching the hyperbola H at its vertex and having the centre at one of its foci. If areas (in sq. units) of C_1 and C_2 are 36π and 4π , respectively, then the length (in units) of latus rectum of H is

- (1) $\frac{28}{3}$ (2) $\frac{14}{3}$
 (3) $\frac{10}{3}$ (4) $\frac{11}{3}$

Ans. (1)

Sol. Let $H: \frac{x^2}{a^2} - \frac{y^2}{b^2} = 1$ ($b^2 = a^2(e^2 - 1)$)

\therefore eqⁿ of $C_1 = x^2 + y^2 = a^2$

Ar. = 36π

$\pi a^2 = 36\pi$

$a = 6$

Now radius of C_2 can be $a(e - 1)$ or $a(e + 1)$

for $r = a(e - 1)$ for $r = a(e + 1)$

Ar. = 4π

$\pi r^2 = 4\pi$

$\pi a^2(e - 1)^2 = 4\pi$

$a^2(e + 1)^2 = 4$

$36\pi(e - 1)^2 = 4\pi$

$36(e + 1)^2 = 4$

$e - 1 = \frac{1}{3}$

$e + 1 = \frac{1}{3}$

$e = \frac{4}{3}$

$\frac{2}{3}$

Not possible

$\therefore b^2 = 36\left(\frac{16}{9} - 1\right) = 28$

$\therefore LR = \frac{2b^2}{a} = \frac{2 \times 28}{6} = \frac{28}{3}$

15. If the mean of the following probability distribution of a random variable X;

X	0	2	4	6	8
P(X)	a	2a	a + b	2b	3b

is $\frac{46}{9}$, then the variance of the distribution is

(1) $\frac{581}{81}$

(2) $\frac{566}{81}$

(3) $\frac{173}{27}$

(4) $\frac{151}{27}$

Ans. (2)

Sol. $\sum P_i = 1$

$a + 2a + a + b + 2b + 3b = 1$

$4a + 6b = 1$ (I)

$E(x) = \text{mean} = \frac{46}{9}$

$\sum P_i X_i = \frac{46}{9} \Rightarrow 4a + 4a + 4b + 12b + 24b = \frac{46}{9}$

$8a + 40b = \frac{46}{9}$

$4a + 20b = \frac{23}{9}$ (II)

Subtract (I) from (II) we get

$b = \frac{1}{9}$ & $a = \frac{1}{12}$

Variance = $E(x_i^2) - E(x_i)^2$

$E(x_i^2) = 0^2 \times 9^2 + 2^2 \times 2a + 4^2(a + b) + 6^2(2b) + 8^2(3b)$
 $= 24a + 280b$

Put $a = \frac{1}{12}$ $b = \frac{1}{9}$

$E(x_i^2) = 2 + \frac{280}{9} = \frac{298}{9}$

$\therefore \sigma^2 = E(x_i^2) - E(x_i)^2$

$= \frac{298}{9} - \left(\frac{46}{9}\right)^2$

$\sigma^2 = \frac{298}{9} - \frac{2116}{81}$

$= \frac{566}{81}$

16. Let PQ be a chord of the parabola $y^2 = 12x$ and the midpoint of PQ be at (4,1). Then, which of the following point lies on the line passing through the points P and Q ?

(1) (3, -3)

(2) $\left(\frac{3}{2}, -16\right)$

(3) (2, -9)

(4) $\left(\frac{1}{2}, -20\right)$

Ans. (4)

Sol.

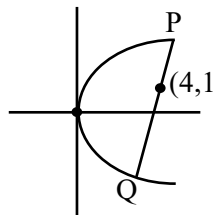

$T = S_1$

$y - 6(x + 4)$

$= 1 - 48$

$6x - y = 23$

Option 4 $\left(\frac{1}{2}, -20\right)$ will satisfy

Sol. $\vec{d} = \lambda(\vec{b} + \vec{c})$

$$\vec{a} \cdot \vec{d} = \lambda(\vec{b} \cdot \vec{a} + \vec{c} \cdot \vec{a})$$

$$1 = \lambda(1 + x + 5)$$

$$1 = \lambda(x + 6) \quad \dots(1)$$

$$|\vec{d}| = 1 \quad \boxed{\frac{1}{\lambda} = x + 6}$$

$$|\lambda(\vec{b} + \vec{c})| = 1$$

$$\left| \lambda((x+2)\hat{i} + 6\hat{j} - 2\hat{k}) \right| = 1$$

$$\lambda^2((x+2)^2 + 6^2 + 2^2) = 1$$

$$x^2 + 4x + 4 + 36 + 4 = (x+6)^2$$

$$x^2 + 4x + 44 = x^2 + 12x + 36$$

$$8x = 8, x = 1$$

$$\begin{vmatrix} 1 & 1 & 1 \\ 2 & 4 & -5 \\ x & 2 & 3 \end{vmatrix} = (\vec{a} \times \vec{b}) \cdot \vec{c}$$

$$\begin{vmatrix} 0 & 0 & 1 \\ -2 & 9 & -4 \\ x-2 & -1 & 3 \end{vmatrix} = 2 - 9(x-2)$$

$$= 20 - 9x$$

$$\text{at } x = 1$$

$$20 - 9 = 11$$

Option 4 is correct

20. Let P the point of intersection of the lines

$$\frac{x-2}{1} = \frac{y-4}{5} = \frac{z-2}{1} \quad \text{and} \quad \frac{x-3}{2} = \frac{y-2}{3} = \frac{z-3}{2}$$

Then, the shortest distance of P from the line

$$4x = 2y = z \text{ is}$$

(1) $\frac{5\sqrt{14}}{7}$ (2) $\frac{\sqrt{14}}{7}$

(3) $\frac{3\sqrt{14}}{7}$ (4) $\frac{6\sqrt{14}}{7}$

Ans. (3)

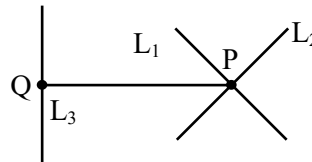

$$L_1 \equiv \frac{x-2}{1} = \frac{y-4}{5} = \frac{z-2}{1} = \lambda$$

$$P(\lambda+2, 5\lambda+4, \lambda+2)$$

$$L_2 \equiv \frac{x-3}{2} = \frac{y-2}{3} = \frac{z-3}{2} = \mu$$

$$P(2\mu+3, 3\mu+2, 2\mu+3)$$

$$\lambda+2 = 2\mu+3 \quad 3\mu+2 = 5\lambda+4$$

$$\lambda = 2\mu+1 \quad 3\mu = 5\lambda+2$$

$$3\mu = 5(2\mu+1) + 2$$

$$3\mu = 10\mu + 7$$

$$\mu = -1 \quad \lambda = -1$$

Both satisfies (P)

$$P(1, -1, 1)$$

$$L_3 \equiv \frac{x}{1/4} = \frac{y}{1/2} = \frac{z}{1}$$

$$L_3 = \frac{x}{1} = \frac{y}{2} = \frac{z}{4} = k$$

Coordinates of Q(k, 2k, 4k)

$$\text{DR's of PQ} = \langle k-1, 2k+1, 4k-1 \rangle$$

PQ \perp to L₃

$$(k-1) + 2(2k+1) + 4(4k-1) = 0$$

$$k-1 + 4k+2 + 16k-4 = 0$$

$$k = \frac{1}{7}$$

$$Q\left(\frac{1}{7}, \frac{2}{7}, \frac{4}{7}\right)$$

$$PQ = \sqrt{\left(1 - \frac{1}{7}\right)^2 + \left(-1 - \frac{2}{7}\right)^2 + \left(1 - \frac{4}{7}\right)^2}$$

$$= \sqrt{\frac{36}{49} + \frac{81}{49} + \frac{9}{49}} = \frac{\sqrt{126}}{7}$$

$$PQ = \frac{3\sqrt{14}}{7}$$

Option-3 will satisfy

SECTION-B

21. Let $S = \{\sin^2 2\theta : (\sin^4 \theta + \cos^4 \theta)x^2 + (\sin 2\theta)x + (\sin^6 \theta + \cos^6 \theta) = 0 \text{ has real roots}\}$. If α and β be the smallest and largest elements of the set S , respectively, then $3((\alpha - 2)^2 + (\beta - 1)^2)$ equals.....

Ans. (4)

Sol. $D = (\sin 2\theta)^2 - 4\left(1 - \frac{\sin^2 2\theta}{2}\right)\left(1 - \frac{3}{4}\sin^2 2\theta\right)$

$$= (\sin 2\theta)^2 - 4\left(1 - \frac{5}{4}\sin^2 2\theta + \frac{3}{8}\sin^4 2\theta\right)$$

$$D = -\frac{3}{2}\sin^4 2\theta + 6\sin^2 2\theta - 4 > 0$$

$$3\sin^4 2\theta - 12\sin^2 2\theta + 8 < 0$$

$$\sin^2 2\theta = \frac{12 \pm \sqrt{12^2 - 12 \cdot 8}}{6} = \frac{12 \pm 4\sqrt{3}}{6} = \frac{6 \pm 2\sqrt{3}}{3}$$

$$\sin^2 2\theta = 2 \pm \frac{2}{\sqrt{3}}, \text{ but } \sin^2 2\theta \in [0, 1]$$

$$\therefore \alpha = 2 - \frac{2}{\sqrt{3}}, \beta = 1 \rightarrow (\alpha - 2)^2 = \frac{4}{3}, (\beta - 1)^2 = 0$$

$$\boxed{3(\alpha - 2)^2 + (\beta - 1)^2 = 4}$$

22. If $\int \operatorname{cosec}^5 x dx = \alpha \cot x \operatorname{cosec} x \left(\operatorname{cosec}^2 x + \frac{3}{2}\right) + \beta \log_e \left|\tan \frac{x}{2}\right| + C$

where $\alpha, \beta \in \mathbb{R}$ and C is constant of integration,

then the value of $8(\alpha + \beta)$ equals.....

Ans. (1)

Sol. $\int \operatorname{cosec}^3 x \cdot \operatorname{cosec}^2 x dx = I$

By applying integration by parts

$$I = -\cot x \operatorname{cosec}^3 x + \int \cot x (-3 \operatorname{cosec}^2 x \cot x \operatorname{cosec} x) dx$$

$$I = -\cot x \operatorname{cosec}^3 x - 3 \int \operatorname{cosec}^3 x (\operatorname{cosec}^2 x - 1) dx$$

$$I = -\cot x \operatorname{cosec}^3 x - 3I + 3 \int \operatorname{cosec}^3 x dx$$

let

$$I_1 = \int \operatorname{cosec}^3 x dx = -\operatorname{cosec} x \cot x - \int \cot^2 x \operatorname{cosec} x dx$$

$$I_1 = -\operatorname{cosec} x \cot x - \int (\operatorname{cosec}^2 x - 1) \operatorname{cosec} x dx$$

$$2I_1 = -\operatorname{cosec} x \cot x + \ln \left| \tan \frac{x}{2} \right|$$

$$I_1 = -\frac{1}{2} \operatorname{cosec} x \cot x + \frac{1}{2} \ln \left| \tan \frac{x}{2} \right|$$

$$4I = -\cot x \operatorname{cosec}^3 x - \frac{3}{2} \operatorname{cosec} x \cot x + \frac{3}{2} \ln \left| \tan \frac{x}{2} \right| + 4C$$

$$I = -\frac{1}{4} \operatorname{cosec} x \cot x \left(\operatorname{cosec}^2 x + \frac{3}{2} \right) + \frac{3}{8} \ln \left| \tan \frac{x}{2} \right| + C$$

$$\therefore \alpha = \frac{-1}{4}, \beta = \frac{3}{8} \rightarrow \boxed{8(\alpha + \beta) = 1}$$

23. Let $f : \mathbb{R} \rightarrow \mathbb{R}$ be a thrice differentiable function such that $f(0) = 0, f(1) = 1, f(2) = -1, f(3) = 2$ and $f(4) = -2$. Then, the minimum number of zeros of $(3f'f'' + ff''')(x)$ is.....

Ans. (5)

Sol. $(3f'f'' + ff''')(x) = ((ff'' + (f')^2)(x))'$

$$(ff'' + (f')^2)(x) = ((ff')(x))'$$

$$\therefore (3f'f'' + ff''')(x) = (f(x) \cdot f'(x))''$$

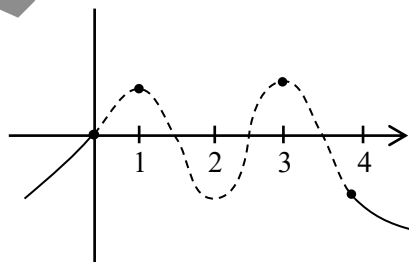

min. roots of $f(x) \rightarrow 4$

\therefore min. roots of $f'(x) \rightarrow 3$

\therefore min. roots of $(f(x) \cdot f'(x)) \rightarrow 7$

$$\boxed{\therefore \text{min. roots of } (f(x) \cdot f'(x))'' \rightarrow 5}$$

24. Consider the function $f : \mathbb{R} \rightarrow \mathbb{R}$ defined by

$$f(x) = \frac{2x}{\sqrt{1+9x^2}}. \text{ If the composition of}$$

$$f, \underbrace{(f \circ f \circ f \circ \dots \circ f)}_{10 \text{ times}}(x) = \frac{2^{10}x}{\sqrt{1+9\alpha x^2}}, \text{ then the}$$

value of $\sqrt{3\alpha+1}$ is equal to.....

Case-III : $|x - y| = 2 \Rightarrow x - y = \pm 2$

$$\begin{aligned} x - y = 2 \quad \text{OR} \quad x - y = -2 \\ \therefore x + y = 10 \quad \therefore x + y = 10 \\ x = 6, y = 4 \quad x = 4, y = 6 \end{aligned}$$

$$P(|x - y| = 2) = {}^{10}C_6 \left(\frac{1}{3}\right)^6 \left(\frac{2}{3}\right)^4 + {}^{10}C_4 \left(\frac{1}{3}\right)^4 \left(\frac{2}{3}\right)^6$$

$$p = {}^{10}C_5 \frac{2^5}{3^{10}} + {}^{10}C_6 \frac{2^4}{3^{10}} + {}^{10}C_4 \frac{2^6}{3^{10}}$$

$$3^9 p = \frac{1}{3} ({}^{10}C_5 2^5 + {}^{10}C_6 2^4 + {}^{10}C_4 2^6)$$

$$= 8288$$

28. Consider a triangle ABC having the vertices A(1,2), B(α , β) and C(γ , δ) and angles $\angle ABC = \frac{\pi}{6}$ and $\angle BAC = \frac{2\pi}{3}$. If the points B and C lie on the line $y = x + 4$, then $\alpha^2 + \gamma^2$ is equal to

Ans. (14)

Sol.

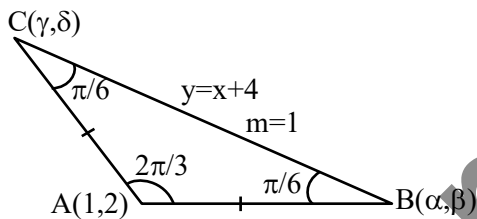

Equation of line passes through point A(1, 2)

which makes angle $\frac{\pi}{6}$ from $y = x + 4$ is

$$y - 2 = \frac{1 \pm \tan \frac{\pi}{6}}{1 \mp \tan \frac{\pi}{6}} (x - 1)$$

$$y - 2 = \frac{\sqrt{3} \pm 1}{\sqrt{3} \mp 1} (x - 1)$$

\oplus $y - 2 = (2 + \sqrt{3})(x - 1)$ <p style="text-align: center;">solve with $y = x + 4$</p> $x + 2 = (2 + \sqrt{3})x - 2 - \sqrt{3}$ $x = \frac{4 + \sqrt{3}}{1 + \sqrt{3}}$	\ominus $y - 2 = (2 - \sqrt{3})(x - 1)$ <p style="text-align: center;">solve with $y = x + 4$</p> $x + 2 = (2 - \sqrt{3})x - 2 + \sqrt{3}$ $x = \frac{4 - \sqrt{3}}{1 - \sqrt{3}}$
--	---

$$\alpha^2 + \gamma^2 = \left(\frac{4 + \sqrt{3}}{1 + \sqrt{3}}\right)^2 + \left(\frac{4 - \sqrt{3}}{1 - \sqrt{3}}\right)^2$$

$$\alpha^2 + \gamma^2 = 14$$

29. Consider a line L passing through the points P(1,2,1) and Q(2,1,-1). If the mirror image of the point A(2,2,2) in the line L is (α , β , γ), then $\alpha + \beta + 6\gamma$ is equal to

Ans. (6)

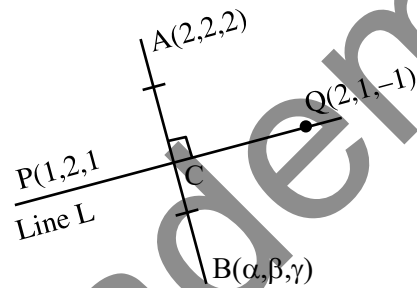

$$\text{DR's of Line L} \equiv -1 : 1 : 2$$

$$\text{DR's of AB} \equiv \alpha - 2 : \beta - 2 : \gamma - 2$$

$$AB \perp_{ar} L \Rightarrow 2 - \alpha + \beta - 2 + 2\gamma - 4 = 0$$

$$2\gamma + \beta - \alpha = 4 \quad \dots(1)$$

Let C is mid-point of AB

$$C\left(\frac{\alpha + 2}{2}, \frac{\beta + 2}{2}, \frac{\gamma + 2}{2}\right)$$

$$\text{DR's of PC} = \frac{\alpha}{2} : \frac{\beta - 2}{2} : \frac{\gamma}{2}$$

$$\text{line L} \parallel \text{PC} \Rightarrow \frac{-\alpha}{2} = \frac{\beta - 2}{2} = \frac{\gamma}{4} = K(\text{let})$$

$$\alpha = -2K$$

$$\beta = 2K + 2$$

$$\gamma = 4K$$

$$\text{use in (1)} \Rightarrow K = \frac{1}{6}$$

$$\text{value of } \alpha + \beta + 6\gamma = 24K + 2 = 6$$

30. Let $y = y(x)$ be the solution of the differential equation $(x + y + 2)^2 dx = dy$, $y(0) = -2$. Let the maximum and minimum values of the function

$y = y(x)$ in $\left[0, \frac{\pi}{3}\right]$ be α and β , respectively. If

$(3\alpha + \pi)^2 + \beta^2 = \gamma + \delta\sqrt{3}$, $\gamma, \delta \in \mathbb{Z}$, then $\gamma + \delta$ equals

.....

Ans. (31)

Sol. $\frac{dy}{dx} = (x + y + 2)^2 \dots(1), \quad y(0) = -2$

Let $x + y + 2 = v$

$$1 + \frac{dy}{dx} = \frac{dv}{dx}$$

from (1) $\frac{dv}{dx} = 1 + v^2$

$$\int \frac{dv}{1+v^2} = \int dx$$

$$\tan^{-1}(v) = x + C$$

$$\tan^{-1}(x + y + 2) = x + C$$

at $x = 0 \quad y = -2 \Rightarrow C = 0$

$$\Rightarrow \tan^{-1}(x + y + 2) = x$$

$$y = \tan x - x - 2$$

$$f(x) = \tan x - x - 2, \quad x \in \left[0, \frac{\pi}{3}\right]$$

$$f'(x) = \sec^2 x - 1 > 0 \Rightarrow f(x) \uparrow$$

$$f_{\min} = f(0) = -2 = \beta$$

$$f_{\max} = f\left(\frac{\pi}{3}\right) = \sqrt{3} - \frac{\pi}{3} - 2 = \alpha$$

now $(3\alpha + \pi)^2 + \beta^2 = \gamma + \delta\sqrt{3}$

$$\Rightarrow (3\alpha + \pi)^2 + \beta^2 = (3\sqrt{3} - 6)^2 + 4$$

$$\gamma + \delta\sqrt{3} = 67 - 36\sqrt{3}$$

$$\Rightarrow \gamma = 67 \text{ and } \delta = -36 \Rightarrow \gamma + \delta = 31$$

Toppers Academy

PHYSICS

TEST PAPER WITH SOLUTION

SECTION-A

31. The translational degrees of freedom (f_t) and rotational degrees of freedom (f_r) of CH_4 molecule are :

- (1) $f_t = 2$ and $f_r = 2$ (2) $f_t = 3$ and $f_r = 3$
 (3) $f_t = 3$ and $f_r = 2$ (4) $f_t = 2$ and $f_r = 3$

Ans. (2)

Sol. Since CH_4 is polyatomic Non-Linear
 D.O.F of CH_4
 T. DOF = 3
 R DOF = 3

32. A cyclist starts from the point P of a circular ground of radius 2 km and travels along its circumference to the point S. The displacement of a cyclist is :

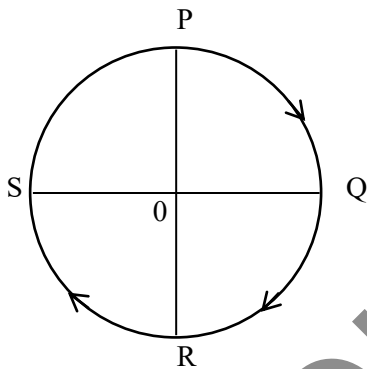

- (1) 6 km (2) $\sqrt{8}$ km
 (3) 4 km (4) 8 km

Ans. (2)

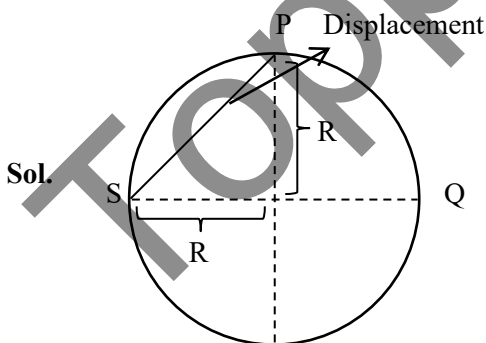

\therefore Displacement = $R\sqrt{2} = 2\sqrt{2} = \sqrt{8}$ km

33. The magnetic moment of a bar magnet is 0.5 Am^2 . It is suspended in a uniform magnetic field of $8 \times 10^{-2} \text{ T}$. The work done in rotating it from its most stable to most unstable position is :

- (1) $16 \times 10^{-2} \text{ J}$ (2) $8 \times 10^{-2} \text{ J}$
 (3) $4 \times 10^{-2} \text{ J}$ (4) Zero

Ans. (2)

Sol. At stable equilibrium

$U = -mB \cos 0^\circ = -mB$

At unstable equilibrium

$U = -mB \cos 180^\circ = +mB$

$W = \Delta U$

$W.D. = 2 mB$

$= 2 (0.5) 8 \times 10^{-2} = 8 \times 10^{-2} \text{ J}$

34. Which of the diode circuit shows correct biasing used for the measurement of dynamic resistance of p-n junction diode :

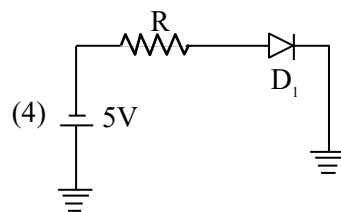
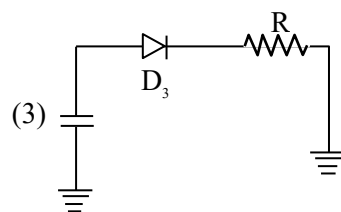
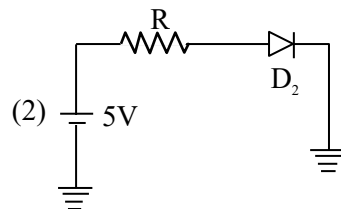
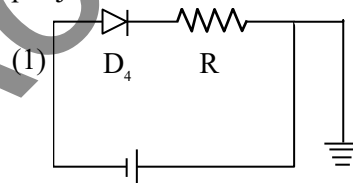

Ans. (2)

Sol. Diode should be in forward biased to calculate dynamic resistance

Hence correct answer would be 2.

35. Arrange the following in the ascending order of wavelength :

- (A) Gamma rays (λ_1) (B) x-ray (λ_2)
 (C) Infrared waves (λ_3) (D) Microwaves (λ_4)

Choose the most appropriate answer from the options given below :

- (1) $\lambda_4 < \lambda_3 < \lambda_1 < \lambda_2$ (2) $\lambda_4 < \lambda_3 < \lambda_2 < \lambda_1$
 (3) $\lambda_1 < \lambda_2 < \lambda_3 < \lambda_4$ (4) $\lambda_2 < \lambda_1 < \lambda_4 < \lambda_3$

Ans. (3)

Sol. $\lambda_1 < \lambda_2 < \lambda_3 < \lambda_4$

36. Identify the logic gate given in the circuit :

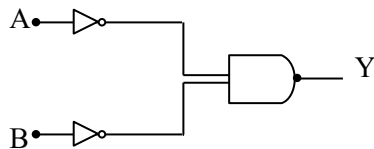

- (1) NAND - gate (2) OR - gate
 (3) AND gate (4) NOR gate

Ans. (2)

Sol. $Y = \overline{\overline{A} \cdot \overline{B}}$

By De-Morgan Law

$$Y = \overline{\overline{A} \cdot \overline{B}}$$

$$Y = A + B$$

Hence OR gate

37. The width of one of the two slits in a Young's double slit experiment is 4 times that of the other slit. The ratio of the maximum of the minimum intensity in the interference pattern is :

- (1) 9 : 1 (2) 16 : 1
 (3) 1 : 1 (4) 4 : 1

Ans. (1)

Sol. Since, Intensity \propto width of slit (ω)

so, $I_1 = I, I_2 = 4I$

$$I_{\min} = (\sqrt{I_1} - \sqrt{I_2})^2 = I$$

$$I_{\max} = (\sqrt{I_1} + \sqrt{I_2})^2 = 9I$$

$$\frac{I_{\max}}{I_{\min}} = \frac{9I}{I} = \frac{9}{1}$$

38. Correct formula for height of a satellite from earth's surface is :

$$(1) \left(\frac{T^2 R^2 g}{4\pi} \right)^{1/2} - R \quad (2) \left(\frac{T^2 R^2 g}{4\pi^2} \right)^{1/3} - R$$

$$(3) \left(\frac{T^2 R^2}{4\pi^2 g} \right)^{1/3} - R \quad (4) \left(\frac{T^2 R^2}{4\pi^2} \right)^{-1/3} + R$$

Ans. (2)

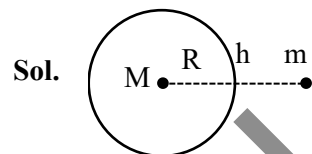

Sol.

$$\Rightarrow \frac{GMm}{(R+h)^2} = \frac{mv^2}{(R+h)}$$

$$\Rightarrow \frac{GM}{(R+h)} = v^2 \dots (1)$$

$$\Rightarrow v = (R+h)\omega$$

$$\Rightarrow v = (R+h) \frac{2\pi}{T} \dots (2)$$

$$\Rightarrow \frac{GM}{R^2} = g$$

$$\Rightarrow GM = gR^2 \dots (3)$$

Put value from (2) & (3) in eq. (1)

$$\Rightarrow \frac{gR^2}{(R+h)} = (R+h)^2 \left(\frac{2\pi}{T} \right)^2$$

$$\Rightarrow \frac{T^2 R^2 g}{(2\pi)^2} = (R+h)^3$$

$$\Rightarrow \left[\frac{T^2 R^2 g}{(2\pi)^2} \right]^{1/3} - R = h$$

39. Match List I with List II

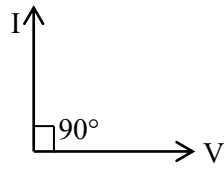
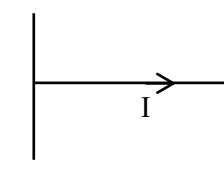
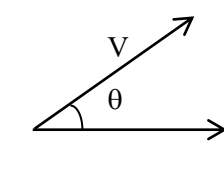
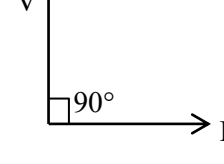
	List-I		List-II
A.	Purely capacitive circuit	I.	
B.	Purely inductive circuit	II.	
C.	LCR series at resonance	III.	
D.	LCR series circuit	IV.	

Choose the correct answer from the options given below :

- (1) A-I, B-IV, C-III, D-II
- (2) A-IV, B-I, C-III, D-II
- (3) A-IV, B-I, C-II, D-III
- (4) A-I, B-IV, C-II, D-III

Ans. (4)

Sol. A – V lags by 90° from I hence option (I) is correct.

B – V lead by 90° from I hence option (IV) is correct

C – In LCR resonance $X_L = X_C$. Hence circuit is purely resistive so option (II) is correct

D – In LCR series V is at some angle from I hence (III) is correct

Hence option (4) is correct.

40. Given below are two statements :

Statement I : The contact angle between a solid and a liquid is a property of the material of the solid and liquid as well.

Statement II : The rise of a liquid in a capillary tube does not depend on the inner radius of the tube.

In the light of the above statements, choose the correct answer from the options given below :

- (1) Both Statement I and Statement II are false
- (2) Statement I is false but Statement II is true.
- (3) Statement I is true but Statement II is false.
- (4) Both Statement I and Statement II are true.

Ans. (3)

Sol. Statement I is correct as we know contact angle depends on cohesive and adhesive forces.

Statement II is incorrect because height of liquid is given by $h = \frac{2T \cos \theta_c}{\rho g r}$ where r is radius of

Tube (assuming length of capillary is sufficient) Hence option (3) is correct.

41. A body of m kg slides from rest along the curve of vertical circle from point A to B in friction less path. The velocity of the body at B is :

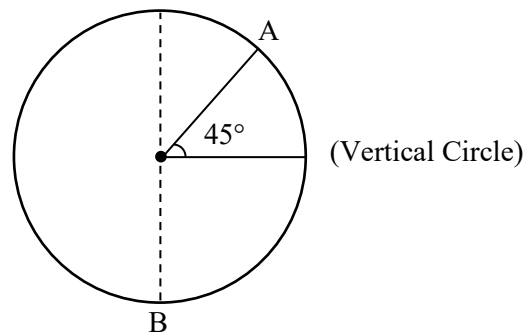

(given, $R = 14 \text{ m}$, $g = 10 \text{ m/s}^2$ and $\sqrt{2} = 1.4$)

- (1) 19.8 m/s
- (2) 21.9 m/s
- (3) 16.7 m/s
- (4) 10.6 m/s

Ans. (2)

Sol.

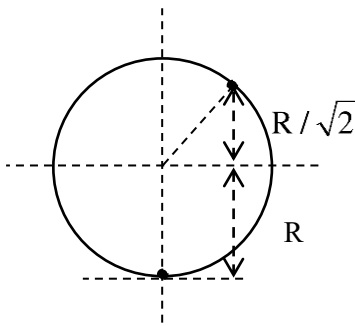

Apply W.E.T. from A to B

$$\Rightarrow W_{mg} = K_B - K_A$$

$$\Rightarrow mg \times \left(\frac{R}{\sqrt{2}} + R \right) = \frac{1}{2}mv_B^2 - 0 \quad \{v_A = 0 \text{ rest}\}$$

$$\Rightarrow mgR \frac{(\sqrt{2} + 1)}{\sqrt{2}} = \frac{1}{2}mv_B^2$$

$$\Rightarrow \sqrt{gR \frac{2(\sqrt{2} + 1)}{\sqrt{2}}} = v_B$$

$$\Rightarrow \sqrt{\frac{10 \times 14 \times 2(2.4)}{1.4}} = v_B$$

$$\Rightarrow 21.9 = v_B$$

Hence option (2) is correct

42. An electric bulb rated 50 W – 200 V is connected across a 100 V supply. The power dissipation of the bulb is :

- (1) 12.5 W (2) 25 W
(3) 50 W (4) 100 W

Ans. (1)

Sol. Rated power & voltage gives resistance

$$R = \frac{V^2}{P} = \frac{(200)^2}{50} = \frac{40000}{50}$$

$$R = 800$$

$$P = \frac{(V_{\text{applied}})^2}{R} = \frac{(100)^2}{800}$$

$$P = 12.5 \text{ watt}$$

Hence option 1 is correct.

43. A 2 kg brick begins to slide over a surface which is inclined at an angle of 45° with respect to horizontal axis. The co-efficient of static friction between their surfaces is :

- (1) 1 (2) $\frac{1}{\sqrt{3}}$
(3) 0.5 (4) 1.7

Ans. (1)

Sol.

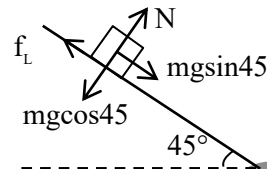

$$mg \sin 45 = f_L$$

$$mg \cos 45 = N$$

$$f_L = \mu_s N$$

$$\mu_s = \tan 45 = 1$$

or

$$\tan \theta = \mu_s \quad (\theta \text{ is angle of repose})$$

$$\tan 45 = \mu_s = 1$$

correct option (1)

44. In simple harmonic motion, the total mechanical energy of given system is E. If mass of oscillating particle P is doubled then the new energy of the system for same amplitude is :

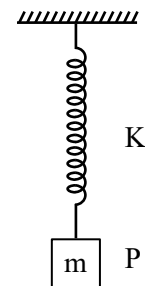

(1) $\frac{E}{\sqrt{2}}$ (2) E

(3) $E\sqrt{2}$ (4) 2E

Ans. (2)

Sol. T.E. = $\frac{1}{2}kA^2$

since A is same T.E. will be same
correct option (2)

45. Given below are two statements : one is labelled as **Assertion A** and the other is labelled as **Reason R**.
Assertion A : Number of photons increases with increase in frequency of light.

Reason R : Maximum kinetic energy of emitted electrons increases with the frequency of incident radiation.

In the light of the above statements, choose the **most appropriate** answer from the options given below :

- (1) Both **A** and **R** are correct and **R** is **NOT** the correct explanation of **A**.
 (2) **A** is correct but **R** is not correct.
 (3) Both **A** and **R** are correct and **R** is the correct explanation of **A**.
 (4) **A** is not correct but **R** is correct.

Ans. (4)

Sol. Intensity of light $I = \frac{nh\nu}{A}$

Here n is no. of photons per unit time.

$n = \frac{IA}{h\nu}$ so on increasing frequency ν , n decreases taking intensity constant.

$$K_{\max} = h\nu - \phi$$

So on increasing ν , kinetic energy increases.

46. According to Bohr's theory, the moment of momentum of an electron revolving in 4th orbit of hydrogen atom is :

- (1) $8 \frac{h}{\pi}$ (2) $\frac{h}{\pi}$
 (3) $2 \frac{h}{\pi}$ (4) $\frac{h}{2\pi}$

Ans. (3)

Sol. Moment of momentum is $\vec{r} \times \vec{P}$

$$\vec{L} = \vec{r} \times m\vec{v}$$

$$L = mvr = \frac{nh}{2\pi} = \frac{4h}{2\pi} = \frac{2h}{\pi}$$

47. A sample of gas at temperature T is adiabatically expanded to double its volume. Adiabatic constant for the gas is $\gamma = 3/2$. The work done by the gas in the process is : ($\mu = 1$ mole)

- (1) $RT[\sqrt{2} - 2]$ (2) $RT[1 - 2\sqrt{2}]$
 (3) $RT[2\sqrt{2} - 1]$ (4) $RT[2 - \sqrt{2}]$

Ans. (4)

Sol. $W = \frac{nR\Delta T}{1 - \gamma}$

$$TV^{\gamma-1} = \text{constant} = T_f(2V)^{\gamma-1}$$

$$T_f = T \left(\frac{1}{2}\right)^{1/2} = \frac{T}{\sqrt{2}}$$

$$W = \frac{R \left(\frac{T}{\sqrt{2}} - T\right)}{1 - \frac{3}{2}} = 2RT \frac{(\sqrt{2} - 1)}{\sqrt{2}}$$

$$= RT(2 - \sqrt{2})$$

48. A charge q is placed at the center of one of the surface of a cube. The flux linked with the cube is :-

- (1) $\frac{q}{4\epsilon_0}$ (2) $\frac{q}{2\epsilon_0}$
 (3) $\frac{q}{8\epsilon_0}$ (4) Zero

Ans. (2)

Sol. From

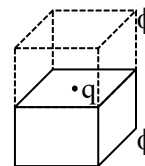

$$2\phi = \frac{q}{\epsilon_0}$$

$$\phi = \frac{q}{2\epsilon_0}$$

49. Applying the principle of homogeneity of dimensions, determine which one is correct.
where T is time period, G is gravitational constant, M is mass, r is radius of orbit.

$$(1) T^2 = \frac{4\pi^2 r}{GM^2} \quad (2) T^2 = 4\pi^2 r^3$$

$$(3) T^2 = \frac{4\pi^2 r^3}{GM} \quad (4) T^2 = \frac{4\pi^2 r^2}{GM}$$

Ans. (3)

Sol. According to principle of homogeneity dimension of LHS should be equal to dimensions of RHS so option (3) is correct.

$$T^2 = \frac{4\pi^2 r^3}{GM}$$

$$[T^2] = \frac{[L^3]}{[M^{-1}L^3T^{-2}][M]}$$

(Dimension of G is $[M^{-1}L^3T^{-2}]$)

$$[T^2] = \frac{[L^3]}{[L^3T^{-2}]} = [T^2]$$

50. A 90 kg body placed at 2R distance from surface of earth experiences gravitational pull of :
(R = Radius of earth, $g = 10 \text{ ms}^{-2}$)
- (1) 300 N (2) 225 N
(3) 120 N (4) 100 N

Ans. (4)

Sol. Value of $g = g_s \left(1 + \frac{h}{R}\right)^{-2}$

$$= g_s (1+2)^{-2} = \frac{g_s}{9}$$

Here g_s = gravitational acceleration at surface

$$\text{Force} = mg = 90 \times \frac{g_s}{9} = 100 \text{ N}$$

SECTION-B

51. The displacement of a particle executing SHM is given by $x = 10 \sin \left(\omega t + \frac{\pi}{3} \right) \text{ m}$. The time period of motion is 3.14 s. The velocity of the particle at $t = 0$ is _____ m/s.

Ans. (10)

Sol. Given,

$$T = 3.14 = \frac{2\pi}{\omega}$$

$$\omega = 2 \text{ rad/s}$$

$$x = 10 \sin \left(\omega t + \frac{\pi}{3} \right)$$

$$v = \frac{dx}{dt} = 10\omega \cos \left(\omega t + \frac{\pi}{3} \right)$$

at $t = 0$

$$v = 10\omega \cos \left(\frac{\pi}{3} \right) = 10 \times 2 \times \frac{1}{2} \text{ [using } \omega = 2 \text{ rad/s]}$$

$$v = 10 \text{ m/s}$$

52. A bus moving along a straight highway with speed of 72 km/h is brought to halt within 4s after applying the brakes. The distance travelled by the bus during this time (Assume the retardation is uniform) is _____ m.

Ans. (40)

Sol. Initial velocity = $u = 72 \text{ km/h} = 20 \text{ m/s}$

$$v = u + at$$

$$\Rightarrow 0 = 20 + a \times 4$$

$$a = -5 \text{ m/s}^2$$

$$v^2 - u^2 = 2as$$

$$\Rightarrow 0^2 - 20^2 = 2(-5)s$$

$$s = 40 \text{ m}$$

53. A parallel plate capacitor of capacitance 12.5 pF is charged by a battery connected between its plates to potential difference of 12.0 V. The battery is now disconnected and a dielectric slab ($\epsilon_r = 6$) is inserted between the plates. The change in its potential energy after inserting the dielectric slab is _____ $\times 10^{-12} \text{ J}$.

Ans. (750)

Sol. Before inserting dielectric capacitance is given $C_0 = 12.5 \text{ pF}$ and charge on the capacitor $Q = C_0 V$
After inserting dielectric capacitance will become $\epsilon_r C_0$.

Change in potential energy of the capacitor
 $= E_i - E_f$

$$= \frac{Q^2}{2C_i} - \frac{Q^2}{2C_f} = \frac{Q^2}{2C_0} \left[1 - \frac{1}{\epsilon_r} \right]$$

$$= \frac{(C_0 V)^2}{2C_0} \left[1 - \frac{1}{\epsilon_r} \right] = \frac{1}{2} C_0 V^2 \left[1 - \frac{1}{\epsilon_r} \right]$$

Using $C_0 = 12.5 \text{ pF}$, $V = 12 \text{ V}$, $\epsilon_r = 6$

$$= \frac{1}{2} (12.5) \times 12^2 \left[1 - \frac{1}{6} \right] = \frac{1}{2} (12.5) \times 12^2 \times \frac{5}{6}$$

$$= 750 \text{ pJ} = 750 \times 10^{-12} \text{ J}$$

54. In a system two particles of masses $m_1 = 3 \text{ kg}$ and $m_2 = 2 \text{ kg}$ are placed at certain distance from each other. The particle of mass m_1 is moved towards the center of mass of the system through a distance 2 cm . In order to keep the center of mass of the system at the original position, the particle of mass m_2 should move towards the center of mass by the distance ____ cm.

Ans. (3)

Sol. $m_1 = 3 \text{ kg}$ $m_2 = 2 \text{ kg}$

$$\Delta X_{\text{C.O.M.}} = \frac{m_1 \Delta x_1 + m_2 \Delta x_2}{m_1 + m_2}$$

$$\Rightarrow 0 = \frac{3 \times 2 + 2(-x)}{3 + 2}$$

$$\Rightarrow x = 3 \text{ cm}$$

55. The disintegration energy Q for the nuclear fission of $^{235}\text{U} \rightarrow ^{140}\text{Ce} + ^{94}\text{Zr} + n$ is ____ MeV.

Given atomic masses of

$^{235}\text{U} : 235.0439 \text{ u}$, $^{140}\text{Ce} : 139.9054 \text{ u}$,

$^{94}\text{Zr} : 93.9063 \text{ u}$; $n : 1.0086 \text{ u}$,

Value of $c^2 = 931 \text{ MeV/u}$.

Ans. (208)

Sol. $^{235}\text{U} \rightarrow ^{140}\text{Ce} + ^{94}\text{Zr} + n$

Disintegration energy

$$Q = (m_R - m_P) \cdot c^2$$

$$m_R = 235.0439 \text{ u}$$

$$m_P = 139.9054 \text{ u} + 93.9063 \text{ u} + 1.0086 \text{ u}$$

$$= 234.8203 \text{ u}$$

$$Q = (235.0439 \text{ u} - 234.8203 \text{ u}) c^2$$

$$= 0.2236 \text{ u} c^2$$

$$= 0.2236 \times 931$$

$$Q = 208.1716$$

56. A light ray is incident on a glass slab of thickness $4\sqrt{3} \text{ cm}$ and refractive index $\sqrt{2}$. The angle of incidence is equal to the critical angle for the glass slab with air. The lateral displacement of ray after passing through glass slab is ____ cm.
(Given $\sin 15^\circ = 0.25$)

Ans. (2)

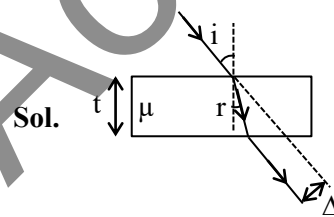

$$i = \theta_c$$

$$\Rightarrow i = \sin^{-1} \left(\frac{1}{\mu} \right)$$

$$\Rightarrow i = 45^\circ$$

and according to snell's law

$$1 \sin 45^\circ = \sqrt{2} \sin r$$

$$\Rightarrow r = 30^\circ$$

$$\text{Lateral displacement } \Delta = \frac{t \sin(i - r)}{\cos r}$$

$$\Rightarrow \Delta = \frac{4\sqrt{3} \times \sin 15^\circ}{\cos 30^\circ}$$

$$\Rightarrow \Delta = 2 \text{ cm}$$

57. A rod of length 60 cm rotates with a uniform angular velocity 20 rad s^{-1} about its perpendicular bisector, in a uniform magnetic field 0.5 T . The direction of magnetic field is parallel to the axis of rotation. The potential difference between the two ends of the rod is ____ V.

Ans. (0)

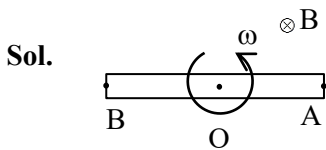

$$\therefore V_0 - V_A = \frac{B\omega l^2}{2}$$

$$V_0 - V_B = \frac{B\omega l^2}{2}$$

$$\therefore V_A = V_B \therefore V_A - V_B = 0$$

58. Two wires A and B are made up of the same material and have the same mass. Wire A has radius of 2.0 mm and wire B has radius of 4.0 mm . The resistance of wire B is 2Ω . The resistance of wire A is ____ Ω .

Ans. (32)

Sol. $\therefore R = \frac{\rho l}{A} = \frac{\rho V}{A^2}$

$$\therefore \frac{R_A}{R_B} = \frac{A_B^2}{A_A^2} = \frac{r_B^4}{r_A^4}$$

$$\Rightarrow \frac{R_A}{2} = \left[\frac{4 \times 10^{-3}}{2 \times 10^{-3}} \right]^4$$

$$\Rightarrow R_A = 32 \Omega.$$

59. Two parallel long current carrying wire separated by a distance $2r$ are shown in the figure. The ratio of magnetic field at A to the magnetic field produced at C is $\frac{x}{7}$. The value of x is ____.

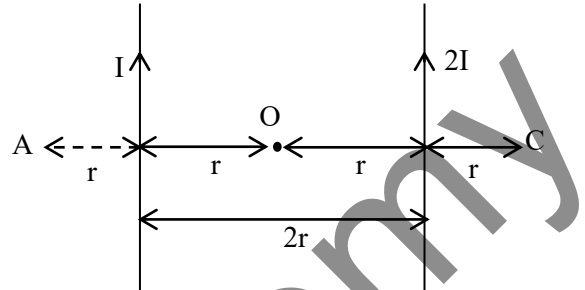

Ans. (5)

Sol. $B_A = \frac{\mu_0 i}{2\pi r} + \frac{\mu_0 (2i)}{2\pi (3r)} = \frac{5\mu_0 i}{6\pi r}$

$$B_C = \frac{\mu_0 (2i)}{2\pi r} + \frac{\mu_0 i}{2\pi (3r)} = \frac{7\mu_0 i}{6\pi r}$$

$$\therefore \frac{B_A}{B_C} = \frac{5}{7}$$

$$\therefore x = 5$$

60. Mercury is filled in a tube of radius 2 cm up to a height of 30 cm . The force exerted by mercury on the bottom of the tube is ____ N.

(Given, atmospheric pressure = 10^5 Nm^{-2} , density of mercury = $1.36 \times 10^4 \text{ kg m}^{-3}$, $g = 10 \text{ ms}^{-2}$, $\pi = \frac{22}{7}$)

Ans. (177)

Sol. $F = P_0 A + \rho_m g h A$

$$= 10^5 \times \frac{22}{7} \times (2 \times 10^{-2})^2$$

$$+ 1.36 \times 10^4 \times 10 \times (30 \times 10^{-2}) \left(\frac{22}{7} \times (2 \times 10^{-2})^2 \right)$$

$$F = 51.29 + 125.71 = 177 \text{ N}$$

Sol. (A) Generally hydrogen bonding exists when H is covalently bonded to the highly electronegative atom like F, O, N.

(B) Intramolecular H bonding is present in

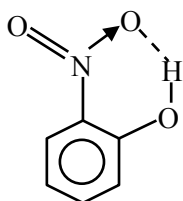

(C) Intermolecular Hydrogen bonding is present in HF

(D) The magnitude has Hydrogen bonding in solid state is greater than liquid state.

(E) Hydrogen bonding has powerful effect on the structure & properties of compound like melting point, boiling point, density etc.

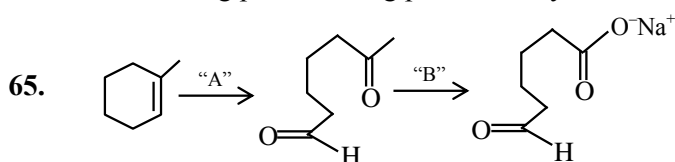

In the above chemical reaction sequence "A" and "B" respectively are :

- (1) $O_3, Zn/H_2O$ and $NaOH_{(alc.)} / I_2$
- (2) H_2O, H^+ and $NaOH_{(alc.)} / I_2$
- (3) H_2O, H^+ and $KMnO_4$
- (4) $O_3, Zn/H_2O$ and $KMnO_4$

Ans. (1)

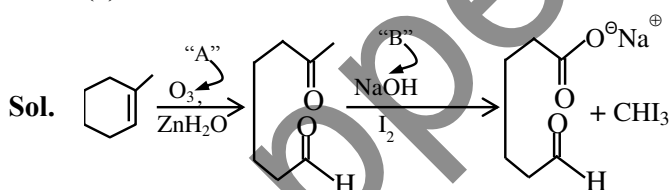

66. Common name of Benzene-1, 2-diol is

- (1) quinol
- (2) resorcinol
- (3) catechol
- (4) o-cresol

Ans. (3)

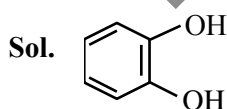

IUPAC name : Benzene-1,2-diol

Common name : catechol

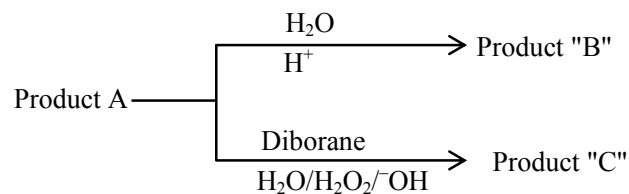
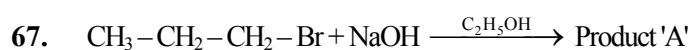

Consider the above reactions, identify product B and product C.

- (1) B = C = 2-Propanol
- (2) B = 2-Propanol C = 1-Propanol
- (3) B = 1-Propanol C = 2-Propanol
- (4) B = C = 1-Propanol

Ans. (2)

Sol.

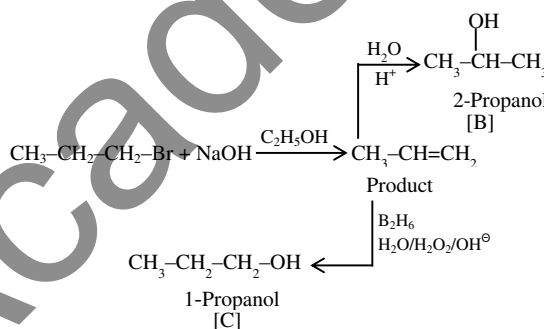

68. The adsorbent used in adsorption chromatography is/are

- A. silica gel
- B. alumina
- C. quick lime
- D. magnesia

Choose the **most appropriate** answer from the options given below :

- (1) B only
- (2) C and D only
- (3) A and B only
- (4) A only

Ans. (3)

Sol. The most common polar and acidic support used in adsorption chromatography is silica. The surface silanol groups on their supported to adsorb polar compound and work particularly well for basic substances. Alumina is the example of polar and basic adsorbent that is used in adsorption chromatography.

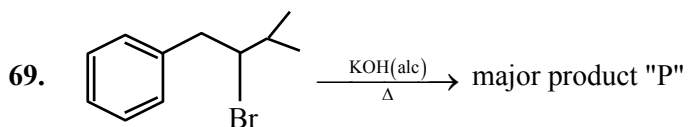

Product P is

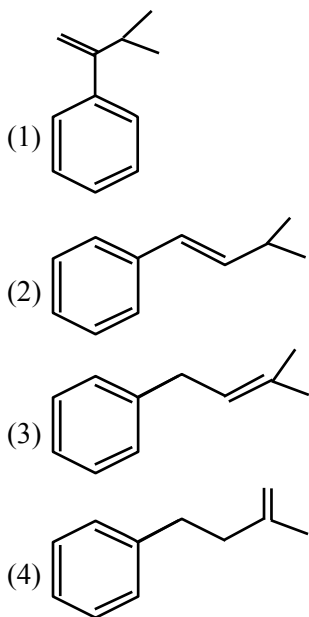

Ans. (2)

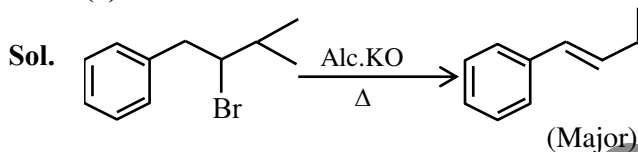

70. Correct order of stability of carbanion is

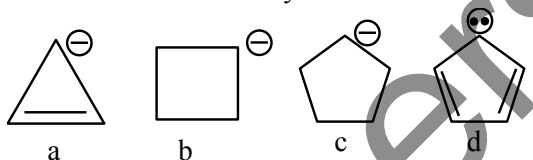

- (1) $c > b > d > a$ (2) $a > b > c > d$
 (3) $d > a > c > b$ (4) $d > c > b > a$

Ans. (4)

Sol. As we know compound (d) is aromatic and the compound (a) is anti-aromatic. Hence compound (d) is most stable and compound (a) is least stable among these in compound (b) and (c) carbon atom of that positive charge is sp^3 hybridised they on the basis of angle strain theory compound (c) is more stable than compound (b).

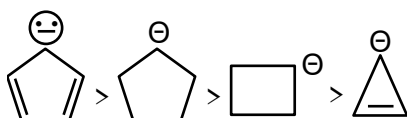

71. The correct order of the first ionization enthalpy is
 (1) $Al > Ga > Tl$ (2) $Ga > Al > B$
 (3) $B > Al > Ga$ (4) $Tl > Ga > Al$

Ans. (4)

Sol. (i) due to lanthanide contraction Tl has more I.E. as compared to Ga and Al

(ii) due to scandide contraction Ga has more I.E. as compared to Al

72. If an iron (III) complex with the formula $[Fe(NH_3)_x(CN)_y]^-$ has no electron in its e_g orbital, then the value of $x + y$ is
 (1) 5 (2) 6
 (3) 3 (4) 4

Ans. (2)

Sol. Complex is $[Fe^{III}(NH_3)_2(CN)_4]^-$
 $x = 2$
 $y = 4$
 so $x + y = 6$

73. Fuel cell, using hydrogen and oxygen as fuels,
 A. has been used in spaceship
 B. has an efficiency of 40% to produce electricity
 C. uses aluminium as catalysts
 D. is eco-friendly
 E. is actually a type of Galvanic cell only
 (1) A,B,C only (2) A,B,D only
 (3) A,B,D,E only (4) A,D,E only

Ans. (4)

Sol. Fuel cell is used in spaceship and it is type of galvanic cell.

74. Choose the **Incorrect** Statement about Dalton's Atomic Theory
 (1) Compounds are formed when atoms of different elements combine in any ratio
 (2) All the atoms of a given element have identical properties including identical mass
 (3) Matter consists of indivisible atoms
 (4) Chemical reactions involve reorganization of atoms

Ans. (1)

Sol. In compound atoms of different elements combine in fixed ratio by mass.

75. Match List I with List II

	LIST I		LIST II
A.	α - Glucose and α -Galactose	I.	Functional isomers
B.	α - Glucose and β -Glucose	II.	Homologous
C.	α - Glucose and α -Fructose	III.	Anomers
D.	α - Glucose and α -Ribose	IV.	Epimers

Choose the **correct** answer from the options given below:

- (1) A-III, B-IV, C-II, D-I
 (2) A-III, B-IV, C-I, D-II
 (3) A-IV, B-III, C-I, D-II
 (4) A-IV, B-III, C-II, D-I

Ans. (3)

Sol. Based on biomolecules theory and structure of these named compounds –

- (A) α -Glucose and α -Galactose (IV) Epimers.
 (B) α -Glucose and β -Glucose (III) Anomers
 (C) α -Glucose and α -Fructose (I) Functional isomers
 (D) α -Glucose and α -Ribose (II) Homologous

76. Given below are two statements:

Statement I : The correct order of first ionization enthalpy values of Li, Na, F and Cl is $\text{Na} < \text{Li} < \text{Cl} < \text{F}$.

Statement II : The correct order of negative electron gain enthalpy values of Li, Na, F and Cl is $\text{Na} < \text{Li} < \text{F} < \text{Cl}$

In the light of the above statements, choose the **correct** answer from the options given below :

- (1) Both Statement I and Statement II are true
 (2) Both Statement I and Statement II are false
 (3) Statement I is false but Statement II is true
 (4) Statement I is true but Statement II is false

Ans. (1)

Sol.. (i) $\text{Na} < \text{Li} < \text{Cl} < \text{F}$
 $\downarrow \quad \downarrow \quad \downarrow \quad \downarrow$
 I.E.₁ in kJ/mol 496 520 1256 1681

(ii) $\text{Na} < \text{Li} < \text{F} < \text{Cl}$
 $\downarrow \quad \downarrow \quad \downarrow \quad \downarrow$
 $\Delta_{\text{eg}}\text{H}$ in kJ/mol -53 -60 -328 -349

77. For a strong electrolyte, a plot of molar conductivity against (concentration)^{1/2} is a straight line, with a negative slope, the correct unit for the slope is

- (1) $\text{S cm}^2 \text{ mol}^{-3/2} \text{ L}^{1/2}$ (2) $\text{S cm}^2 \text{ mol}^{-1} \text{ L}^{1/2}$
 (3) $\text{S cm}^2 \text{ mol}^{-3/2} \text{ L}$ (4) $\text{S cm}^2 \text{ mol}^{-3/2} \text{ L}^{-1/2}$

Ans. (1)

Sol. $\Lambda_m = \Lambda_m^\circ - A\sqrt{C}$

Units of $A\sqrt{C} = \text{S cm}^2 \text{ mole}^{-1}$

Units of $A = \text{S cm}^2 \text{ mole}^{-3/2} \text{ L}^{1/2}$

78. A first row transition metal in its +2 oxidation state has a spin-only magnetic moment value of 3.86 BM.

The atomic number of the metal is

- (1) 25 (2) 26
 (3) 22 (4) 23

Ans. (4)

Sol. ${}_{22}\text{Ti}^{+2} \Rightarrow [\text{Ar}]3d^2$

${}_{23}\text{V}^{+2} \Rightarrow [\text{Ar}]3d^3$

${}_{25}\text{Mn}^{+2} \Rightarrow [\text{Ar}]3d^5$

${}_{26}\text{Fe}^{+2} \Rightarrow [\text{Ar}]3d^6$

79. The number of unpaired d-electrons in

$[\text{Co}(\text{H}_2\text{O})_6]^{3+}$ is _____

- (1) 4 (2) 2
 (3) 0 (4) 1

Ans. (3)

Sol. $\Rightarrow [\text{Co}(\text{H}_2\text{O})_6]^{+3}$

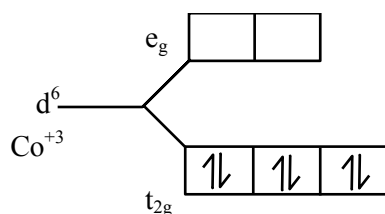

No unpaired electrons

80. The number of species from the following that have pyramidal geometry around the central atom is _____

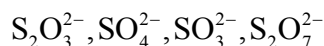

- (1) 4 (2) 3
(3) 1 (4) 2

Ans. (3)

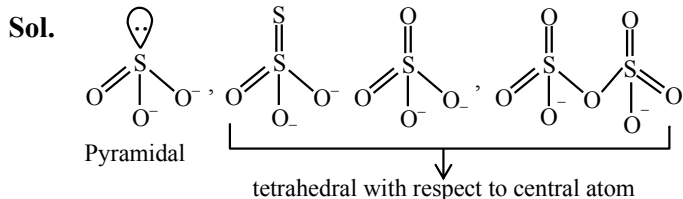

SECTION-B

81. The maximum number of orbitals which can be identified with $n = 4$ and $m_l = 0$ is _____

Ans. (4)

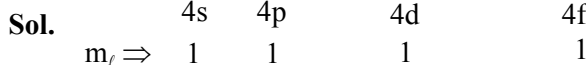
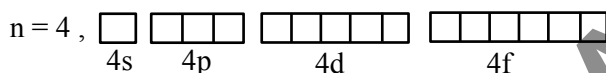

So answer is 4.

82. Number of compounds/species from the following with non-zero dipole moment is _____

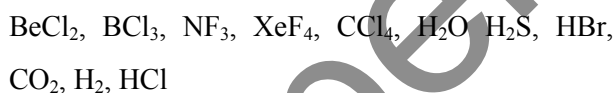

Ans. (5)



83. Three moles of an ideal gas are compressed isothermally from 60 L to 20 L using constant pressure of 5 atm. Heat exchange Q for the compression is - _____ Lit. atm.

Ans. (200)

Sol. As isothermal $\Delta U = 0$

and process is irreversible

$$Q = -W = -[-P_{\text{ext}}(V_2 - V_1)]$$

$$Q = 5(20 - 60) = -200 \text{ atm-L}$$

84. From 6.55 g of aniline, the maximum amount of acetanilide that can be prepared will be $___ \times 10^{-1}$ g.

Ans. (95)

Sol.

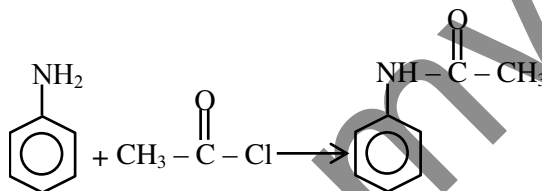

93 g aniline form 135 gm acetanilide

$$\text{so } 6.55 \text{ g aniline form } \frac{135}{93} \times 6.55 = 9.5$$

$$95 \times 10^{-1}$$

85. Consider the following reaction, the rate expression of which is given below



$$\text{rate} = k[A]^{1/2}[B]^{1/2}$$

The reaction is initiated by taking 1M concentration A and B each. If the rate constant (k) is $4.6 \times 10^{-2} \text{ s}^{-1}$, then the time taken for A to become 0.1 M is _____ sec. (nearest integer)

Ans. (50)

Sol. $K = \frac{2.303}{t} \log \frac{1}{0.1}$

$$4.6 \times 10^{-2} = \frac{2.303}{t}$$

$$t = 50 \text{ sec.}$$

86. Phthalimide is made to undergo following sequence of reactions.

(i) KOH

(ii) Benzylchloride

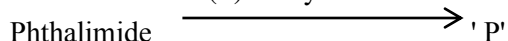

Total number of π bonds present in product 'P' is/are

Ans. (8)

Sol.

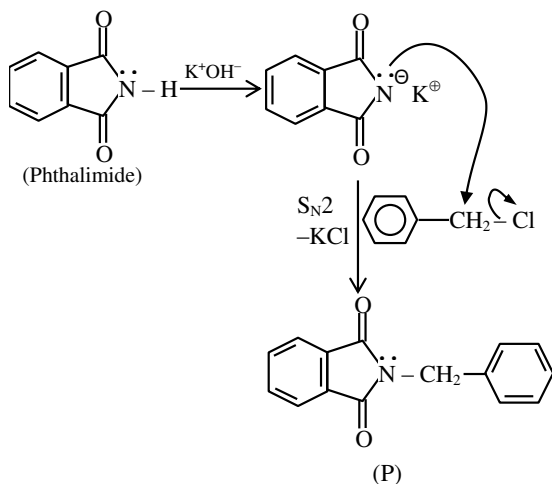

Total number of π -bonds present in product P is 8

87. The total number of 'sigma' and 'Pi' bonds in 2-oxohex-4-ynoic acid is ____.

Ans. (18)

Sol.

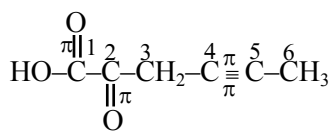

2-Oxohex-4-ynoic acid

Number of σ -bonds = 14

Number of π -bonds = 4

= 18

88. A first row transition metal with highest enthalpy of atomisation, upon reaction with oxygen at high temperature forms oxides of formula M_2O_n (where $n = 3, 4, 5$). The 'spin-only' magnetic moment value of the amphoteric oxide from the above oxides is ____ BM (near integer)

(Given atomic number : Sc : 21, Ti : 22, V : 23,

Cr : 24, Mn : 25, Fe : 26, Co : 27, Ni : 28, Cu : 29,

Zn : 30)

Ans. (0)

Sol. 'V' has highest enthalpy of atomisation (515 kJ/mol) among first row transition elements.

V_2O_5

Here 'V' is in +5 oxidation state

$V^{+5} \Rightarrow 1s^2 2s^2 2p^6 3s^2 3p^6$ (no unpaired electrons)

89. 2.7 Kg of each of water and acetic acid are mixed, The freezing point of the solution will be $-x$ °C. Consider the acetic acid does not dimerise in water, nor dissociates in water $x =$ ____ (nearest integer)

[Given : Molar mass of water = 18 g mol^{-1} , acetic acid = 60 g mol^{-1}]

$K_f \text{ H}_2\text{O} : 1.86 \text{ K kg mol}^{-1}$

$K_f \text{ acetic acid} : 3.90 \text{ K kg mol}^{-1}$

freezing point : $\text{H}_2\text{O} = 273 \text{ K}$, acetic acid = 290 K]

Ans. (31)

Sol. As moles of water > moles of CH_3COOH water is solvent.

$T^\circ_F - (T_F)_S = K_F \times M$

$$0 - (T_F)_S = 1.86 \times \frac{2700 / 60}{2700 / 1000}$$

$(T_F)_S = -31^\circ\text{C}$.

90. Vanillin compound obtained from vanilla beans, has total sum of oxygen atoms and π electrons is ____

Ans. (11)

Sol. Vanillin compound is an organic compound molecular formula $\text{C}_8\text{H}_8\text{O}_3$. It is a phenolic aldehyde. Its functional compounds include aldehyde, hydroxyl and ether. It is the primary component of the extract of the vanilla beans.

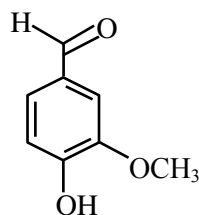

Total sum of oxygen atoms and π -electrons is $3 + 8 = 11$

Total number of oxygen atoms = 3

Total number of π -bonds = 4

\therefore Total number of π -electrons = 8

FINAL JEE–MAIN EXAMINATION – APRIL, 2024

(Held On Friday 05th April, 2024)

TIME : 9 : 00 AM to 12 : 00 NOON

MATHEMATICS

TEST PAPER WITH SOLUTION

SECTION-A

1. Let d be the distance of the point of intersection of the lines $\frac{x+6}{3} = \frac{y}{2} = \frac{z+1}{1}$ and

$\frac{x-7}{4} = \frac{y-9}{3} = \frac{z-4}{2}$ from the point $(7, 8, 9)$. Then

$d^2 + 6$ is equal to :

- (1) 72 (2) 69
(3) 75 (4) 78

Ans. (3)

Sol. $\frac{x+6}{3} = \frac{y}{2} = \frac{z+1}{1} = \lambda \quad \dots(1)$

$x = 3\lambda - 6, y = 2\lambda, z = \lambda - 1$

$\frac{x-7}{4} = \frac{y-9}{3} = \frac{z-4}{2} = \mu \quad \dots(2)$

$x = 4\mu + 7, y = 3\mu + 9, z = 2\mu + 4$

$3\lambda - 6 = 4\mu + 7 \Rightarrow 3\lambda - 4\mu = 13 \quad \dots(3) \times 2$

$2\lambda = 3\mu + 9 \Rightarrow 2\lambda - 3\mu = 9 \quad \dots(4) \times 3$

$6\lambda - 8\mu = 26$

$6\lambda - 9\mu = 27$

$\begin{array}{r} - \quad + \quad - \\ \hline \end{array}$

$\mu = -1$

$\Rightarrow 3\lambda - 4(-1) = 13$

$3\lambda = 9$

$\lambda = 3$

int. point $(3, 6, 2)$; $(7, 8, 9)$

$d^2 = 16 + 4 + 49 = 69$

Ans. $d^2 + 6 = 69 + 6 = 75$

2. Let a rectangle ABCD of sides 2 and 4 be inscribed in another rectangle PQRS such that the vertices of the rectangle ABCD lie on the sides of the rectangle PQRS. Let a and b be the sides of the rectangle PQRS when its area is maximum. Then $(a + b)^2$ is equal to :

- (1) 72 (2) 60
(3) 80 (4) 64

Ans. (1)

Sol.

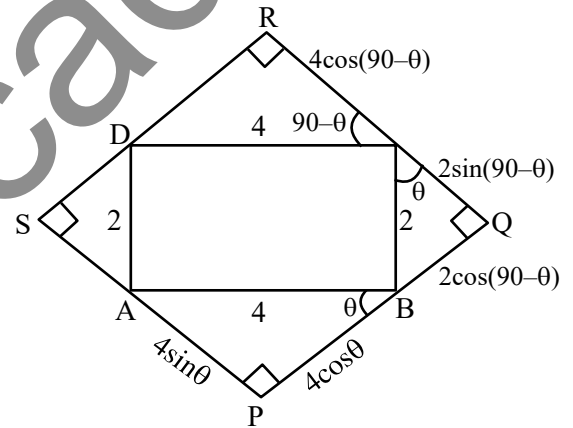

Area = $(4\cos\theta + 2\sin\theta)(2\cos\theta + 4\sin\theta)$
 $= 8\cos^2\theta + 16\sin\theta\cos\theta + 4\sin\theta\cos\theta + 8\sin^2\theta$
 $= 8 + 20\sin\theta\cos\theta$
 $= 8 + 10\sin 2\theta$
 Max Area = $8 + 10 = 18$ ($\sin 2\theta = 1$) $\theta = 45^\circ$
 $(a + b)^2 = (4\cos\theta + 2\sin\theta + 2\cos\theta + 4\sin\theta)^2$
 $= (6\cos\theta + 6\sin\theta)^2$
 $= 36(\sin\theta + \cos\theta)^2$
 $= 36(\sqrt{2})^2$
 $= 72$

3. Let two straight lines drawn from the origin O intersect the line $3x + 4y = 12$ at the points P and Q such that ΔOPQ is an isosceles triangle and $\angle POQ = 90^\circ$. If $l = OP^2 + PQ^2 + QO^2$, then the greatest integer less than or equal to l is :

- (1) 44 (2) 48
 (3) 46 (4) 42

Ans. (3)

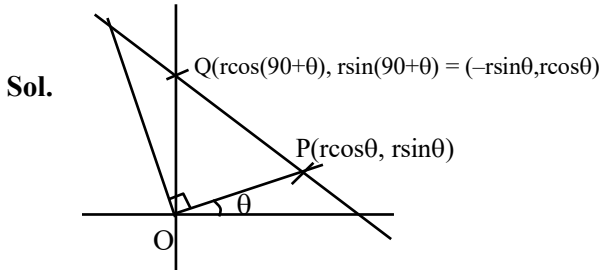

$$3x + 4y = 12$$

$$3(r \cos \theta) + 4(r \sin \theta) = 12$$

$$r(3 \cos \theta + 4 \sin \theta) = 12 \quad \dots(1)$$

$$3(-r \sin \theta) + 4(r \cos \theta) = 12$$

$$r(-3 \sin \theta + 4 \cos \theta) = 12 \quad \dots(2)$$

$$\left(\frac{12}{r}\right)^2 + \left(\frac{12}{r}\right)^2 = (3 \cos \theta + 4 \sin \theta)^2 + (-3 \sin \theta + 4 \cos \theta)^2$$

$$2\left(\frac{12}{r}\right)^2 = 9 + 16$$

$$\frac{2 \times 144}{r^2} = 25 \Rightarrow 288 = 25r^2$$

$$\Rightarrow \frac{288}{25} = r^2$$

$$\Rightarrow \sqrt{2} \left(\frac{12}{5}\right) = r$$

$$l = OP^2 + PQ^2 + QO^2$$

$$l = r^2 + r^2 + r^2(\cos \theta + \sin \theta)^2 + r^2(\sin \theta + \cos \theta)^2$$

$$= 2r^2 + r^2(1 + \sin 2\theta + 1 - 2 \sin 2\theta)$$

$$= 2r^2 + 2r^2$$

$$= 4r^2$$

$$= 4\left(\frac{288}{25}\right) = \frac{1152}{25} = 46.08$$

$$[l] = 46$$

4. If $y = y(x)$ is the solution of the differential equation $\frac{dy}{dx} + 2y = \sin(2x)$, $y(0) = \frac{3}{4}$, then

$y\left(\frac{\pi}{8}\right)$ is equal to :

- (1) $e^{-\pi/8}$ (2) $e^{-\pi/4}$
 (3) $e^{\pi/4}$ (4) $e^{\pi/8}$

Ans. (2)

Sol. $\frac{dy}{dx} + 2y = \sin 2x$, $y(0) = \frac{3}{4}$

$$I.F = e^{\int 2 dx} = e^{2x}$$

$$y \cdot e^{2x} = \int e^{2x} \sin 2x dx$$

$$y \cdot e^{2x} = \frac{e^{2x}(2 \sin 2x - 2 \cos 2x)}{4 + 4} + C$$

$$x = 0, y = \frac{3}{4} \Rightarrow \frac{3}{4} \cdot 1 = \frac{1(0 - 2)}{8} + C$$

$$\frac{3}{4} = -\frac{1}{4} + C$$

$$1 = C$$

$$y = \frac{2 \sin 2x - 2 \cos 2x}{8} + 1 \cdot e^{-2x}$$

$$x = \frac{\pi}{8}, y = \frac{1}{8} \left(2 \sin \frac{\pi}{4} - 2 \cos \frac{\pi}{4} \right) + e^{-2\left(\frac{\pi}{8}\right)}$$

$$y = 0 + e^{-\frac{\pi}{4}}$$

5. For the function

$$f(x) = \sin x + 3x - \frac{2}{\pi}(x^2 + x), \text{ where } x \in \left[0, \frac{\pi}{2}\right],$$

consider the following two statements :

(I) f is increasing in $\left(0, \frac{\pi}{2}\right)$.

(II) f' is decreasing in $\left(0, \frac{\pi}{2}\right)$.

Between the above two statements,

- (1) only (I) is true.
 (2) only (II) is true.
 (3) neither (I) nor (II) is true.
 (4) both (I) and (II) are true.

Ans. (4)

Sol. $f(x) = \sin x + 3x - \frac{2}{\pi}(x^2 + x) \quad x \in \left[0, \frac{\pi}{2}\right]$

$f'(x) = \cos x + 3 - \frac{2}{\pi}(2x + 1) > 0 \quad f(x) \uparrow$

$f'(x) = -\sin x + 0 - \frac{\pi}{2} (2)$

$= -\sin x - \frac{4}{\pi} < 0 \quad f'(x) \downarrow$

$0 < x < \frac{\pi}{2}$

$\Rightarrow -\frac{2}{\pi} \left(\begin{matrix} 0 < 2x < \pi \\ +1 & +1 & +1 \end{matrix} \right)$

$-\frac{2}{\pi} > -\frac{2}{\pi} (2x + 1) > -\frac{2}{\pi} (\pi + 1)$

$3 - \frac{2}{\pi} > 3 - \frac{2}{\pi} (2x + 1) > 3 - \frac{2}{\pi} (\pi + 1)$

6. If the system of equations

$11x + y + \lambda z = -5$

$2x + 3y + 5z = 3$

$8x - 19y - 39z = \mu$

has infinitely many solutions, then $\lambda^4 - \mu$ is equal to :

(1) 49

(2) 45

(3) 47

(4) 51

Ans. (3)

Sol. $11x + y + \lambda z = -5$

$2x + 3y + 5z = 3$

$8x - 19y - 39z = \mu$

for infinite sol.

$D = \begin{vmatrix} 11 & 1 & \lambda \\ 2 & 3 & 5 \\ 8 & -19 & -39 \end{vmatrix} = 0$

$\Rightarrow 11(-117 + 95) - 1(-78 - 40) + \lambda(-38 - 24)$

$\Rightarrow 11(-22) + 118 - \lambda(62) = 0$

$\Rightarrow 62\lambda = 118 - 242$

$\Rightarrow \lambda = \frac{-124}{62} = -2$

$D_1 = \begin{vmatrix} -5 & 1 & -2 \\ 3 & 3 & 5 \\ \mu & -19 & -39 \end{vmatrix} = 0$

$\Rightarrow -5(-117 + 95) - 1(-117 - 5\mu) - 2(-57 - 3\mu) = 0$

$\Rightarrow -5(-22) + 117 + 5\mu + 114 + 6\mu = 0$

$\Rightarrow 11\mu = -110 - 231 = -341$

$\Rightarrow \mu = -31$

$\lambda^4 - \mu = (-2)^4 - (-31) = 16 + 31 = 47$

7. Let $A = \{1, 3, 7, 9, 11\}$ and $B = \{2, 4, 5, 7, 8, 10, 12\}$.

Then the total number of one-one maps $f: A \rightarrow B$, such that $f(1) + f(3) = 14$, is :

(1) 180

(2) 120

(3) 480

(4) 240

Ans. (4)

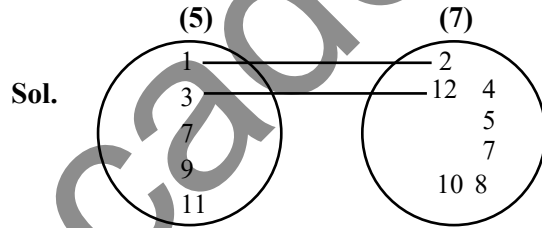

$A = \{1, 3, 7, 9, 11\}$

$B = \{2, 4, 5, 7, 8, 10, 12\}$

$f(1) + f(3) = 14$

(i) $2 + 12$

(ii) $4 + 10$

$2 \times (2 \times 5 \times 4 \times 3) = 240$

8. If the function $f(x) = \frac{\sin 3x + \alpha \sin x - \beta \cos 3x}{x^3}$,

$x \in \mathbb{R}$, is continuous at $x = 0$, then $f(0)$ is equal to :

(1) 2

(2) -2

(3) 4

(4) -4

Ans. (4)

Sol. $f(x) = \frac{\sin 3x + \alpha \sin x - \beta \cos 3x}{x^3}$

is continuous at $x = 0$

$\lim_{x \rightarrow 0} = \frac{3x - \frac{(3x)^3}{\lfloor 3} + \dots + \alpha \left(x - \frac{x^3}{\lfloor 3} \dots \right) - \beta \left(1 - \frac{(3x)^2}{\lfloor 2} \dots \right)}{x^3} = f(0)$

$$\lim_{x \rightarrow 0} \frac{-\beta + x(3 + \alpha) + \frac{9\beta x^2}{2} + \left(\frac{-27}{3} - \frac{\alpha}{3}\right)x^3 \dots}{x^3} = f(0)$$

for exist

$$\beta = 0, 3 + \alpha = 0, -\frac{27}{3} - \frac{\alpha}{3} = f(0)$$

$$\alpha = -3, -\frac{27}{6} - \frac{(-3)}{6} = f(0)$$

$$f(0) = \frac{-27 + 3}{6} = -4$$

9. The integral $\int_0^{\pi/4} \frac{136 \sin x}{3 \sin x + 5 \cos x} dx$ is equal to :

- (1) $3\pi - 50 \log_e 2 + 20 \log_e 5$
- (2) $3\pi - 25 \log_e 2 + 10 \log_e 5$
- (3) $3\pi - 10 \log_e (2\sqrt{2}) + 10 \log_e 5$
- (4) $3\pi - 30 \log_e 2 + 20 \log_e 5$

Ans. (1)

Sol. $I = \int_0^{\pi/4} \frac{136 \sin x}{3 \sin x + 5 \cos x} dx$

$$136 \sin x = A(3 \sin x + 5 \cos x) + B(3 \cos x - 5 \sin x)$$

$$136 = 3A - 5B \quad \dots(1)$$

$$0 = 5A + 3B \quad \dots(2)$$

$$3B = -5A \Rightarrow B = -\frac{5}{3}A$$

$$136 = 3A - 5\left(-\frac{5}{3}A\right)$$

$$136 = 3A + \frac{25}{3}A$$

$$136 = \frac{34A}{3}$$

$$\Rightarrow A = \frac{136 \times 3}{34} = 12$$

$$B = \frac{-5}{3}(12) = -20$$

$$I = \int_0^{\pi/4} \frac{A(3 \sin x + 5 \cos x)}{3 \sin x + 5 \cos x} + \int_0^{\pi/4} \frac{B(3 \cos x - 5 \sin x)}{3 \sin x + 5 \cos x}$$

$$= A(x)_0^{\pi/4} + B[\ln(3 \sin x + 5 \cos x)]_0^{\pi/4}$$

$$= 12\left(\frac{\pi}{4}\right) - 20 \ln\left(\frac{3}{\sqrt{2}} + \frac{5}{\sqrt{2}}\right) - \ln(0 + 5)$$

$$= 3\pi - 20 \ln 4\sqrt{2} + 20 \ln 5$$

$$= 3\pi - 20 \times \frac{5}{2} \ln 2 + 20 \ln 5$$

$$= 3\pi - 50 \ln 2 + 20 \ln 5$$

10. The coefficients a, b, c in the quadratic equation

$$ax^2 + bx + c = 0$$

are chosen from the set {1, 2, 3, 4, 5, 6, 7, 8}. The probability of this

equation having repeated roots is :

$$(1) \frac{3}{256} \quad (2) \frac{1}{128}$$

$$(3) \frac{1}{64} \quad (4) \frac{3}{128}$$

Ans. (3)

Sol. $ax^2 + bx + c = 0$

$$a, b, c \in \{1, 2, 3, 4, 5, 6, 7, 8\}$$

$$\text{Repeated roots } D = 0$$

$$\Rightarrow b^2 - 4ac = 0 \Rightarrow b^2 = 4ac$$

$$\text{Prob} = \frac{8}{8 \times 8 \times 8} = \frac{1}{64}$$

$$\Rightarrow (a, b, c)$$

$$(1, 2, 1); (2, 4, 2); (1, 4, 4); (4, 4, 1); (3, 6, 3);$$

$$(2, 8, 8); (8, 8, 2); (4, 8, 4)$$

8 case

11. Let A and B be two square matrices of order 3 such that $|A| = 3$ and $|B| = 2$.

Then $|A^T A(\text{adj}(2A))^{-1} (\text{adj}(4B))(\text{adj}(AB))^{-1} AA^T|$ is equal to :

- (1) 64 (2) 81
(3) 32 (4) 108

Ans. (1)

Sol. $|A| = 3, |B| = 2$
 $|A^T A(\text{adj}(2A))^{-1} (\text{adj}(4B)) (\text{adj}(AB))^{-1} AA^T|$
 $= 3 \times 3 \times |(\text{adj}(2A))^{-1}| \times |\text{adj}(4B)| \times |(\text{adj}(AB))^{-1}| \times 3 \times 3$

$$\begin{aligned} & \downarrow \qquad \qquad \downarrow \qquad \qquad \downarrow \\ & \frac{1}{|\text{adj}(2A)|} \qquad 2^{12 \times 2} \qquad \frac{1}{|\text{adj}(AB)|} \\ & = \frac{1}{2^6 |\text{adj}A|} \qquad \qquad \qquad = \frac{1}{|\text{adj}B \cdot \text{adj}A|} \\ & = \frac{1}{2^6 \cdot 3^2} \qquad \qquad \qquad = \frac{1}{2^2 \cdot 3^2} \end{aligned}$$

$$= 3^4 \cdot \frac{1}{2^6 \cdot 3^2} \cdot 2^{12} \cdot 2^2 \cdot \frac{1}{2^2 \cdot 3^2} = 64$$

12. Let a circle C of radius 1 and closer to the origin be such that the lines passing through the point (3, 2) and parallel to the coordinate axes touch it. Then the shortest distance of the circle C from the point (5, 5) is :

- (1) $2\sqrt{2}$ (2) 5
(3) $4\sqrt{2}$ (4) 4

Ans. (4)

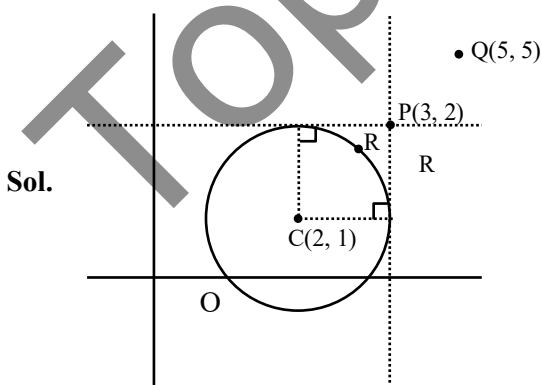

Coordinates of the centre will be (2, 1)

Equation of circle will be

$$(x - 2)^2 + (y - 1)^2 = 1$$

$$QC = \sqrt{(5-2)^2 + (5-1)^2}$$

$$QC = 5$$

shortest distance

$$= RQ = CQ - CR$$

$$= 5 - 1$$

$$= 4$$

13. Let the line $2x + 3y - k = 0, k > 0$, intersect the x-axis and y-axis at the points A and B, respectively. If the equation of the circle having the line segment AB as a diameter is $x^2 + y^2 - 3x - 2y = 0$ and the length of the latus rectum of the ellipse

$$x^2 + 9y^2 = k^2 \text{ is } \frac{m}{n}, \text{ where } m \text{ and } n \text{ are coprime,}$$

then $2m + n$ is equal to

- (1) 10 (2) 11
(3) 13 (4) 12

Ans. (2)

Sol. Centre of the circle = $\left(\frac{3}{2}, 1\right)$

$$\text{Equation of diameter} = 2x + 3y - k = 0$$

$$2\left(\frac{3}{2}\right) + 3(1) - k = 0$$

$$\Rightarrow k = 6$$

Now, Equation of ellipse becomes

$$x^2 + 9y^2 = 36$$

$$\frac{x^2}{6^2} + \frac{y^2}{2^2} = 1$$

$$\text{length of LR} = \frac{2b^2}{a} = \frac{2 \cdot 2^2}{6} = \frac{8}{6} = \frac{4}{3} = \frac{m}{n}$$

$$\therefore 2m + n = 2(4) + 3 = 11$$

14. Consider the following two statements :

Statement I : For any two non-zero complex numbers z_1, z_2

$$\left(|z_1| + |z_2| \right) \left| \frac{z_1}{|z_1|} + \frac{z_2}{|z_2|} \right| \leq 2(|z_1| + |z_2|) \text{ and}$$

Statement II : If x, y, z are three distinct complex numbers and a, b, c are three positive real numbers

such that $\frac{a}{|y-z|} = \frac{b}{|z-x|} = \frac{c}{|x-y|}$, then

$$\frac{a^2}{y-z} + \frac{b^2}{z-x} + \frac{c^2}{x-y} = 1.$$

Between the above two statements,

- (1) both Statement I and Statement II are incorrect.
- (2) Statement I is incorrect but Statement II is correct.
- (3) Statement I is correct but Statement II is incorrect.
- (4) both Statement I and Statement II are correct.

Ans. (3)

Sol. Statement I :

$$\left(|z_1| + |z_2| \right) \left| \frac{z_1}{|z_1|} + \frac{z_2}{|z_2|} \right|$$

$$\text{Since } \left| \frac{z_1}{|z_1|} + \frac{z_2}{|z_2|} \right| \leq \left| \frac{z_1}{|z_1|} \right| + \left| \frac{z_2}{|z_2|} \right|$$

$$\left| \frac{z_1}{|z_1|} + \frac{z_2}{|z_2|} \right| \leq \frac{|z_1|}{|z_1|} + \frac{|z_2|}{|z_2|}$$

$$\left| \frac{z_1}{|z_1|} + \frac{z_2}{|z_2|} \right| \leq 2$$

$$\left(|z_1| + |z_2| \right) \left(\left| \frac{z_1}{|z_1|} + \frac{z_2}{|z_2|} \right| \right) \leq 2(|z_1| + |z_2|)$$

\therefore statement I is correct

For Statement II :

$$\frac{a}{|y-z|} = \frac{b}{|z-x|} = \frac{c}{|x-y|}$$

$$\frac{a^2}{|y-z|^2} = \frac{b^2}{|z-x|^2} = \frac{c^2}{|x-y|^2} = \lambda$$

$$a^2 = \lambda(|y-z|^2) = \lambda(y-z)(\bar{y}-\bar{z})$$

$$b^2 = \lambda(z-x)(\bar{z}-\bar{x}) \text{ and } c^2 = \lambda(x-y)(\bar{x}-\bar{y})$$

$$\frac{a^2}{y-z} + \frac{b^2}{z-x} + \frac{c^2}{x-y} = \lambda(\bar{y}-\bar{z} + \bar{z}-\bar{x} + \bar{x}-\bar{y}) = 0$$

Statement II is false

15. Suppose $\theta \in \left[0, \frac{\pi}{4} \right]$ is a solution of $4 \cos\theta - 3 \sin\theta = 1$.

Then $\cos\theta$ is equal to :

$$(1) \frac{4}{3\sqrt{6}-2} \quad (2) \frac{6-\sqrt{6}}{3\sqrt{6}-2}$$

$$(3) \frac{6+\sqrt{6}}{3\sqrt{6}+2} \quad (4) \frac{4}{3\sqrt{6}+2}$$

Ans. (1)

$$\text{Sol. } 4 \left(\frac{1 - \tan^2 \theta / 2}{1 + \tan^2 \theta / 2} \right) - 3 \left(\frac{2 \tan \frac{\theta}{2}}{1 + \tan^2 \frac{\theta}{2}} \right) = 1$$

$$\text{let } \tan \frac{\theta}{2} = t$$

$$\frac{4 - 4t^2 - 6t}{1 + t^2} = 1$$

$$4 - 4t^2 - 6t = 1 + t^2$$

$$\Rightarrow 5t^2 + 6t - 3 = 0$$

$$\Rightarrow t = \frac{-6 \pm \sqrt{36 - 4(5)(-3)}}{2(5)}$$

$$= \frac{-6 \pm \sqrt{96}}{10}$$

$$= \frac{-6 \pm 4\sqrt{6}}{10}$$

$$t = \frac{-3 + 2\sqrt{6}}{5}$$

$$\cos \theta = \frac{1-t^2}{1+t^2} = \frac{1 - \left(\frac{2\sqrt{6}-3}{5}\right)^2}{1 + \left(\frac{2\sqrt{6}-3}{5}\right)^2} = \frac{1 - \left(\frac{24+9-12\sqrt{6}}{25}\right)}{1 + \left(\frac{24+9-12\sqrt{6}}{25}\right)}$$

$$= \frac{25-33+12\sqrt{6}}{25+33-12\sqrt{6}} = \frac{12\sqrt{6}-8}{58-12\sqrt{6}} = \frac{6\sqrt{6}-4}{29-6\sqrt{6}} \times \frac{29+6\sqrt{6}}{29+6\sqrt{6}}$$

$$= \frac{100+150\sqrt{6}}{625} = \frac{4+6\sqrt{6}}{25} \times \frac{4-6\sqrt{6}}{4-6\sqrt{6}}$$

$$= \frac{-200}{25(4-6\sqrt{6})} = \frac{-8}{4-6\sqrt{6}} = \frac{4}{3\sqrt{6}-2}$$

16. If $\frac{1}{\sqrt{1}+\sqrt{2}} + \frac{1}{\sqrt{2}+\sqrt{3}} + \dots + \frac{1}{\sqrt{99}+\sqrt{100}} = m$ and

$$\frac{1}{1 \cdot 2} + \frac{1}{2 \cdot 3} + \dots + \frac{1}{99 \cdot 100} = n, \text{ then the point } (m, n)$$

lies on the line

(1) $11(x-1) - 100(y-2) = 0$

(2) $11(x-2) - 100(y-1) = 0$

(3) $11(x-1) - 100y = 0$

(4) $11x - 100y = 0$

Ans. (4)

Sol. $\frac{1}{\sqrt{1}+\sqrt{2}} + \frac{1}{\sqrt{2}+\sqrt{3}} + \dots + \frac{1}{\sqrt{99}+\sqrt{100}} = m$

$$\frac{\sqrt{1}-\sqrt{2}}{-1} + \frac{\sqrt{2}-\sqrt{3}}{-1} \dots \frac{\sqrt{99}-\sqrt{100}}{-1} = m$$

$$\sqrt{100} - 1 = m \Rightarrow m = 9$$

$$\frac{1}{1 \cdot 2} + \frac{1}{2 \cdot 3} + \dots + \frac{1}{99 \cdot 100} = n$$

$$\frac{1}{1} - \frac{1}{2} + \frac{1}{2} - \frac{1}{3} \dots - \frac{1}{99} - \frac{1}{100} = n$$

$$1 - \frac{1}{100} = n$$

$$\frac{99}{100} = n$$

$$(m, n) = \left(9, \frac{99}{100}\right)$$

$$\Rightarrow 11(9) - 100\left(\frac{99}{100}\right)$$

$$= 99 - 99 = 0$$

Ans. option (4). $11x - 100y = 0$

17. Let $f(x) = x^5 + 2x^3 + 3x + 1$, $x \in \mathbb{R}$, and $g(x)$ be a function such that $g(f(x)) = x$ for all $x \in \mathbb{R}$. Then

$\frac{g(7)}{g'(7)}$ is equal to :

(1) 7 (2) 42

(3) 1 (4) 14

Ans. (4)

Sol. $f(x) = x^5 + 2x^3 + 3x + 1$

$$f'(x) = 5x^4 + 6x^2 + 3$$

$$f'(1) = 5 + 6 + 3 = 14$$

$$g(f(x)) = x$$

$$g'(f(x))f'(x) = 1$$

for $f(x) = 7$

$$\Rightarrow x^5 + 2x^3 + 3x + 1 = 7$$

$$\Rightarrow x = 1$$

$$g'(7) f'(1) = 1 \Rightarrow g'(7) = \frac{1}{f'(1)} = \frac{1}{14}$$

$$x = 1, f(x) = 7 \Rightarrow g(7) = 1$$

$$\frac{g(7)}{g'(7)} = \frac{1}{1/14} = 14$$

18. If A(1, -1, 2), B(5, 7, -6), C(3, 4, -10) and D(-1, -4, -2) are the vertices of a quadrilateral ABCD, then its area is :

(1) $12\sqrt{29}$ (2) $24\sqrt{29}$

(3) $24\sqrt{7}$ (4) $48\sqrt{7}$

Ans. (1)

- Sol.** A(1, -1, 2)
 B(5, 7, -6)
 C(3, 4, -10)
 D(-1, -4, -2)

$$\text{Area} = \frac{1}{2} |\vec{AC} \times \vec{BD}| = \frac{1}{2} |(2\hat{i} + 5\hat{j} - 12\hat{k}) \times (6\hat{i} + 11\hat{j} - 4\hat{k})|$$

$$= \frac{1}{2} |112\hat{i} - 64\hat{j} - 8\hat{k}|$$

$$= 4 |14\hat{i} - 8\hat{j} - \hat{k}|$$

$$= 4\sqrt{196 + 64 + 1}$$

$$= 4\sqrt{261}$$

$$= 12\sqrt{29}$$

19. The value of $\int_{-\pi}^{\pi} \frac{2y(1 + \sin y)}{1 + \cos^2 y} dy$ is :

(1) π^2 (2) $\frac{\pi^2}{2}$

(3) $\frac{\pi}{2}$ (4) $2\pi^2$

Ans. (1)

Sol. $\int_{-\pi}^{\pi} \frac{2y(1 + \sin y)}{1 + \cos^2 y} dy$

$$= \int_{-\pi}^{\pi} \frac{2y}{1 + \cos^2 y} dy + \int_{-\pi}^{\pi} \frac{2y \sin y}{1 + \cos^2 y} dy$$

(Odd) (Even)

$$= 0 + 2.2 \int_0^{\pi} y \left(\frac{\sin y}{1 + \cos^2 y} \right) dy$$

$$I = 4 \int_0^{\pi} \frac{y \sin y}{1 + \cos^2 y} dy$$

$$I = 4 \int_0^{\pi} \frac{(\pi - y) \sin y}{1 + \cos^2 y} dy$$

$$2I = 4 \int_0^{\pi} \frac{\pi \sin y}{1 + \cos^2 y} dy$$

$$I = 2\pi \int_0^{\pi} \frac{\sin y}{1 + \cos^2 y} dy$$

$$= 2\pi \left(-\tan^{-1}(\cos y) \right)_0^{\pi}$$

$$= -2\pi \left[\left(-\frac{\pi}{4} \right) - \left(\frac{\pi}{4} \right) \right]$$

$$= -2\pi \left[-\frac{2\pi}{4} \right] = \pi^2$$

20. If the line $\frac{2-x}{3} = \frac{3y-2}{4\lambda+1} = 4-z$ makes a right angle with the line $\frac{x+3}{3\mu} = \frac{1-2y}{6} = \frac{5-z}{7}$, then

$4\lambda + 9\mu$ is equal to :

(1) 13 (2) 4

(3) 5 (4) 6

Ans. (4)

Sol. $\frac{2-x}{3} = \frac{3y-2}{4\lambda+1} = 4-z \dots(1)$

$$\frac{x-2}{(-3)} = \frac{y-\frac{2}{3}}{\left(\frac{4\lambda+1}{3} \right)} = \frac{z-4}{(-1)}$$

$$\frac{x+3}{3\mu} = \frac{1-2y}{6} = \frac{5-z}{7} \quad \dots(2)$$

$$\frac{x+3}{3\mu} = \frac{y-\frac{1}{2}}{(-3)} = \frac{z-5}{(-7)}$$

$$\text{Right angle} \Rightarrow (-3)(3\mu) + \left(\frac{4\lambda+1}{3}\right)(-3) + (-1)(-7) = 0$$

$$\begin{aligned} -9\mu - 4\lambda - 1 + 7 &= 0 \\ 4\lambda + 9\mu &= 6 \end{aligned}$$

SECTION-B

21. From a lot of 10 items, which include 3 defective items, a sample of 5 items is drawn at random. Let the random variable X denote the number of defective items in the sample. If the variance of X is σ^2 , then $96\sigma^2$ is equal to _____.

Ans. (56)

Sol. X = denotes number of defective

x	0	1	2	3
P(x)	$\frac{7}{15}$	$\frac{5}{12}$	$\frac{5}{12}$	$\frac{1}{12}$
x_i^2	0	1	4	9
$P_i x_i^2$	0	$\frac{5}{12}$	$\frac{20}{12}$	$\frac{9}{12}$
$p_i x_i$	0	$\frac{5}{12}$	$\frac{10}{12}$	$\frac{3}{12}$

$$\mu = \sum p_i x_i = \frac{18}{12}$$

$$\sum p_i x_i^2 = \frac{34}{12}$$

$$\sigma^2 = \sum p_i x_i^2 - (\mu)^2$$

$$= \frac{34}{12} - \left(\frac{18}{12}\right)^2 = \frac{17}{6} - \frac{9}{4}$$

$$\frac{34-27}{12} = \frac{7}{12}$$

$$96\sigma^2 = 96 \times \frac{7}{12} = 56$$

22. If the constant term in the expansion of $(1+2x-3x^3)\left(\frac{3}{2}x^2-\frac{1}{3x}\right)^9$ is p, then $108p$ is equal to

to

Ans. (54)

$$\text{Sol. } (1+2x-3x^3)\left(\frac{3}{2}x^2-\frac{1}{3x}\right)^9$$

$$\text{General term m } \left(\frac{3}{2}x^2-\frac{1}{3x}\right)^9$$

$$= {}^9C_r \cdot \frac{3^{9-2r}}{2^{9-r}} (-1)^r \cdot x^{18-3r}$$

$$\text{Put } r = 6 \text{ to get coeff. of } x^0 = {}^9C_6 \cdot \frac{1}{6^3} \cdot x^0 = \frac{7}{18} x^0$$

$$\text{Put } r = 7 \text{ to get coeff. of } x^{-3} = {}^9C_7 \cdot \frac{3^{-5}}{2^2} (-1)^7 \cdot x^{-3}$$

$$= -{}^9C_7 \cdot \frac{1}{3^5 \cdot 2^2} \cdot x^{-3} = -\frac{1}{27} x^{-3}$$

$$(1+2x-3x^3)\left(\frac{7}{18}x^0-\frac{1}{27}x^{-3}\right)$$

$$\frac{7}{18} + \frac{3}{27} = \frac{7}{18} + \frac{1}{9} = \frac{7+2}{18} = \frac{9}{18} = \frac{1}{2}$$

$$\therefore 108 \cdot \frac{1}{2} = 54$$

23. The area of the region enclosed by the parabolas $y = x^2 - 5x$ and $y = 7x - x^2$ is _____.

Ans. (72)

NTA Ans. (198)

Sol. $y = x^2 - 5x$ and $y = 7x - x^2$

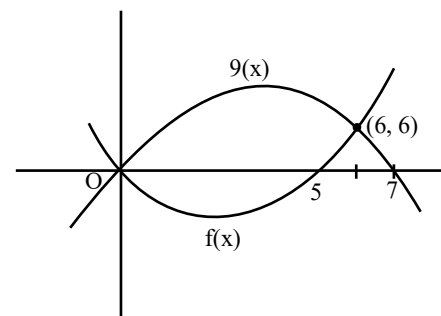

$$\int_0^6 (g(x) - f(x)) dx$$

$$\int_0^6 ((7x - x^2) - (x^2 - 5x)) dx$$

$$\int_0^6 (12x - 2x^2) dx = \left[12 \frac{x^2}{2} - \frac{2x^3}{3} \right]_0^6$$

$$\Rightarrow 6(6)^2 - \frac{2}{3}(6)^3$$

$$= 216 - 144 = 72 \text{ unit}^2$$

24. The number of ways of getting a sum 16 on throwing a dice four times is _____.

Ans. (125)

Sol. $(x^1 + x^2 + \dots + x^6)^4$

$$x^4 \left(\frac{1-x^6}{1-x} \right)^4$$

$$x^4 \cdot (1-x)^6 \cdot (1-x)^{-4}$$

$$x^4 [1 - 4x^6 + 6x^{12} \dots] [(1-x)^{-4}]$$

$$(x^4 - 4x^{10} + 6x^{16} \dots) (1-x)^{-4}$$

$$(x^4 - 4x^{10} + 6x^{16}) (1 + {}^{15}C_{12}x^{12} + {}^9C_6x^6 \dots)$$

$$({}^{15}C_{12} - 4 \cdot {}^9C_6 + 6)x^{16}$$

$$({}^{15}C_3 - 4 \cdot {}^9C_6 + 6)$$

$$= 35 \times 13 - 6 \times 8 \times 7 + 6$$

$$= 455 - 336 + 6$$

$$= 125$$

25. If $S = \{a \in \mathbb{R} : |2a - 1| = 3[a] + 2\{a\}\}$, where $[t]$ denotes the greatest integer less than or equal to t and $\{t\}$ represents the fractional part of t , then

$72 \sum_{a \in S} a$ is equal to _____.

Ans. (18)

Sol. $|2a - 1| = 3[a] + 2\{a\}$

$$|2a - 1| = [a] + 2a$$

Case-1 : $a > \frac{1}{2}$

$$2a - 1 = [a] + 2a$$

$$[a] = -1 \quad \therefore a \in [-1, 0) \text{ Reject}$$

Case-2 : $a < \frac{1}{2}$

$$-2a + 1 = [a] + 2a$$

$$a = I + f$$

$$-2(I + f) + 1 = I + 2I + 2f$$

$$I = 0, f = \frac{1}{4} \quad \therefore a = \frac{1}{4}$$

$$\text{Hence } a = \frac{1}{4}$$

$$72 \sum_{a \in S} a = 72 \times \frac{1}{4} = 18$$

26. Let f be a differentiable function in the interval

$$(0, \infty) \text{ such that } f(1) = 1 \text{ and } \lim_{t \rightarrow x} \frac{t^2 f(x) - x^2 f(t)}{t - x} = 1$$

for each $x > 0$. Then $2f(2) + 3f(3)$ is equal to

_____.

Ans. (24)

Sol. $\lim_{t \rightarrow x} \frac{t^2 f(x) - x^2 f(t)}{t - x} = 1$

$$\lim_{t \rightarrow x} \frac{2t \cdot f(x) - x^2 f'(x)}{1} = 1$$

$$2x \cdot f(x) - x^2 f'(x) = 1$$

$$\frac{dy}{dx} - \frac{2}{x} \cdot y = \frac{-1}{x^2}$$

$$\text{I.f.} = e^{\int -\frac{2}{x} dx} = \frac{1}{x^2}$$

$$\therefore \frac{y}{x^2} = \int -\frac{1}{x^4} dx + C$$

$$\frac{y}{x^2} = \frac{1}{3x^3} + C$$

$$\text{Put } f(1) = 1$$

$$C = \frac{2}{3}$$

$$y = \frac{1}{3x} + \frac{2x^2}{3}$$

$$y = \frac{2x^3 + 1}{3x}$$

$$f(2) = \frac{17}{6}$$

$$f(3) = \frac{55}{9}$$

$$2f(2) + 3f(3) = \frac{17}{3} + \frac{55}{3} = \frac{72}{3} = 24$$

27. Let a_1, a_2, a_3, \dots be in an arithmetic progression of positive terms.

$$\text{Let } A_k = a_1^2 - a_2^2 + a_3^2 - a_4^2 + \dots + a_{2k-1}^2 - a_{2k}^2.$$

If $A_3 = -153$, $A_5 = -435$ and $a_1^2 + a_2^2 + a_3^2 = 66$, then $a_{17} - A_7$ is equal to _____.

Ans. (910)

- Sol.** $d \rightarrow$ common diff.

$$A_k = -kd[2a + (2k - 1)d]$$

$$A_3 = -153$$

$$\Rightarrow 153 = 13d[2a + 5d]$$

$$51 = d[2a + 5d] \quad \dots(1)$$

$$A_5 = -435$$

$$435 = 5d[2a + 9d]$$

$$87 = d[2a + 9d]$$

$$(2) - (1)$$

$$36 = 4d^2$$

$$d = 3, a = 1$$

$$a_{17} - A_7 = 49 - [-7.3[2 + 39]] = 910$$

28. Let $\vec{a} = \hat{i} - 3\hat{j} + 7\hat{k}$, $\vec{b} = 2\hat{i} - \hat{j} + \hat{k}$ and \vec{c} be a vector such that $(\vec{a} + 2\vec{b}) \times \vec{c} = 3(\vec{c} \times \vec{a})$. If $\vec{a} \cdot \vec{c} = 130$, then $\vec{b} \cdot \vec{c}$ is equal to _____.

Ans. (30)

Sol. $(\vec{a} + 2\vec{b}) \times \vec{c} = 3(\vec{c} \times \vec{a})$

$$(2\vec{b} + 4\vec{a}) \times \vec{c} = 0$$

$$\vec{c} = \lambda(4\vec{a} + 2\vec{b}) = \lambda(8\hat{i} - 14\hat{j} + 30\hat{k})$$

$$\vec{a} \cdot \vec{c} = 130$$

$$8\lambda + 42\lambda + 210\lambda = 130$$

$$\lambda = \frac{1}{2}$$

$$\vec{c} = 4\hat{i} - 7\hat{j} + 15\hat{k}$$

$$\vec{b} \cdot \vec{c} = 8 + 7 + 15 = 30$$

29. The number of distinct real roots of the equation $|x| |x + 2| - 5|x + 1| - 1 = 0$ is _____.

Ans. (3)



Sol.

Case-1

$$x \geq 0$$

$$x^2 + 2x - 5x - 5 - 1 = 0$$

$$x^2 - 3x - 6 = 0$$

$$x = \frac{3 \pm \sqrt{9 + 24}}{2} = \frac{3 \pm \sqrt{33}}{2}$$

One positive root

Case-2

$$-1 \leq x < 0$$

$$-x^2 - 2x - 5x - 5 - 1 = 0$$

$$x^2 + 7x + 6 = 0$$

$$(x + 6)(x + 1) = 0$$

$$x = -1$$

one root in range

Case-3

$$-2 \leq x < -1$$

$$x^2 - 2x + 5x + 5 - 1 = 0$$

$$x^2 - 3x - 4 = 0$$

$$(x - 4)(x + 1) = 0$$

No root in range

Case-4

$$x < -2$$

$$x^2 + 7x + 4 = 0$$

$$x = \frac{-7 \pm \sqrt{49 - 16}}{2} = \frac{7 \pm \sqrt{33}}{2}$$

one root in range

Total number of distinct roots are 3

30. Suppose AB is a focal chord of the parabola $y^2 = 12x$ of length l and slope $m < \sqrt{3}$. If the distance of the chord AB from the origin is d , then ld^2 is equal to _____.

Ans. (108)

Sol.

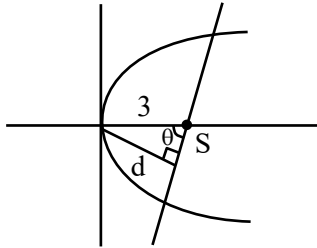

$$l = 4a \operatorname{cosec}^2 \theta$$

$$l = 12 \times \frac{9}{d^2}$$

$$ld^2 = 108$$

PHYSICS

TEST PAPER WITH SOLUTION

SECTION-A

31. Light emerges out of a convex lens when a source of light kept at its focus. The shape of wavefront of the light is:

- (1) Both spherical and cylindrical
- (2) Cylindrical
- (3) Spherical
- (4) Plane

Ans. (4)

Sol. Light emerges parallel
 \therefore planor wavefront

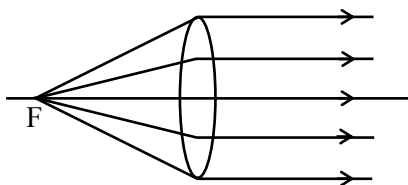

32. Following gates section is connected in a complete suitable circuit.

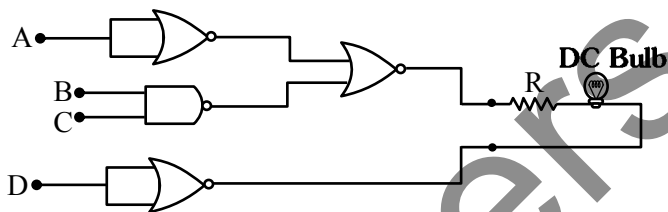

For which of the following combination, bulb will glow (ON):

- (1) A = 0, B = 1, C = 1, D = 1
- (2) A = 1, B = 0, C = 0, D = 0
- (3) A = 0, B = 0, C = 0, D = 1
- (4) A = 1, B = 1, C = 1, D = 0

Ans. (2)

Sol. Bulb will glow if bulb have potential drop on it. One end of bulb must be at high (1) and other must be at low (0).

Option (2) satisfy this condition

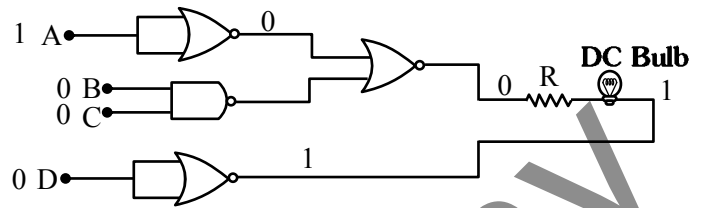

33. If G be the gravitational constant and u be the energy density then which of the following quantity have the dimension as that the \sqrt{uG} :

- (1) Pressure gradient per unit mass
- (2) Force per unit mass
- (3) Gravitational potential
- (4) Energy per unit mass

Ans. (2)

Sol. $[uG] = [(M^1L^{-1}T^{-2}) (M^{-1}L^3T^{-2})]$

$$[uG] = [M^0L^2T^{-4}]$$

$$[\sqrt{uG}] = [L^1T^{-2}]$$

Option (2) is correct

34. Given below are two statements :

Statement-I: When a capillary tube is dipped into a liquid, the liquid neither rises nor falls in the capillary. The contact angle may be 0° .

Statement-II: The contact angle between a solid and a liquid is a property of the material of the solid and liquid as well :

In the light of above statement, choose the **correct** answer from the options given below.

- (1) **Statement-I** is false but **Statement-II** is true.
- (2) Both **Statement-I** and **Statement-II** are true.
- (3) Both **Statement-I** and **Statement-II** are false.
- (4) **Statement-I** is true and **Statement-II** is false.

Ans. (1)

Sol. Capillary rise

$$h = \frac{2T \cos \theta}{\rho g r};$$

If $\theta = 0^\circ$ then rise is non-zero

\therefore Statement-1 is incorrect.

Option(1) is correct

35. Given below are two statements:

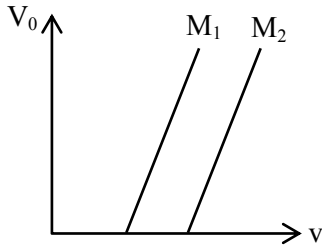

Statement-I: Figure shows the variation of stopping potential with frequency (ν) for the two photosensitive materials M_1 and M_2 . The slope

gives value of $\frac{h}{e}$, where h is Planck's constant, e is the charge of electron.

Statement-II: M_2 will emit photoelectrons of greater kinetic energy for the incident radiation having same frequency.

In the light of the above statements, choose the most appropriate answer from the options given below.

- (1) **Statement-I** is correct and **Statement-II** is incorrect.
 (2) **Statement-I** is incorrect but **Statement-II** is correct.
 (3) Both **Statement-I** and **Statement-II** are incorrect.
 (4) Both **Statement-I** and **Statement-II** are correct.

Ans. (1)

Sol. $eV_0 = h\nu - \phi$

$$V_0 = \frac{h}{e} \nu - \frac{\phi}{e}$$

M_2 material has higher work function, so statement-(II) is incorrect.

Option (1) is correct.

36. The angle between vector \vec{Q} and the resultant of $(2\vec{Q} + 2\vec{P})$ and $(2\vec{Q} - 2\vec{P})$ is:

- (1) 0°
 (2) $\tan^{-1} \left(\frac{2\vec{Q} - 2\vec{P}}{2\vec{Q} + 2\vec{P}} \right)$
 (3) $\tan^{-1} \left(\frac{P}{Q} \right)$
 (4) $\tan^{-1} \left(\frac{2Q}{P} \right)$

Ans. (1)

Sol. $\vec{R} = (2\vec{Q} + 2\vec{P}) + (2\vec{Q} - 2\vec{P})$

$$\vec{R} = 4\vec{Q}$$

Angle between \vec{Q} and \vec{R} is zero

Option (1) is correct

37. In hydrogen like system the ratio of coulombian force and gravitational force between an electron and a proton is in the order of:

- (1) 10^{39} (2) 10^{19}
 (3) 10^{29} (4) 10^{36}

Ans. (1)

Sol. $F_e = \frac{kQ_1Q_2}{r^2} = \frac{9 \times 10^9 \times 1.6 \times 10^{-19} \times 1.6 \times 10^{-19}}{r^2}$

$$F_g = \frac{Gm_1m_2}{r^2} = \frac{6.67 \times 10^{-11} \times 9.1 \times 10^{-31} \times 1.6 \times 10^{-27}}{r^2}$$

$$\frac{F_e}{F_g} \cong 0.23 \times 10^{40} \cong 2.3 \times 10^{39}$$

Option (1)

38. In a co-axial straight cable, the central conductor and the outer conductor carry equal currents in opposite directions. The magnetic field is zero.

- (1) inside the outer conductor
 (2) in between the two conductors
 (3) outside the cable
 (4) inside the inner conductor

Ans. (3)

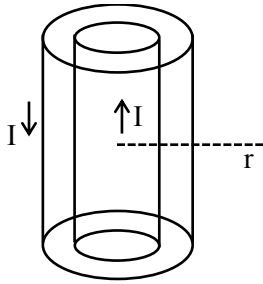

Sol.

$$\oint \vec{B} \cdot d\vec{\ell} = \mu_0 i_{enc} = 0$$

$\therefore B = 0$ outside the cable

39. An electron rotates in a circle around a nucleus having positive charge Ze . Correct relation between total energy (E) of electron to its potential energy (U) is:

- (1) $E = 2U$ (2) $2E = 3U$
 (3) $E = U$ (4) $2E = U$

Ans. (4)

Sol. $F = \frac{k(Ze)(e)}{r^2} = \frac{mv^2}{r}$

$$KE = \frac{1}{2}mv^2 = \frac{1}{2} \frac{K(Ze)(e)}{r}$$

$$PE = -\frac{K(Ze)(e)}{r}$$

$$TE = \frac{K(Ze)(e)}{2r} - \frac{K(Ze)(e)}{r} = \frac{-K(Ze)(e)}{2r}$$

$$TE = \frac{PE}{2}$$

$$2TE = PE$$

Option (4)

40. If the collision frequency of hydrogen molecules in a closed chamber at 27°C is Z , then the collision frequency of the same system at 127°C is :

- (1) $\frac{\sqrt{3}}{2}Z$ (2) $\frac{4}{3}Z$
 (3) $\frac{2}{\sqrt{3}}Z$ (4) $\frac{3}{4}Z$

Ans. (3)

Sol. Assuming mean free path constant.

$$f \propto v \propto \sqrt{T}$$

$$\frac{f_1}{f_2} = \sqrt{\frac{T_1}{T_2}} = \sqrt{\frac{300}{400}}$$

$$f_2 = \sqrt{\frac{4}{3}} = f_1 = \frac{2}{\sqrt{3}}Z$$

41. Ratio of radius of gyration of a hollow sphere to that of a solid cylinder of equal mass, for moment of Inertia about their diameter axis AB as shown in

figure is $\sqrt{\frac{8}{x}}$. The value of x is:

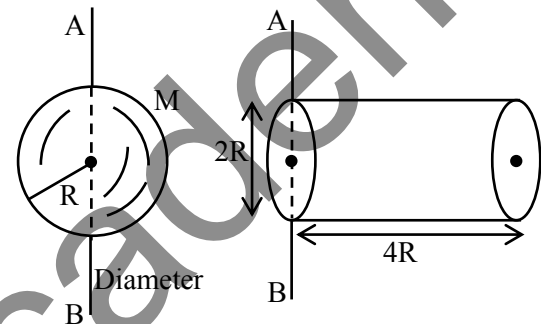

- (1) 34 (2) 17
 (3) 67 (4) 51

Ans. (3)

Sol. $I_{\text{sphere}} = \frac{2}{3}MR^2 = Mk_1^2$

$$I_{\text{cylinder}} = \frac{1}{12}M(4R)^2 + \frac{1}{4}MR^2 + M(2R)^2$$

$$= \frac{67}{12}MR^2 = Mk_2^2$$

$$\frac{k_1}{k_2} = \sqrt{\frac{2}{3} \cdot \frac{12}{67}} = \sqrt{\frac{8}{67}}$$

42. Two conducting circular loops A and B are placed in the same plane with their centres coinciding as shown in figure. The mutual inductance between them is:

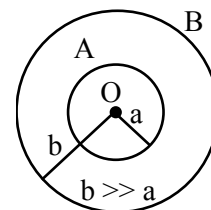

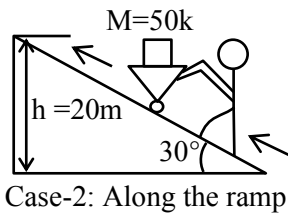
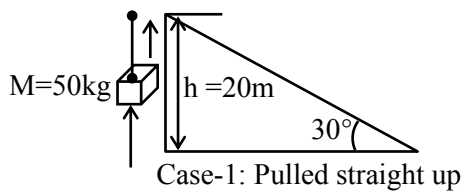

- (1) 1 : 1 (2) 2 : 1
 (3) $\sqrt{3} : 2$ (4) 1 : 2

Ans. (1)

Sol. Work done by gravity is independent of path. It depends only on vertical displacement so work done in both cases will be same.

Option (1) is correct

47. Time periods of oscillation of the same simple pendulum measured using four different measuring clocks were recorded as 4.62 s, 4.632 s, 4.6 s and 4.64 s. The arithmetic mean of these reading in correct significant figure is.

- (1) 4.623 s (2) 4.62 s
 (3) 4.6 s (4) 5 s

Ans. (3)

Sol. Sum of number by considering significant digit
 $\text{sum} = 4.6 + 4.6 + 4.6 + 4.6 = 18.4$

$$\text{Arithmetic Mean} = \frac{\text{sum}}{4} = \frac{18.4}{4} = 4.6$$

48. The heat absorbed by a system in going through the given cyclic process is :

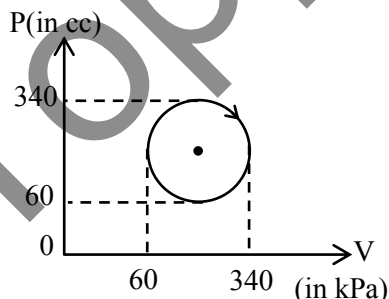

- (1) 61.6 J (2) 431.2 J
 (3) 616 J (4) 19.6 J

Ans. (1)

Sol. $\Delta U = 0$ (Cyclic process)

$$\Delta Q = W = \text{area of P-V curve.}$$

$$= \pi \times (140 \times 10^3 \text{ Pa}) \times (140 \times 10^{-6} \text{ m}^3)$$

$$\Delta Q = 61.6 \text{ J}$$

49. In the given figure $R_1 = 10\Omega$, $R_2 = 8\Omega$, $R_3 = 4\Omega$ and $R_4 = 8\Omega$. Battery is ideal with emf 12V. Equivalent resistant of the circuit and current supplied by battery are respectively.

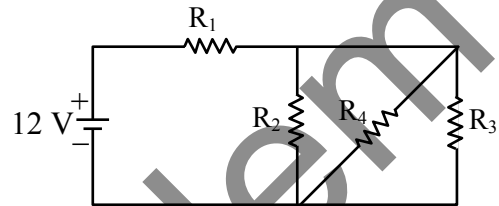

- (1) 12 Ω and 11.4 A (2) 10.5 Ω and 1.14 A
 (3) 10.5 Ω and 1 A (4) 12 Ω and 1 A

Ans. (4)

Sol. Here R_2, R_3, R_4 are in parallel

$$\frac{1}{R_{234}} = \frac{1}{R_2} + \frac{1}{R_3} + \frac{1}{R_4}$$

$$R_{234} = 2\Omega$$

R_{234} is in series with R_1 so

$$R_{eq} = R_{234} + R_1 = 2 + 10 = 12\Omega$$

$$i = \frac{12}{12} = 1\text{Amp}$$

50. An alternating voltage of amplitude 40 V and frequency 4 kHz is applied directly across the capacitor of 12 μF . The maximum displacement current between the plates of the capacitor is nearly:

- (1) 13 A (2) 8 A
 (3) 10 A (4) 12 A

Ans. (4)

Sol. Displacement current is same as conduction current in capacitor.

$$X_c = \frac{1}{\omega C} = \frac{1}{2\pi f C}$$

$$= \frac{1}{2\pi \times 4 \times 10^3 \times 12 \times 10^{-6}} = 3.317\Omega$$

$$I = \frac{V}{X_C} = \frac{40}{3.317} = 12A$$

SECTION-B

51. In Young's double slit experiment, carried out with light of wavelength 5000\AA , the distance between the slits is 0.3 mm and the screen is at 200 cm from the slits. The central maximum is at $x = 0\text{ cm}$. The value of x for third maxima is mm.

Ans. (10)

Sol.
$$\beta = \frac{\lambda D}{d} = \frac{5 \times 10^{-7} \times 2}{3 \times 10^{-4}} = \frac{10 \times 10^{-3}}{3}\text{ m}$$

For 3rd maxima $y_3 = 3\beta = 10 \times 10^{-3}\text{ m} = 10\text{ mm}$

52. A 2A current carrying straight metal wire of resistance $1\ \Omega$, resistivity $2 \times 10^{-6}\ \Omega\text{m}$, area of cross-section 10 mm^2 and mass 500 g is suspended horizontally in mid air by applying a uniform magnetic field \vec{B} . The magnitude of B is $\times 10^{-1}\text{ T}$ (given, $g = 10\text{ m/s}^2$)

Ans. (5)

Sol.
$$R = \frac{\rho \ell}{A} \Rightarrow \frac{2 \times 10^{-6} \times \ell}{10^{-5}} = 1 \Rightarrow \ell = 5$$

$mg = Bil$

$$B = \frac{mg}{i\ell} = \frac{5}{2 \times 5} = 0.5 = 5 \times 10^{-1}\text{ Tesla}$$

53. The electric field between the two parallel plates of a capacitor of $1.5\ \mu\text{F}$ capacitance drops to one third of its initial value in $6.6\ \mu\text{s}$ when the plates are connected by a thin wire. The resistance of this wire is Ω . (Given, $\log 3 = 1.1$)

Ans. (4)

Sol.
$$E = \frac{E_0}{3} \Rightarrow V = \frac{V_0}{3}$$

$$\frac{V_0}{3} = V_0 e^{-\frac{t}{\tau}}$$

$t = \tau \ln 3$

$6.6 \times 10^{-6} = R (1.5 \times 10^{-6})(1.1)$

$$R = \frac{6}{1.5} = 4\ \Omega$$

54. Three blocks M_1, M_2, M_3 having masses $4\text{ kg}, 6\text{ kg}$ and 10 kg respectively are hanging from a smooth pully using rope 1, 2 and 3 as shown in figure. The tension in the rope 1, T_1 when they are moving upward with acceleration of 2 m/s^2 is N (if $g = 10\text{ m/s}^2$)

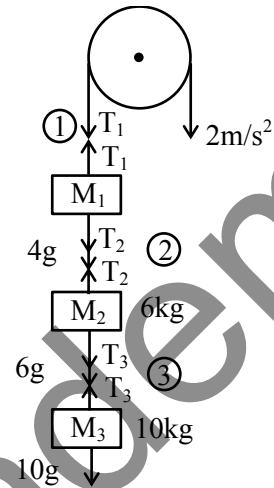

Ans. (240)

Sol. FBD of M_1 :

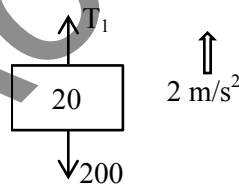

$T_1 - 200 = (4 + 6 + 10) \times 2$

$\therefore T_1 = 240$

55. The density and breaking stress of a wire are $6 \times 10^4\text{ kg/m}^3$ and $1.2 \times 10^8\text{ N/m}^2$ respectively. The wire is suspended from a rigid support on a planet where acceleration due to gravity is $\frac{1^{\text{rd}}}{3}$ of the value on the surface of earth. The maximum length of the wire with breaking is m (take, $g = 10\text{ m/s}^2$)

Ans. (600)

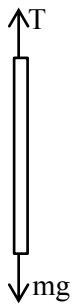

Sol.

$$T = mg$$

$$\sigma = \frac{T}{A} = \frac{mg}{A}$$

$$\frac{(\sigma A \ell)g}{A}$$

$$\Rightarrow \ell = \frac{\sigma}{\rho g} = \frac{1.2 \times 10^8 \times 3}{6 \times 10^4 \times 10} = 600$$

56. A body moves on a frictionless plane starting from rest. If S_n is distance moved between $t = n - 1$ and $t = n$ and S_{n-1} is distance moved between $t = n - 2$ and $t = n - 1$, then the ratio $\frac{S_{n-1}}{S_n}$ is $\left(1 - \frac{2}{x}\right)$ for $n = 10$. The value of x is

Ans. (19)

Sol. $S_n = \frac{1}{2} a(2n - 1) = \frac{19a}{2}$

$$S_{n-1} = \frac{1}{2} a(2n - 3) = \frac{17a}{2}$$

$$\frac{S_{n-1}}{S_n} = \frac{17}{19} = 1 - \frac{2}{x} \Rightarrow x = 19$$

57. If three helium nuclei combine to form a carbon nucleus then the energy released in this reaction is $\times 10^{-2}$ MeV. (Given $1 \text{ u} = 931 \text{ MeV}/c^2$, atomic mass of helium = 4.002603 u)

Ans. (727)

Sol. Reaction :

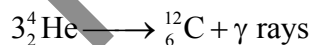

$$\text{Mass defect} = \Delta m = (3m_{\text{He}} - m_{\text{C}})$$

$$= (3 \times 4.002603 - 12) = 0.007809 \text{ u}$$

Energy released

$$= 931 \Delta m \text{ MeV}$$

$$= 7.27 \text{ MeV} = 727 \times 10^{-2} \text{ MeV}$$

58. An ac source is connected in given series LCR circuit. The rms potential difference across the capacitor of $20 \mu\text{F}$ is V.

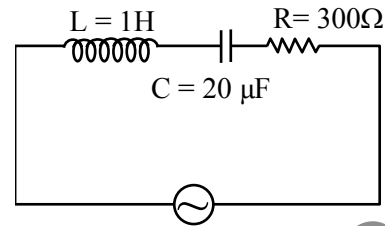

$$V = 50\sqrt{2} \sin 100t \text{ volt}$$

Ans. (50)

Sol. $X_L = \omega L = 100 \times 1 = 100 \Omega$

$$X_C = \frac{1}{\omega C} = \frac{1}{100 \times 20 \times 10^{-6}} = 500 \Omega$$

$$Z = \sqrt{(X_L - X_C)^2 + R^2}$$

$$\sqrt{(100 - 500)^2 + 300^2}$$

$$Z = 500 \Omega$$

$$i_{\text{rms}} = \frac{V_{\text{rms}}}{Z} = \frac{50}{500} = 0.1 \text{ A}$$

rms voltage across capacitor

$$V_{\text{rms}} = X_C i_{\text{rms}}$$

$$= 500 \times 0.1 = 50 \text{ V}$$

59. In the experiment to determine the galvanometer resistance by half-deflection method, the plot of $\frac{1}{\theta}$ vs the resistance (R) of the resistance box is shown in the figure. The figure of merit of the galvanometer is $\times 10^{-1}$ A/division. [The source has emf 2V]

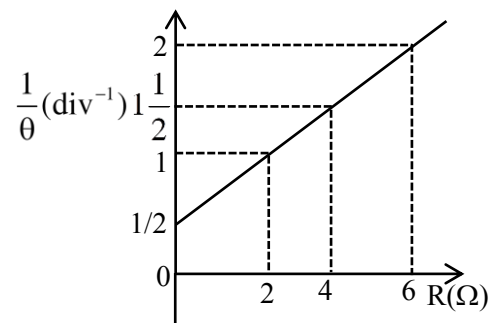

Ans. (5)

Sol. $i = K\theta$

$$\frac{2}{G+R} = K\theta$$

$$\Rightarrow \frac{1}{\theta} = \frac{(G+R)K}{2} = R\left(\frac{K}{2}\right) + \frac{KG}{2}$$

$$\text{Slope} = \frac{K}{2} = \frac{1}{4} \Rightarrow K = 0.5 = 5 \times 10^{-1} \text{ A}$$

60. Three capacitors of capacitances $25 \mu\text{F}$, $30 \mu\text{F}$ and $45 \mu\text{F}$ are connected in parallel to a supply of 100 V . Energy stored in the above combination is E . When these capacitors are connected in series to the same supply, the stored energy is $\frac{9}{x} E$. The value of x is

Ans. (86)

Sol. In parallel combination : Potential difference is same across all

$$\text{Energy} = \frac{1}{2}(C_1 + C_2 + C_3)V^2$$

$$= \frac{1}{2}(25 + 30 + 45) \times (100)^2 \times 10^{-6} = 0.5 = E$$

In series combination: Charge is same on all.

$$\frac{1}{C_{\text{equ}}} = \frac{1}{C_1} + \frac{1}{C_2} + \frac{1}{C_3} = \frac{1}{25} + \frac{1}{30} + \frac{1}{45}$$

$$\frac{1}{C_{\text{equ}}} = \frac{(18+15+10)}{450} = \frac{43}{450} \Rightarrow C_{\text{equ}} = \frac{450}{43}$$

$$\text{Energy} = \frac{Q^2}{2C_1} + \frac{Q^2}{2C_2} + \frac{Q^2}{2C_3}$$

$$= \frac{Q^2}{2} \left[\frac{1}{C_1} + \frac{1}{C_2} + \frac{1}{C_3} \right]$$

$$\frac{(V \times C_{\text{equ}})^2}{2} \times \frac{1}{C_{\text{equ}}} = \frac{V^2 C_{\text{equ}}}{2}$$

$$\frac{(100)^2}{2} \times \frac{450}{43} \times 10^{-6}$$

$$\Rightarrow \frac{4.5}{86} = \frac{9}{x} E = \frac{9}{x} \times 0.5 \Rightarrow x = 86$$

CHEMISTRY

SECTION-A

61. The **incorrect** postulates of the Dalton's atomic theory are :

- (A) Atoms of different elements differ in mass.
- (B) Matter consists of divisible atoms.
- (C) Compounds are formed when atoms of different element combine in a fixed ratio.
- (D) All the atoms of given element have different properties including mass.
- (E) Chemical reactions involve reorganisation of atoms.

Choose the **correct** answer from the options given below :

- (1) (B), (D), (E) only
- (2) (A), (B), (D) only
- (3) (C), (D), (E) only
- (4) (B), (D) only

Ans. (4)

Sol. B, D

62. The following reaction occurs in the Blast furnace where iron ore is reduced to iron metal

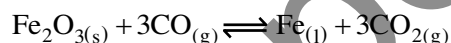

Using the Le-chatelier's principle, predict which one of the following will not disturb the equilibrium.

- (1) Addition of Fe_2O_3
- (2) Addition of CO_2
- (3) Removal of CO
- (4) Removal of CO_2

Ans. (1)

Sol. When solid added no effect on equilibrium.

TEST PAPER WITH SOLUTION

63. Identify compound (Z) in the following reaction sequence.

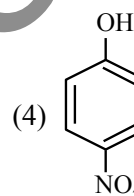
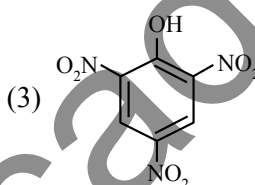
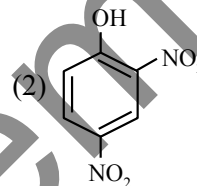
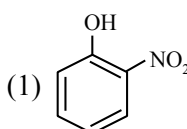
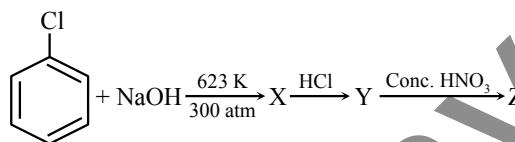

Ans. (3)

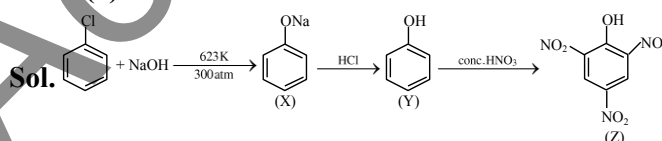

64. Given below are two statements : One is labelled as **Assertion (A)** and the other is labelled as **Reason (R)**

Assertion (A): Enthalpy of neutralisation of strong monobasic acid with strong monoacidic base is always -57 kJ mol^{-1}

Reason (R): Enthalpy of neutralisation is the amount of heat liberated when one mole of H^+ ions furnished by acid combine with one mole of OH^- ions furnished by base to form one mole of water.

In the light of the above statements, choose the **correct** answer from the options given below.

- (1) (A) is true but (R) is false
- (2) Both (A) and (R) are true and (R) is the correct explanation of (A)
- (3) (A) is false but (R) is true
- (4) Both (A) and (R) are true but (R) is **not** the correct explanation of (A)

Ans. (2)

Sol. Enthalpy of neutralization of SA & SB is always -57 kJ / mol because strong monoacid gives one mole of H^+ and strong mono base gives one mole of OH^- which form one mole of water.

65. The statement(s) that are **correct** about the species O^{2-} , F^- , Na^+ and Mg^{2+} .

- (A) All are isoelectronic
 (B) All have the same nuclear charge
 (C) O^{2-} has the largest ionic radii
 (D) Mg^{2+} has the smallest ionic radii

Choose the **most appropriate** answer from the options given below :

- (1) (B), (C) and (D) only
 (2) (A), (B), (C) and (D)
 (3) (C) and (D) only
 (4) (A), (C) and (D) only

Ans. (4)

Sol.	O^{2-}	F^-	Na^+	Mg^{+2}
(No. of e^-)	10	10	10	10
(Ionic radius)	$\text{O}^{2-} > \text{F}^- > \text{Na}^+ > \text{Mg}^{+2}$			
Z_{eff}	$\text{O}^{2-} < \text{F}^- < \text{Na}^+ < \text{Mg}^{+2}$			

66. For the compounds:

- (A) $\text{H}_3\text{C}-\text{CH}_2-\text{O}-\text{CH}_2-\text{CH}_2-\text{CH}_3$
 (B) $\text{H}_3\text{C}-\text{CH}_2-\text{CH}_2-\text{CH}_2-\text{CH}_3$
 (C) $\text{CH}_3-\text{CH}_2-\overset{\text{O}}{\parallel}{\text{C}}-\text{CH}_2-\text{CH}_3$

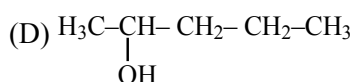

The increasing order of boiling point is :

Choose the **correct** answer from the options given below :

- (1) (A) < (B) < (C) < (D)
 (2) (B) < (A) < (C) < (D)
 (3) (D) < (C) < (A) < (B)
 (4) (B) < (A) < (D) < (C)

Ans. (2)

Sol. Compounds having same number of carbon atoms follow the boiling point order as:

(Boiling point)_{Hydrogen bonding} > (Boiling point)_{high polarity} > (Boiling point)_{low polarity} > (Boiling point)_{non polar}

67. Given below are two statements :

Statement I: In group 13, the stability of +1 oxidation state increases down the group.

Statement II: The atomic size of gallium is greater than that of aluminium.

In the light of the above statements, choose the **most appropriate** answer from the options given below:

- (1) **Statement I** is incorrect but **Statement II** is correct
 (2) Both **Statement I** and **Statement II** are correct
 (3) Both **Statement I** and **Statement II** are incorrect
 (4) **Statement I** is correct but **Statement II** is incorrect

Ans. (4)

Sol. Statement I: Number of d & f electrons, increases down the group and due to poor shielding of d & f e^- , stability of lower oxidation states increases down the group

Statement II: The atomic size of aluminium is greater than that of gallium.

68. Number of σ and π bonds present in ethylene molecule is respectively :

- (1) 3 and 1
 (2) 5 and 2
 (3) 4 and 1
 (4) 5 and 1

Ans. (4)

Sol. ethylene is $\text{H}_2\text{C}=\text{CH}_2$, it has 5 σ bonds and

1 π bond.

69. Identify 'A' in the following reaction :

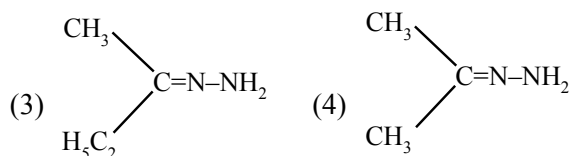
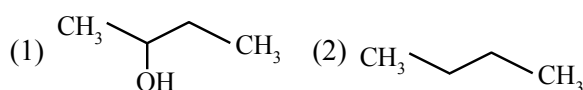
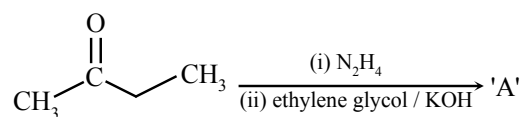

Ans. (2)

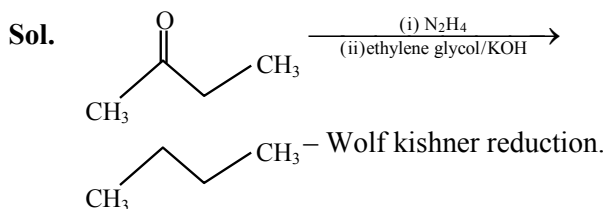

70. The reaction at cathode in the cells commonly used in clocks involves.

- (1) reduction of Mn from +4 to +3
- (2) oxidation of Mn from +3 to +4
- (3) reduction of Mn from +7 to +2
- (4) oxidation of Mn from +2 to +7

Ans. (1)

Sol. In the cathode reaction manganese (Mn) is reduced from the +4 oxidation state to the +3 state.

71. Which one of the following complexes will exhibit the least paramagnetic behaviour ?

[Atomic number, Cr = 24, Mn = 25, Fe = 26, Co = 27]

- (1) $[\text{Co}(\text{H}_2\text{O})_6]^{2+}$
- (2) $[\text{Fe}(\text{H}_2\text{O})_6]^{2+}$
- (3) $[\text{Mn}(\text{H}_2\text{O})_6]^{2+}$
- (4) $[\text{Cr}(\text{H}_2\text{O})_6]^{2+}$

Ans. (1)

Sol.

	Number of unpaired e^-	$\mu = \sqrt{n(n+2)}$ B.M.
$[\text{Co}(\text{H}_2\text{O})_6]^{2+}$	3	3.87
$[\text{Fe}(\text{H}_2\text{O})_6]^{2+}$	4	4.89
$[\text{Mn}(\text{H}_2\text{O})_6]^{2+}$	5	5.92
$[\text{Cr}(\text{H}_2\text{O})_6]^{2+}$	4	4.89

Least paramagnetic behaviour = $[\text{Co}(\text{H}_2\text{O})_6]^{2+}$

72. Given below are two statements : one is labelled as **Assertion (A)** and the other is labelled as **Reason (R)**.

Assertion (A): Cis form of alkene is found to be more polar than the trans form

Reason (R): Dipole moment of trans isomer of 2-butene is zero.

In the light of the above statements, choose the **correct** answer from the options given below :

- (1) Both **(A)** and **(R)** are true but **(R)** is **NOT** the correct explanation of **(A)**
- (2) **(A)** is true but **(R)** is false
- (3) Both **(A)** and **(R)** are true and **(R)** is the correct explanation of **(A)**
- (4) **(A)** is false but **(R)** is true

Ans. (3)

Sol. Dipole moment is a vector quantity and for compound net dipole moment is the vector sum of all dipoles hence dipole moment of cis form is greater than trans form.

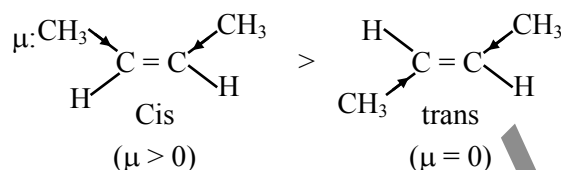

73. Given below are two statements :

Statement I: Nitration of benzene involves the following step –

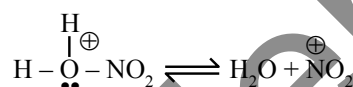

Statement II: Use of Lewis base promotes the electrophilic substitution of benzene.

In the light of the above statements, choose the **most appropriate** answer from the options given below :

- (1) Both **Statement I** and **Statement II** are incorrect
- (2) **Statement I** is correct but **Statement II** is incorrect
- (3) Both **Statement I** and **Statement II** are correct
- (4) **Statement I** is incorrect but **Statement II** is correct

Ans. (2)

Sol. In nitration of benzene concentrated H_2SO_4 and HNO_3 is used as reagent which generates electrophile $\overset{\oplus}{\text{NO}_2}$ in following steps:

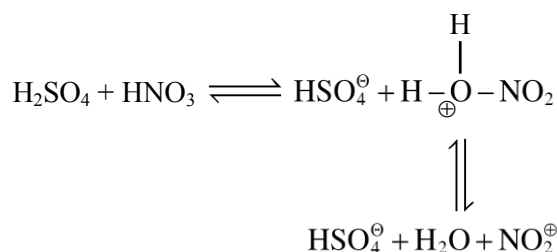

Lewis acids can promote the formation of electrophiles not Lewis base

74. The correct order of ligands arranged in increasing field strength.

- (1) $\text{Cl}^- < \text{OH}^- < \text{Br}^- < \text{CN}^-$
(2) $\text{F}^- < \text{Br}^- < \text{I}^- < \text{NH}_3$
(3) $\text{Br}^- < \text{F}^- < \text{H}_2\text{O} < \text{NH}_3$
(4) $\text{H}_2\text{O} < \text{OH}^- < \text{CN}^- < \text{NH}_3$

Ans. (3)

Sol. Experimental order $\text{Br}^- < \text{F}^- < \text{H}_2\text{O} < \text{NH}_3$

75. Which of the following gives a positive test with ninhydrin ?

- (1) Cellulose (2) Starch
(3) Polyvinyl chloride (4) Egg albumin

Ans. (4)

Sol. Ninhydrin test is a test of amino acids. Egg albumin contains protein which is a natural polymer of amino acids which will show positive ninhydrin test

76. The metal that shows highest and maximum number of oxidation state is:

- (1) Fe (2) Mn
(3) Ti (4) Co

Ans. (2)

Sol. Mn shows highest oxidation state (Mn^{+7}) in 3d series metals.

77. Ail organic compound has 42.1% carbon, 6.4% hydrogen and remainder is oxygen. If its molecular weight is 342, then its molecular formula is :

- (1) $\text{C}_{11}\text{H}_{18}\text{O}_{12}$ (2) $\text{C}_{12}\text{H}_{20}\text{O}_{12}$
(3) $\text{C}_{14}\text{H}_{20}\text{O}_{10}$ (4) $\text{C}_{12}\text{H}_{22}\text{O}_{11}$

Ans. (4)

Sol. only $\text{C}_{12}\text{H}_{22}\text{O}_{11}$ has 42.1% carbon, 6.4% hydrogen & 51.5 percent oxygen.

78. Given below are two statement :

Statement I : Bromination of phenol in solvent with low polarity such as CHCl_3 or CS_2 requires Lewis acid catalyst.

Statement II : The lewis acid catalyst polarises the bromine to generate Br^+ .

In the light of the above statements, choose the correct answer from the options given below :

- (1) Statement I is true but Statement II is false.
(2) Both Statement I and Statement II are true
(3) Both Statement I and Statement II are false.
(4) Statement I is false but Statement II is true.

Ans. (4)

Sol. Phenol is a highly activated compound which can undergo bromination directly with Bromine without any lewis acid.

79. Molar ionic conductivities of divalent cation and anion are $57 \text{ S cm}^2 \text{ mol}^{-1}$ and $73 \text{ S cm}^2 \text{ mol}^{-1}$ respectively. The molar conductivity of solution of an electrolyte with the above cation and anion will be :

- (1) $65 \text{ S cm}^2 \text{ mol}^{-1}$ (2) $130 \text{ S cm}^2 \text{ mol}^{-1}$
(3) $187 \text{ S cm}^2 \text{ mol}^{-1}$ (4) $260 \text{ S cm}^2 \text{ mol}^{-1}$

Ans. (2)

Sol. $\Lambda_{\text{C}}^{+2} = 57 \text{ S cm}^2 \text{ mol}^{-1}$

$$\Lambda_{\text{A}}^{+2} = 73 \text{ S cm}^2 \text{ mol}^{-1}$$

$$\Lambda_{\text{Solution}} = \lambda_{\text{C}}^{+2} + \Lambda_{\text{A}}^{-2}$$
$$= 57 + 73 = 130$$

80. The number of neutrons present in the more abundant isotope of boron is 'x'. Amorphous boron upon heating with air forms a product, in which the oxidation state of boron is 'y'. The value of x + y is ...

- (1) 4 (2) 6
(3) 3 (4) 9

Ans. (4)

Sol. More abundant isotope = B^{11}

[Number of neutrons = 6]

$$x = 6$$

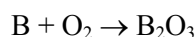

Oxidation state of B in $\text{B}_2\text{O}_3 = +3$

$$\text{So, } y = 3$$

$$\text{Hence } x + y = 9$$

SECTION-B

81. The value of Rydberg constant (R_{H}) is $2.18 \times 10^{-18} \text{ J}$. The velocity of electron having mass $9.1 \times 10^{-31} \text{ kg}$ in Bohr's first orbit of hydrogen atom = $\times 10^5 \text{ ms}^{-1}$ (nearest integer)

Ans. (22)

Sol. $V = 2.18 \times 10^6 \times \frac{Z}{n}$

$$= 21.8 \times 10^5 \times \frac{1}{1} \approx 22 \times 10^5 \text{ (nearest)}$$

82.

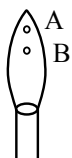

In a borax bead test under hot condition, a metal salt (one from the given) is heated at point B of the flame, resulted in green colour salt bead. The spin-only magnetic moment value of the salt is BM (Nearest integer)

[Given atomic number of Cu = 29, Ni = 28, Mn = 25, Fe = 26]

Ans. (6)

Sol. Fe^{+3} will give green coloured bead when heated at point B.

Number of unpaired e^- in $\text{Fe}^{+3} = 5$

$$\mu = 5.92$$

Nearest integer = 6

83. The heat of combustion of solid benzoic acid at constant volume is -321.30 kJ at 27°C . The heat of combustion at constant pressure is $(-321.30 - xR)$ kJ, the value of x is

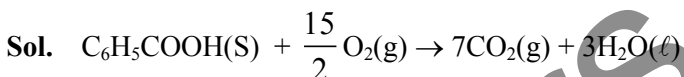
Ans. (150)

$$\Delta H = \Delta U + \Delta n_g RT$$

$$= -321.30 - \frac{1}{2} \frac{R}{100} \times 300$$

$$= (-321.30 - 150R) \text{ kJ}$$

84. Consider the given chemical reaction sequence :



Total sum of oxygen atoms in Product A and Product B are

Ans. (14)

Sol. Picric acid is prepared by treating phenol first with concentrated sulphuric acid which converts it to phenol-2,4-disulphonic acid and then with concentrated nitric acid to get 2, 4, 6 trinitrophenol.

85. The spin only magnetic moment value of the ion among Ti^{2+} , V^{2+} , Co^{3+} and Cr^{2+} , that acts as strong oxidising agent in aqueous solution is BM (Near integer).

(Given atomic numbers : Ti : 22, V : 23, Cr : 24, Co : 27)

Ans. (5)

Sol. Strong oxidising agent = Co^{+3}

No. of unpaired e^- in $\text{Co}^{+3}[\text{3d}^6] = 4$

$$\text{Hence } \mu = \sqrt{n(n+2)} = \sqrt{24} \text{ BM}$$

Nearest integer = 5

86. During Kinetic study of reaction $2\text{A} + \text{B} \rightarrow \text{C} + \text{D}$, the following results were obtained :

	A[M]	B[M]	initial rate of formation of D
I	0.1	0.1	6.0×10^{-3}
II	0.3	0.2	7.2×10^{-2}
III	0.3	0.4	2.88×10^{-1}
IV	0.4	0.1	2.40×10^{-2}

Based on above data, overall order of the reaction is

Ans. (3)

Sol. $r = K[\text{A}]^x[\text{B}]^y$

$$\text{(I)} \quad 6 \times 10^{-3} = K[0.1]^x[0.1]^y$$

$$\text{(IV)} \quad 2.4 \times 10^{-2} = K[0.4]^x[0.1]^y$$

$$\text{(IV)/(I)}$$

$$4 = (4)^x$$

$$x = 1$$

$$r = K[\text{A}]^x[\text{B}]^y$$

$$\text{(III)} \quad 2.88 \times 10^{-1} = K[0.3]^x[0.4]^y$$

$$\text{(II)} \quad 7.2 \times 10^{-2} = K[0.3]^x[0.2]^y$$

$$\text{(III)/(II)}$$

$$4 = 2^y$$

$$y = 2$$

$$\text{Overall order} = x + y = 1 + 2 = 3$$

87. An artificial cell is made by encapsulating 0.2 M glucose solution within a semipermeable membrane. The osmotic pressure developed when the artificial cell is placed within a 0.05 M solution of NaCl at 300 K is _____ $\times 10^{-1}$ bar. (Nearest Integer)

[Given : $R = 0.083 \text{ L bar mol}^{-1} \text{ K}^{-1}$]

Assume complete dissociation of NaCl

Ans. (25)

Sol.

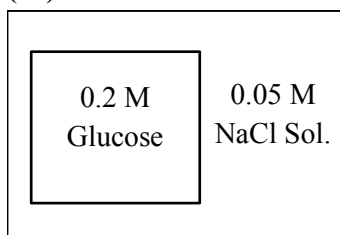

0.05M 0.05M 0.05M

Total $C_1 = 0.05 + 0.05 = 0.1 \text{ M (NaCl)}$

$C_2 = 0.2 \text{ M (glucose)}$

$$\pi = (C_2 - C_1) RT$$

$$= (0.2 - 0.1) \times 0.083 \times 300$$

$$= 2.49 \text{ bar}$$

$$= 24.9 \times 10^{-1} \text{ bar}$$

88. The number of halobenzenes from the following that can be prepared by Sandmeyer's reaction is

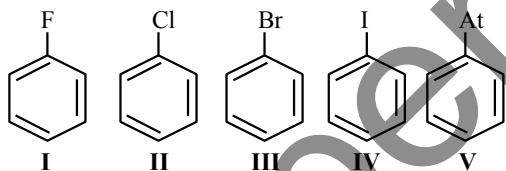

Ans. (2)

Sol. In Sandmeyer reaction only bromobenzene & chlorobenzene are prepared

89. In the lewis dot structure for NO_2^- , total number of valence electrons around nitrogen is

Ans. (8)

Sol.

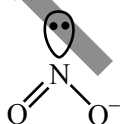

Number of valence e^- around N-atom = 8

90. 9.3 g of pure aniline is treated with bromine water at room temperature to give a white precipitate of the product 'P'. The mass of product 'P' obtained is 26.4 g. The percentage yield is

Ans. (80)

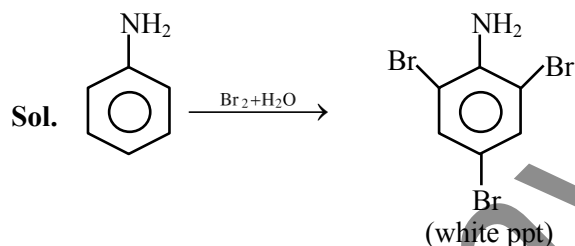

93 g of aniline produces 330 g of 2, 4, 6-tribromoaniline. Hence 9.3 g of aniline should produce 33g of 2, 4, 6-tribromoaniline. Hence

$$\text{percentage yield} = \frac{26.4 \times 100}{33} = 80\%$$

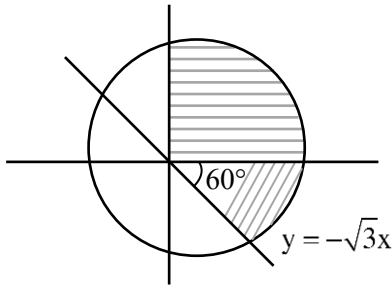

4. The area enclosed between the curves $y = x|x|$ and $y = x - |x|$ is :

- (1) $\frac{8}{3}$ (2) $\frac{2}{3}$
 (3) 1 (4) $\frac{4}{3}$

Ans. (4)

Sol.

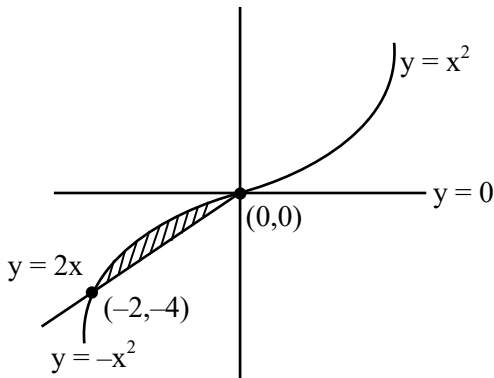

$$A = \int_{-2}^0 -x^2 - 2x = \frac{4}{3}$$

5. 60 words can be made using all the letters of the word BHBJO, with or without meaning. If these words are written as in a dictionary, then the 50th word is :

- (1) OBBHJ (2) HBBJO
 (3) OBBJH (4) JBBOH

Ans. (3)

Sol. B B H J O

\boxed{B} $\frac{4!}{1!} = 24$

\boxed{H} $\frac{4!}{2!} = 12$

\boxed{J} $\frac{4!}{2!} = 12$

O B B H J

O B B J H \rightarrow 50th rank

6. Let $\vec{a} = 2\hat{i} + 5\hat{j} - \hat{k}$, $\vec{b} = 2\hat{i} - 2\hat{j} + 2\hat{k}$ and \vec{c} be three vectors such that $(\vec{c} + \hat{i}) \times (\vec{a} + \vec{b} + \hat{i}) = \vec{a} \times (\vec{c} + \hat{i})$. $\vec{a} \cdot \vec{c} = -29$,

then $\vec{c} \cdot (-2\hat{i} + \hat{j} + \hat{k})$ is equal to :

- (1) 10 (2) 5
 (3) 15 (4) 12

Ans. (2)

Sol. Let's assume $\vec{v} = \vec{a} + \vec{b} + \hat{i}$

$$= 5\hat{i} + 3\hat{j} + \hat{k}$$

and $\vec{c} + \hat{i} = \vec{p}$

So,

$$\vec{p} \times \vec{v} = \vec{a} \times \vec{p}$$

$$\vec{p} \times \vec{v} + \vec{p} \times \vec{a} = \vec{0}$$

$$\vec{p} \times (\vec{v} + \vec{a}) = \vec{0}$$

$$\Rightarrow \vec{p} = \lambda(\vec{v} + \vec{a})$$

$$\vec{c} + \hat{i} = \lambda(7\hat{i} + 8\hat{j})$$

$$\vec{a} \cdot \vec{c} + \vec{a} \cdot \hat{i} = \lambda \vec{a} \cdot (7\hat{i} + 8\hat{j})$$

$$-29 + 2 = \lambda(14 + 40)$$

$$\lambda = -\frac{1}{2}$$

$$\vec{c} \cdot (-2\hat{i} + \hat{j} + \hat{k}) + \hat{i} \cdot (-2\hat{i} + \hat{j} + \hat{k}) = \lambda(7\hat{i} + 8\hat{j}) \cdot (-2\hat{i} + \hat{j} + \hat{k})$$

$$= -\frac{1}{2}(-14 + 8) + 2 = 5$$

7. Consider three vectors $\vec{a}, \vec{b}, \vec{c}$. Let $|\vec{a}| = 2, |\vec{b}| = 3$

and $\vec{a} = \vec{b} \times \vec{c}$. If $\alpha \in \left[0, \frac{\pi}{3}\right]$ is the angle between

the vectors \vec{b} and \vec{c} , then the minimum value of

$27|\vec{c} - \vec{a}|^2$ is equal to :

- (1) 110 (2) 105
 (3) 124 (4) 121

Ans. (3)

Sol. $|\vec{c} - \vec{a}| = |\vec{c}|^2 + |\vec{a}|^2 - 2\vec{a} \cdot \vec{c}$
 $= |\vec{c}|^2 + 4 - 0$

$\therefore \vec{a} = \vec{b} \times \vec{c}$

$|\vec{a}| = |\vec{b} \times \vec{c}|$

$2 = 3|\vec{c}|\sin\alpha$

$|\vec{c}| = \frac{2}{3} \operatorname{cosec}\alpha \quad \alpha \in \left[0, \frac{\pi}{3}\right]$

$|\vec{c}|_{\min} = \frac{2}{3} \times \frac{2}{\sqrt{3}} \quad \operatorname{cosec}\alpha \in \left[\frac{2}{\sqrt{3}}, \infty\right)$

$\Rightarrow 27|\vec{c} - \vec{a}|_{\min}^2 = 27\left(\frac{16}{27} + 4\right) = 124$

8. Let A(-1, 1) and B(2, 3) be two points and P be a variable point above the line AB such that the area of ΔPAB is 10. If the locus of P is $ax + by = 15$, then $5a + 2b$ is :

(1) $-\frac{12}{5}$ (2) $-\frac{6}{5}$

(3) 4 (4) 6

Ans. (1)

Sol.

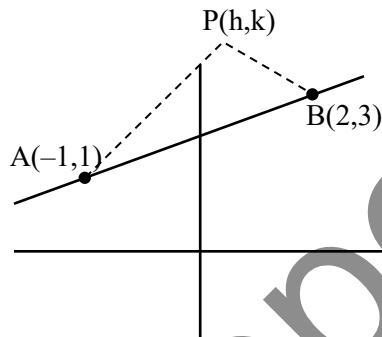

$\frac{1}{2} \begin{vmatrix} h & k & 1 \\ -1 & 1 & 1 \\ 2 & 3 & 1 \end{vmatrix} = 10$

$-2x + 3y = 25$

$-\frac{6}{5}x + \frac{9}{5}y = 15$

$a = -\frac{6}{5}, b = \frac{9}{5}$

$5a = -6, 2b = \frac{18}{5}$

9. Let (α, β, γ) be the point (8, 5, 7) in the line $\frac{x-1}{2} = \frac{y+1}{3} = \frac{z-2}{5}$. Then $\alpha + \beta + \gamma$ is equal to

(1) 16 (2) 18

(3) 14 (4) 20

Ans. (3)

Sol.

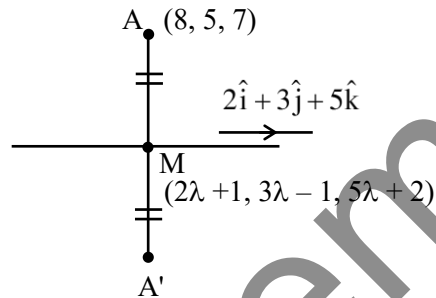

$\overline{AM} \cdot (2\hat{i} + 3\hat{j} + 5\hat{k}) = 0$

$(2\lambda - 7)(2) + (3\lambda - 6)(3) + (5\lambda - 5)(5) = 0$

$38\lambda = 57$

$\lambda = \frac{3}{2}$

$M\left(4, \frac{7}{2}, \frac{19}{2}\right)$

$A'(0, 2, 12)$

10. If the constant term in the expansion of

$\left(\frac{\sqrt[5]{3}}{x} + \frac{2x}{\sqrt[3]{5}}\right)^{12}$, $x \neq 0$, is $\alpha \times 2^8 \times \sqrt[5]{3}$, then 25α is

equal to :

(1) 639 (2) 724

(3) 693 (4) 742

Ans. (3)

Sol. $T_{r+1} = {}^{12}C_r \left(\frac{3^{1/5}}{x}\right)^{12-r} \left(\frac{2x}{5^{1/3}}\right)^r$

$T_{r+1} = \frac{{}^{12}C_r (3)^{\frac{12-r}{5}} (2)^r (x)^{2r-12}}{(5)^{r/3}}$

$r = 6$

$T_7 = \frac{{}^{12}C_6 (3)^{6/5} (2)^6}{5^2} = \left(\frac{9 \times 11 \times 7}{25}\right) 2^8 \cdot 3^{1/5}$

$25\alpha = 693$

11. Let $f, g : \mathbb{R} \rightarrow \mathbb{R}$ be defined as : $f(x) = |x - 1|$ and $g(x) = \begin{cases} e^x, & x \geq 0 \\ x+1, & x < 0 \end{cases}$. Then the function $f(g(x))$ is
- (1) neither one-one nor onto.
 (2) one-one but not onto.
 (3) both one-one and onto.
 (4) onto but not one-one.

Ans. (1)

Sol. $f(g(x)) = |g(x) - 1|$

$$f \circ g \begin{cases} |e^x - 1| & x \geq 0 \\ |x+1-1| & x < 0 \end{cases}$$

$$f \circ g \begin{cases} e^x - 1 & x \geq 0 \\ -x & x < 0 \end{cases}$$

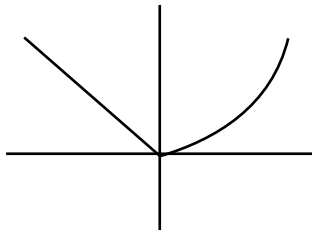

12. Let the circle $C_1 : x^2 + y^2 - 2(x + y) + 1 = 0$ and C_2 be a circle having centre at $(-1, 0)$ and radius 2. If the line of the common chord of C_1 and C_2 intersects the y-axis at the point P, then the square of the distance of P from the centre of C_1 is :

- (1) 2 (2) 1
 (3) 6 (4) 4

Ans. (1)

Sol. $S_1 : x^2 + y^2 - 2x - 2y + 1 = 0$

$S_2 : x^2 + y^2 + 2x - 3 = 0$

Common chord = $S_1 - S_2 = 0$

$-4x - 2y + 4 = 0$

$2x + y = 2 \Rightarrow P(0, 2)$

$d_{(c,p)}^2 = (1 - 0)^2 + (2 - 1)^2 = 2$

13. Let the set $S = \{2, 4, 8, 16, \dots, 512\}$ be partitioned into 3 sets A, B, C with equal number of elements such that $A \cup B \cup C = S$ and $A \cap B = B \cap C = A \cap C = \phi$. The maximum number of such possible partitions of S is equal to :

- (1) 1680 (2) 1520
 (3) 1710 (4) 1640

Ans. (1)

Sol.

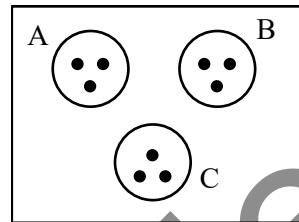

$$\frac{9!}{(3!3!3!)3!} \times 3!$$

14. The values of m, n, for which the system of equations

$$\begin{aligned} x + y + z &= 4, \\ 2x + 5y + 5z &= 17, \\ x + 2y + mz &= n \end{aligned}$$

has infinitely many solutions, satisfy the equation :

- (1) $m^2 + n^2 - m - n = 46$
 (2) $m^2 + n^2 + m + n = 64$
 (3) $m^2 + n^2 + mn = 68$
 (4) $m^2 + n^2 - mn = 39$

Ans. (4)

Sol. $D = \begin{vmatrix} 1 & 1 & 1 \\ 2 & 5 & 5 \\ 1 & 2 & m \end{vmatrix} = 0 \Rightarrow m = 2$

$$D_3 = \begin{vmatrix} 1 & 1 & 4 \\ 2 & 5 & 17 \\ 1 & 2 & n \end{vmatrix} = 0 \Rightarrow n = 7$$

15. The coefficients a, b, c in the quadratic equation $ax^2 + bx + c = 0$ are from the set $\{1, 2, 3, 4, 5, 6\}$. If the probability of this equation having one real root bigger than the other is p, then $216p$ equals :

- (1) 57 (2) 38
 (3) 19 (4) 76

Ans. (2)

19. If $y(\theta) = \frac{2\cos\theta + \cos 2\theta}{\cos 3\theta + 4\cos 2\theta + 5\cos\theta + 2}$,
then at $\theta = \frac{\pi}{2}$, $y'' + y' + y$ is equal to:

- (1) $\frac{3}{2}$ (2) 1
(3) $\frac{1}{2}$ (4) 2

Ans. (4)

Sol. $y = \frac{2\cos\theta + 2\cos^2\theta - 1}{4\cos^3\theta - 3\cos\theta + 8\cos^2\theta - 4 + 5\cos\theta + 2}$

$$y = \frac{(2\cos^2\theta + 2\cos\theta - 1)}{(2\cos^2\theta + 2\cos\theta - 1)(2\cos\theta + 2)}$$

$$y = \frac{1}{2} \left(\frac{1}{1 + \cos\theta} \right)$$

$$\Rightarrow \theta = \frac{\pi}{2} \quad y = \frac{1}{2}$$

$$y' = \frac{1}{2} \left(\frac{-1}{(1 + \cos\theta)^2} \times (-\sin\theta) \right)$$

$$\Rightarrow \theta = \frac{\pi}{2} \quad y = \frac{1}{2}$$

$$y'' = \frac{1}{2} \left[\frac{\cos\theta(1 + \cos\theta)^2 - \sin\theta(2)(1 + \cos\theta)(-\sin\theta)}{(1 + \cos\theta)^4} \right]$$

$$\Rightarrow \theta = \frac{\pi}{2} \quad y = 1$$

20. For $x \geq 0$, the least value of K, for which $4^{1+x} + 4^{1-x}$, $\frac{K}{2}$, $16^x + 16^{-x}$ are three consecutive terms of an A.P. is equal to:

- (1) 10 (2) 4
(3) 8 (4) 16

Ans. (1)

Sol. $k = 4 \left(4^x + \frac{1}{4^x} \right) + \left(4^{2x} + \frac{1}{4^{2x}} \right)$
 $\geq 2 \quad \geq 2$

$$k \geq 10$$

SECTION-B

21. Let the mean and the standard deviation of the probability distribution

X	α	1	0	-3
P(X)	$\frac{1}{3}$	K	$\frac{1}{6}$	$\frac{1}{4}$

be μ and σ , respectively. If $\sigma - \mu = 2$, then $\sigma + \mu$ is equal to _____.

Ans. (5)

Sol. $\frac{1}{3} + k + \frac{1}{6} + \frac{1}{4} = 1 \Rightarrow k = \frac{1}{4}$

$$\mu = \frac{\alpha}{3} + \frac{1}{4} - \frac{3}{4}$$

$$\mu = \frac{\alpha}{3} - \frac{1}{2}$$

$$\sigma = \sqrt{\left(\alpha^2 \frac{1}{3} + \frac{1}{4} + 9 \frac{1}{4} \right) - \left(\frac{\alpha}{3} - \frac{1}{2} \right)^2}$$

$$\sigma = \sqrt{\frac{2\alpha^2}{9} + \frac{\alpha}{3} + \frac{9}{4}}$$

$$\sigma = \mu + 2$$

$$\sigma^2 = (\mu + 2)^2 \Rightarrow \frac{2\alpha^2}{9} + \frac{\alpha}{3} + \frac{9}{4} = \frac{\alpha^2}{9} + \frac{9}{4} + \alpha$$

$$\frac{\alpha^2}{9} - \frac{2\alpha}{3} = 0$$

$$\alpha = 0, \text{ (reject) or } \alpha = 6$$

($\because x = 0$ is already given)

$$\Rightarrow \sigma + \mu = 2\mu + 2$$

$$= 5$$

22. Let $y = y(x)$ be the solution of the differential

equation $\frac{dy}{dx} + \frac{2x}{(1+x^2)^2} y = x e^{\frac{1}{(1+x^2)}}$; $y(0) = 0$.

Then the area enclosed by the curve

$f(x) = y(x) e^{-\frac{1}{(1+x^2)}}$ and the line $y - x = 4$ is _____.

Ans. (18)

Sol. $IF = e^{\int \frac{2x}{(1+x^2)^2} dx} = e^{\frac{-1}{1+x^2}}$
 $y \cdot e^{\frac{-1}{1+x^2}} = \int x \cdot e^{\frac{1}{1+x^2}} \cdot e^{\frac{-1}{1+x^2}} dx$
 $y \cdot e^{\frac{-1}{1+x^2}} = \frac{x^2}{2} + c$

$(0, 0) \Rightarrow \boxed{C=0}$

$y(x) = \frac{x^2}{2} e^{\frac{1}{1+x^2}}$

$f(x) = \frac{x^2}{2}$

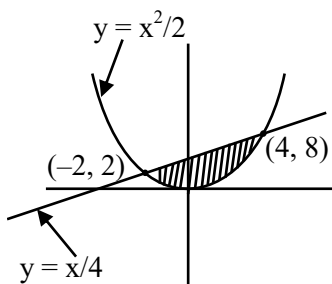

$A = \int_{-2}^4 (x+4) - \frac{x^2}{2} dx = 18$

23. The number of solutions of $\sin^2 x + (2 + 2x - x^2)\sin x - 3(x-1)^2 = 0$, where $-\pi \leq x \leq \pi$, is

Ans. (2)

Sol. $\sin^2 x - (x^2 - 2x - 2)\sin x - 3(x-1)^2 = 0$
 $\sin^2 x - (x-1)^2 \sin x - 3(x-1)^2 = 0$

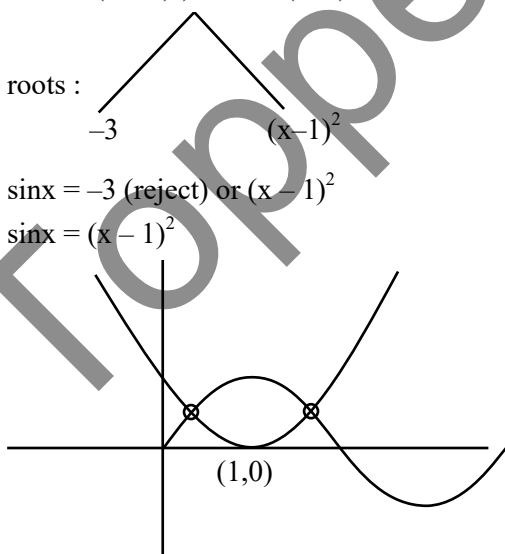

24. Let the point $(-1, \alpha, \beta)$ lie on the line of the shortest distance between the lines $\frac{x+2}{-3} = \frac{y-2}{4} = \frac{z-5}{2}$ and $\frac{x+2}{-1} = \frac{y+6}{2} = \frac{z-1}{0}$.

Then $(\alpha - \beta)^2$ is equal to _____.

Ans. (25)

Sol.

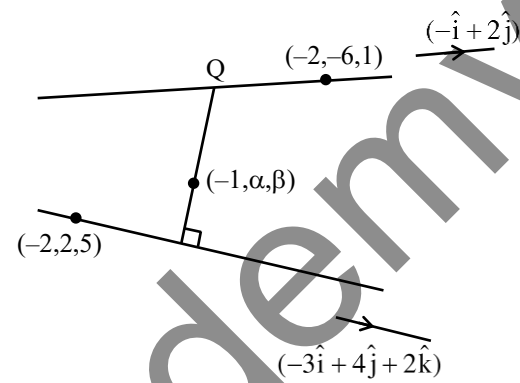

$P(-3\lambda - 2, 4\lambda + 2, 2\lambda + 5)$

$Q(-\mu - 2, 2\mu - 6, 1)$

DRS of PQ = $(3\lambda - \mu, 2\mu - 4\lambda - 8, -2\lambda - 4)$

DRS of PQ = $\begin{vmatrix} \hat{i} & \hat{j} & \hat{k} \\ -1 & 2 & 0 \\ -3 & 4 & 2 \end{vmatrix}$

$= (4\hat{i} + 2\hat{j} + 2\hat{k})$

OR

$(2, 1, 1)$

$\frac{3\lambda - \mu}{2} = \frac{2\mu - 4\lambda - 8}{1} = \frac{-2\lambda - 4}{1}$

$\Rightarrow \mu = \lambda + 2$ & $7\lambda = \mu - 8$

$\boxed{\lambda = -1}$ $\boxed{\mu = 1}$

$Q : (-3, -4, 1)$

$L_{PQ} = \frac{x+3}{2} = \frac{y+4}{1} = \frac{z-1}{1}$

$(-1, \alpha, \beta) \Rightarrow 1 = \frac{\alpha+4}{1} = \frac{\beta-1}{1}$

$\Rightarrow \alpha = -3, \beta = 2$

$(\alpha - \beta)^2 = 25$

25. If

$$1 + \frac{\sqrt{3}-\sqrt{2}}{2\sqrt{3}} + \frac{5-2\sqrt{6}}{18} + \frac{9\sqrt{3}-11\sqrt{2}}{36\sqrt{3}} + \frac{49-20\sqrt{6}}{180} + \dots$$

upto $\infty = 2\left(\sqrt{\frac{b}{a}} + 1\right) \log_e\left(\frac{a}{b}\right)$, where a and b are

integers with $\gcd(a, b) = 1$, then $11a + 18b$ is equal to _____.

Ans. (76)

Sol. $S = 1 + \frac{x}{2\sqrt{3}} + \frac{x^2}{18} + \frac{x^3}{36\sqrt{3}} + \frac{x^4}{180} + \dots \infty$

Put $\frac{x}{\sqrt{3}} = t$, where $x = \sqrt{3} - \sqrt{2}$

$$S = 1 + \frac{t}{2} + \frac{t^2}{6} + \frac{t^3}{12} + \frac{t^4}{20} + \dots$$

$$S = 1 + t\left(1 - \frac{1}{2}\right) + t^2\left(\frac{1}{2} - \frac{1}{3}\right) + t^3\left(\frac{1}{3} - \frac{1}{4}\right) + t^4\left(\frac{1}{4} - \frac{1}{5}\right) + \dots$$

$$S = \left(1 + t + \frac{t^2}{2} + \frac{t^3}{3} + \frac{t^4}{4} + \dots\right) - \left(\frac{t}{2} + \frac{t^2}{3} + \frac{t^3}{4} + \frac{t^4}{5} + \dots\right)$$

$$S = \left(t + \frac{t^2}{2} + \dots\right) - \frac{1}{t} \left(t + \frac{t^2}{2} + \frac{t^3}{3} + \dots\right) + 2$$

$$S = 2 + \left(1 - \frac{1}{t}\right) (-\log(1-t)) = \left(\frac{1}{t} - 1\right) \log(1-t) + 2$$

$$S = 2 + \left(\frac{\sqrt{3}}{\sqrt{3}-\sqrt{2}} - 1\right) \log\left(1 - \frac{\sqrt{3}-\sqrt{2}}{\sqrt{3}}\right)$$

$$S = 2 + \left(\frac{\sqrt{2}}{\sqrt{3}-\sqrt{2}}\right) \log_e \frac{\sqrt{2}}{\sqrt{3}}$$

$$S = 2 + \frac{(\sqrt{6}+2)}{2} \log_e \frac{2}{3} = 2 + \left(\sqrt{\frac{3}{2}} + 1\right) \log_e \frac{2}{3}$$

$$a = 2, b = 3$$

$$11a + 18b = 11 \times 2 + 18 \times 3 = 76$$

26. Let $a > 0$ be a root of the equation $2x^2 + x - 2 = 0$.

If $\lim_{x \rightarrow \frac{1}{a}} \frac{16(1 - \cos(2 + x - 2x^2))}{(1 - ax^2)} = \alpha + \beta\sqrt{17}$, where

$\alpha, \beta \in \mathbb{Z}$ then $\alpha + \beta$ is equal to _____.

Ans. (170)

Sol. $2x^2 + x - 2 = 0$ $\begin{cases} \rightarrow a \\ \rightarrow b \end{cases}$

$2x^2 - x - 2 = 0$ $\begin{cases} \rightarrow \frac{1}{a} \\ \rightarrow \frac{1}{b} \end{cases}$

$$\lim_{x \rightarrow \frac{1}{a}} 16 \cdot \frac{\left(1 - \cos 2\left(x - \frac{1}{a}\right)\left(x - \frac{1}{b}\right)\right)}{4\left(x - \frac{1}{b}\right)^2} \times \frac{4\left(x - \frac{1}{b}\right)^2}{a^2\left(x - \frac{1}{a}\right)^2}$$

$$= 16 \times \frac{2\left(\frac{1}{a} - \frac{1}{b}\right)^2}{a^2\left(\frac{1}{a} - \frac{1}{b}\right)^2}$$

$$= \frac{32}{a^2} \left(\frac{17}{4}\right) = \frac{17.8}{a^2} = \frac{17 \times 8 \times 16}{(-1 + \sqrt{117})^2}$$

$$= \frac{136.16}{18.2\sqrt{7}} \times \frac{18 + 2\sqrt{7}}{18 + 2\sqrt{7}}$$

$$= \frac{136}{256} (18 + 2\sqrt{7}) \cdot 16$$

$$= 153 + 17\sqrt{17} = \alpha + \beta\sqrt{17}$$

$$\alpha + \beta = 153 + 17 = 170$$

27. If $f(t) = \int_0^{\pi} \frac{2x dx}{1 - \cos^2 t \sin^2 x}$, $0 < t < \pi$, then the value

of $\int_0^{\frac{\pi}{2}} \frac{\pi^2 dt}{f(t)}$ equals _____.

Ans. (1)

Sol. $f(t) = \int_0^{\pi} \frac{2x}{1 - \cos^2 t \sin^2 x} dx$ (1)

$$= 2 \int_0^{\pi} \frac{(\pi - x) dx}{1 - \cos^2 t \sin^2 x} \quad \dots(2)$$

$$2f(t) = 2 \int_0^{\pi} \frac{\pi}{1 - \cos^2 t \sin^2 x} dx$$

$$f(t) = \int_0^{\pi} \frac{\pi}{1 - \cos^2 t \sin^2 x} dx$$

divide & by $\cos^2 x$

$$f(t) = \pi \int_0^{\pi} \frac{\sec^2 x dx}{\sec^2 x - \cos^2 t \tan^2 x}$$

$$f(t) = 2\pi \int_0^{\pi/2} \frac{\sec^2 x dx}{\sec^2 x - \cos^2 t \tan^2 x}$$

$$\tan x = z$$

$$\sec^2 x dx = dz$$

$$f(t) = 2\pi \int_0^{\infty} \frac{dz}{1 + \sin^2 t \cdot z^2}$$

$$= \frac{\pi^2}{\sin t}$$

$$\text{Then } \int_0^{\pi/2} \frac{\pi^2}{f(t)} dt$$

$$= \int_0^{\pi/2} \sin t dt$$

$$= 1$$

28. Let the maximum and minimum values of $(\sqrt{8x - x^2 - 12} - 4)^2 + (x - 7)^2$, $x \in \mathbb{R}$ be M and m respectively. Then $M^2 - m^2$ is equal to _____.

Ans. (1600)

Sol. $(x - 7)^2 + (y - 4)^2$

$$y = \sqrt{8x - x^2 - 12}$$

$$y^2 = -(x - 4)^2 + 16 - 12$$

$$(x - 4)^2 + y^2 = 4$$

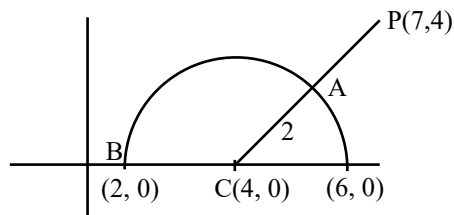

$$m = 9$$

$$M = 41$$

$$M^2 - m^2 = 41^2 - 9^2 = 1600$$

29. Let a line perpendicular to the line $2x - y = 10$ touch the parabola $y^2 = 4(x - 9)$ at the point P . The distance of the point P from the centre of the circle $x^2 + y^2 - 14x - 8y + 56 = 0$ is _____.

Ans. (10)

Sol. $y^2 = 4(x - 9)$

$$\text{slope of tangent} = \frac{-1}{2}$$

$$\text{Point of contact } P \left(9 + \frac{1}{\left(-\frac{1}{2}\right)^2}, \frac{2 \times 1}{2} \right)$$

$$P(13, -4)$$

$$\text{center of circle } C(7, 4)$$

$$\text{distance } CP = \sqrt{(13 - 7)^2 + (-4 - 4)^2} = 10$$

30. The number of real solutions of the equation $x|x + 5| + 2|x + 7| - 2 = 0$ is _____.

Ans. (3)

30. The number of real solutions of the equation $x|x + 5| + 2|x + 7| - 2 = 0$ is _____.

Allen Ans. (3)

Sol. Case I : $x \geq -5$

$$x^2 + 5x + 2x + 12 = 0$$

$$x^2 + 7x + 12 = 0$$

$$x = -3, -4$$

Case II : $-7 < x < -5$

$$-x^2 - 5x + 2x + 14 - 2 = 0$$

$$-x^2 - 3x + 12 = 0$$

$$x = \frac{-3 \pm \sqrt{9 + 48}}{2}$$

$$= \frac{-3 \pm \sqrt{57}}{2}$$

$$x = \frac{-3 - \sqrt{57}}{2}, \frac{-3 + \sqrt{57}}{2} \text{ (rejected)}$$

Case III : $x \leq -7$

$$-x^2 - 5x - 2x - 14 - 2 = 0$$

$$x^2 + 7x + 16 = 0$$

$$D = 49 - 64 < 0$$

No solutions

No. of solutions = 3

Toppers Academy

PHYSICS

TEST PAPER WITH SOLUTION

SECTION-A

31. Given below are two statements :

Statement I : When the white light passed through a prism, the red light bends lesser than yellow and violet.

Statement II : The refractive indices are different for different wavelengths in dispersive medium. In the light of the above statements, choose the correct answer from the options given below :

- (1) Both Statement I and Statement II are true.
- (2) Statement I is true but Statement II is false.
- (3) Both Statement I and Statement II are false.
- (4) Statement I is false but Statement II is true.

Ans. (1)

Sol. As $\lambda_{\text{red}} > \lambda_{\text{yellow}} > \lambda_{\text{violet}}$

Light ray with longer wavelength bends less.

32. Which of the following statement is not true about stopping potential (V_0)?

- (1) It depends on the nature of emitter material.
- (2) It depends upon frequency of the incident light.
- (3) It increases with increase in intensity of the incident light.
- (4) It is $1/e$ times the maximum kinetic energy of electrons emitted.

Ans. (3)

Sol. $KE_{\text{max}} = h\nu - \phi_0 = eV$

33. The angular momentum of an electron in a hydrogen atom is proportional to : (Where r is the radius of orbit of electron)

- (1) \sqrt{r}
- (2) $\frac{1}{r}$
- (3) r
- (4) $\frac{1}{\sqrt{r}}$

Ans. (1)

Sol. $F_C = \frac{mv^2}{r}$

$$\frac{Kq_1q_2}{r^2} = \frac{mv^2}{r}$$

$$mv^2r^2 = Kq_1q_2r$$

$$\frac{L^2}{m} = Kq_1q_2r$$

$$L \propto \sqrt{r}$$

34. A galvanometer of resistance 100Ω when connected in series with 400Ω measures a voltage of upto 10 V . The value of resistance required to convert the galvanometer into ammeter to read upto 10 A is $x \times 10^{-2} \Omega$. The value of x is :

- (1) 2
- (2) 800
- (3) 20
- (4) 200

Ans. (3)

Sol. $i_g = \frac{10}{400 + 100} = 20 \times 10^{-3} \text{ A}$

For ammeter

Let shunt resistance = S

$$i_g R = (i - i_g) S$$

$$20 \times 10^{-3} \times 100 = 10 S$$

$$S = 20 \times 10^{-2} \Omega$$

35. The vehicles carrying inflammable fluids usually have metallic chains touching the ground :

- (1) To conduct excess charge due to air friction to ground and prevent sparking.
- (2) To alert other vehicles.
- (3) To protect tyres from catching dirt from ground.
- (4) It is a custom.

Ans. (1)

Sol. Static charge is developed due to air friction. This can result in combustion. So, metallic chains is used to discharge excess charge.

36. If n is the number density and d is the diameter of the molecule, then the average distance covered by a molecule between two successive collisions (i.e. mean free path) is represented by :

- (1) $\frac{1}{\sqrt{2n\pi d^2}}$ (2) $\sqrt{2n\pi d^2}$
 (3) $\frac{1}{\sqrt{2n\pi d^2}}$ (4) $\frac{1}{\sqrt{2n^2\pi^2 d^2}}$

Ans. (3)

Sol. n = number of molecule per unit volume
 d = diameter of the molecule

$$\lambda = \frac{1}{\sqrt{2n\pi d^2}} \quad (\text{By Theory})$$

37. A particle moves in x-y plane under the influence of a force \vec{F} such that its linear momentum is $\vec{P}(t) = \hat{i} \cos(kt) - \hat{j} \sin(kt)$. If k is constant, the angle between \vec{F} and \vec{P} will be :

- (1) $\frac{\pi}{2}$ (2) $\frac{\pi}{6}$
 (3) $\frac{\pi}{4}$ (4) $\frac{\pi}{3}$

Ans. (1)

Sol. $\vec{P} = \cos(kt)\hat{i} - \sin(kt)\hat{j}$; $|\vec{P}| = 1$

$$\therefore \vec{P} = m\vec{v}$$

$$\therefore \hat{P} = \hat{v}$$

$$\Rightarrow \hat{v} = \cos(kt)\hat{i} - \sin(kt)\hat{j}$$

$$\hat{a} = \frac{-k \sin(kt)\hat{i} - k \cos(kt)\hat{j}}{k}$$

$$\Rightarrow \hat{a} = -\sin kt \hat{i} - \cos kt \hat{j}$$

$$\therefore \hat{F} = \hat{a} = -\sin kt \hat{i} - \cos kt \hat{j}$$

$$\cos \theta = \frac{\hat{F} \cdot \hat{P}}{|\hat{F}| |\hat{P}|} = -\frac{\sin kt \cos t + \sin kt \cos t}{1 \times 1} = 0$$

$$\Rightarrow \theta = \frac{\pi}{2}$$

38. The electrostatic force (\vec{F}_1) and magnetic force (\vec{F}_2) acting on a charge q moving with velocity v can be written :

- (1) $\vec{F}_1 = q\vec{V} \cdot \vec{E}$, $\vec{F}_2 = q(\vec{B} \cdot \vec{V})$
 (2) $\vec{F}_1 = q\vec{B}$, $\vec{F}_2 = q(\vec{B} \times \vec{V})$
 (3) $\vec{F}_1 = q\vec{E}$, $\vec{F}_2 = q(\vec{V} \times \vec{B})$
 (4) $\vec{F}_1 = q\vec{E}$, $\vec{F}_2 = q(\vec{B} \times \vec{V})$

Ans. (3)

Sol. $\vec{F}_1 = q\vec{E}$ (Theory)

$$\vec{F}_2 = q(\vec{V} \times \vec{B})$$

39. A man carrying a monkey on his shoulder does cycling smoothly on a circular track of radius 9m and completes 120 revolutions in 3 minutes. The magnitude of centripetal acceleration of monkey is (in m/s^2) :

- (1) zero (2) $16 \pi^2 ms^{-2}$
 (3) $4\pi^2 ms^{-2}$ (4) $57600 \pi^2 ms^{-2}$

Ans. (2)

Sol. Given : $R = 9m$,

120 revolution in 3 min

$$\omega = \frac{120 \text{ Rev.}}{3 \text{ min.}} = \frac{120 \times 2\pi \text{ rad}}{3 \times 60 \text{ sec}} = \frac{4\pi}{3} \text{ rad/s}$$

$$a_{\text{centripetal}} = \omega^2 R = \left(\frac{4\pi}{3}\right)^2 \times 9 = 16\pi^2 m/s^2$$

40. A series LCR circuit is subjected to an AC signal of 200 V, 50 Hz. If the voltage across the inductor ($L = 10 \text{ mH}$) is 31.4 V, then the current in this circuit is _____ :

- (1) 68 A (2) 63 A
 (3) 10 A (4) 10 mA

Ans. (3)

Sol. Voltage across inductor $V_L = IX_L$

$$31.4 = I[L\omega]$$

$$31.4 = I[L(2\pi f)]$$

$$31.4 = I[10 \times 10^{-3}(2 \times 3.14) \times 50]$$

$$\Rightarrow I = 10 \text{ A}$$

41. What is the dimensional formula of ab^{-1} in the equation $\left(P + \frac{a}{V^2}\right)(V - b) = RT$, where letters

have their usual meaning.

- (1) $[M^0L^3T^{-2}]$ (2) $[ML^2T^{-2}]$
 (3) $[M^{-1}L^5T^3]$ (4) $[M^6L^7T^4]$

Ans. (2)

Sol. $\therefore [V] = [b]$

\therefore Dimension of $b = [L^3]$

& $[P] = \left[\frac{a}{V^2}\right]$

$[a] = [PV^2] = [ML^{-1}T^{-2}][L^6]$

Dimension of $a = [ML^5T^{-2}]$

$\therefore ab^{-1} = \frac{[ML^5T^{-2}]}{[L^3]} = [ML^2T^{-2}]$

42. The output (Y) of logic circuit given below is 0 only when :

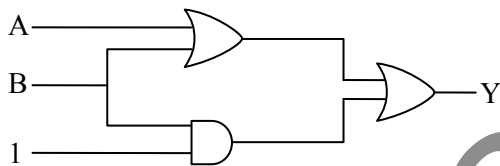

- (1) $A = 1, B = 0$ (2) $A = 0, B = 0$
 (3) $A = 1, B = 1$ (4) $A = 0, B = 1$

Ans. (2)

Sol.

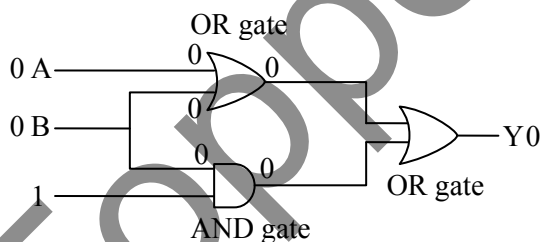

43. A body is moving unidirectionally under the influence of a constant power source. Its displacement in time t is proportional to :

- (1) t^2 (2) $t^{2/3}$
 (3) $t^{3/2}$ (4) t

Ans. (3)

Sol. $P = \text{constant} \Rightarrow FV = \text{constant}$

$\Rightarrow m \frac{dV}{dt} V = \text{constant}$

$\int_0^V V dV = (C) \int_0^t dt$

$\left(\frac{V^2}{2}\right) = Ct$

$V \propto t^{1/2}$

$\frac{ds}{dt} \propto t^{1/2}$

$\int_0^S ds = K \int_0^t t^{1/2} dt$

$S = K \times \frac{2}{3} t^{3/2}$

$S \propto t^{3/2}$

\therefore displacement is proportional to $(t)^{3/2}$

44. Match List-I with List-II :-

	List-I EM-Wave		List-II Wavelength Range
(A)	Infra-red	(I)	$< 10^{-3}$ nm
(B)	Ultraviolet	(II)	400 nm to 1 nm
(C)	X-rays	(III)	1 mm to 700 nm
(D)	Gamma rays	(IV)	1 nm to 10^{-3} nm

Choose the correct answer from the options given below :

- (1) (A)-(II), (B)-(I), (C)-(IV), (D)-(III)
 (2) (A)-(III), (B)-(II), (C)-(IV), (D)-(I)
 (3) (A)-(IV), (B)-(III), (C)-(II), (D)-(I)
 (4) (A)-(I), (B)-(III), (C)-(II), (D)-(IV)

Ans. (2)

Sol. Infrared is the least energetic thus having biggest wavelength (λ) & gamma rays are most energetic thus having smallest wavelength (λ).

48. A heavy box of mass 50 kg is moving on a horizontal surface. If coefficient of kinetic friction between the box and horizontal surface is 0.3 then force of kinetic friction is :

- (1) 14.7 N
 (2) 147 N
 (3) 1.47 N
 (4) 1470 N

Ans. (2)

Sol.

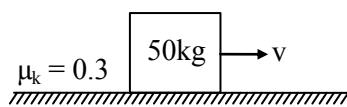

$$F_k = \mu_k N = 0.3 \times 50 \times 9.8 = 147 \text{ N}$$

49. A satellite revolving around a planet in stationary orbit has time period 6 hours. The mass of planet is one-fourth the mass of earth. The radius orbit of planet is : (Given = Radius of geo-stationary orbit for earth is $4.2 \times 10^4 \text{ km}$)

- (1) $1.4 \times 10^4 \text{ km}$
 (2) $8.4 \times 10^4 \text{ km}$
 (3) $1.68 \times 10^5 \text{ km}$
 (4) $1.05 \times 10^4 \text{ km}$

Ans. (4)

Sol. $T = \frac{2\pi r^{3/2}}{\sqrt{GM}}$

$$\frac{T_1}{T_2} = \left(\frac{r_1}{r_2}\right)^{3/2} \left(\frac{M_2}{M_1}\right)^{1/2}$$

$$\frac{6}{24} = \frac{(r_1)^{3/2}}{(4.2 \times 10^4)^{3/2}} \left(\frac{M}{M/4}\right)^{1/2}$$

$$r_1 = 1.05 \times 10^4 \text{ km}$$

50. The ratio of heat dissipated per second through the resistance 5Ω and 10Ω in the circuit given below is :

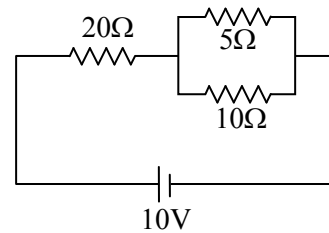

- (1) 1 : 2
 (2) 2 : 1
 (3) 4 : 1
 (4) 1 : 1

Ans. (2)

Sol.

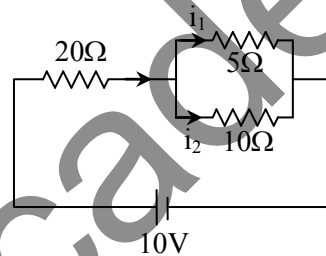

$$\frac{i_1}{i_2} = \frac{10}{5} = \frac{2}{1}$$

$$\frac{P_1}{P_2} = \frac{i_1^2 R_1}{i_2^2 R_2} = \left(\frac{2}{1}\right)^2 \times \frac{5}{10} = \frac{2}{1}$$

SECTION-B

51. A solenoid of length 0.5 m has a radius of 1 cm and is made up of 'm' number of turns. It carries a current of 5A. If the magnitude of the magnetic field inside the solenoid is $6.28 \times 10^{-3} \text{ T}$, then the value of m is :

Ans. (500)

Sol. $\mu_0 n i = B$ n = number of turns per unit length

$$\mu_0 \left(\frac{m}{\ell}\right) i = B$$

$$m = \frac{B \cdot \ell}{\mu_0 i} = \frac{6.28 \times 10^{-3} \times 0.5}{12.56 \times 10^{-7} \times 5}$$

$$m = 500$$

52. The shortest wavelength of the spectral lines in the Lyman series of hydrogen spectrum is 915 Å. The longest wavelength of spectral lines in the Balmer series will be _____ Å.

Ans. (6588)

Sol. Lyman Series

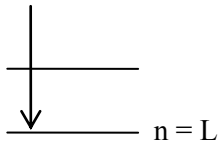

$$\text{Shortest, } \frac{hc}{\lambda} = -13.6 \left(\frac{1}{n_1^2} - \frac{1}{n_2^2} \right)$$

$$\lambda \downarrow E \uparrow ; \frac{hc}{\lambda_0} = -13.6(1)$$

Balmer Series :

$$\text{_____ } n = 3$$

$$\text{_____ } n = 2$$

$$\frac{hc}{\lambda_1} = -13.6 \left(\frac{1}{2^2} - \frac{1}{3^2} \right)$$

$$\frac{hc}{\lambda_1} = -13.6 \left(\frac{1}{4} - \frac{1}{9} \right)$$

$$\frac{hc}{\lambda_1} = -13.6 \times \left(\frac{5}{36} \right)$$

$$\Rightarrow \frac{-13.6\lambda_0}{\lambda_1} = -13.6 \times \frac{5}{36}$$

$$\lambda_1 = \frac{\lambda_0 \times 36}{5} = \frac{915 \times 36}{5} = 6588$$

53. In a single slit experiment, a parallel beam of green light of wavelength 550 nm passes through a slit of width 0.20 mm. The transmitted light is collected on a screen 100 cm away. The distance of first order minima from the central maximum will be $x \times 10^{-5}$ m. The value of x is :

Ans. (275)

Sol.

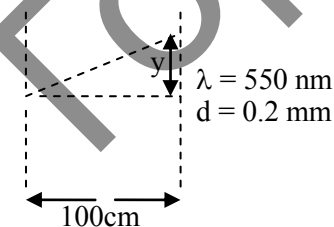

$$y = \frac{\lambda D}{d} = \frac{550 \times 10^{-9} \times 100 \times 10^{-2}}{0.2 \times 10^{-3}} = 275$$

54. A sonometer wire of resonating length 90 cm has a fundamental frequency of 400 Hz when kept under some tension. The resonating length of the wire with fundamental frequency of 600 Hz under same tension _____ cm.

Ans. (60)

Sol.

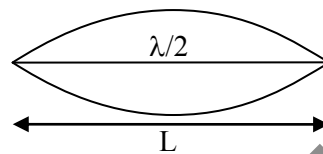

$$f_0 = 400 \text{ Hz}; v = \sqrt{\frac{T}{\mu}} = \text{constant}$$

$$\frac{\lambda}{2} = L; v = f_0 \lambda$$

$$\frac{v}{2f_0} = L \Rightarrow v = 2Lf_0$$

$$L' = \frac{v}{2f'} = \frac{2Lf_0}{2f'}$$

$$= \frac{Lf_0}{f'} = \frac{90 \times 400}{600} = 60$$

55. A hollow sphere is rolling on a plane surface about its axis of symmetry. The ratio of rotational kinetic energy to its total kinetic energy is $\frac{x}{5}$. The value of x is _____.

Ans. (2)

$$\text{Sol. } \frac{\frac{1}{2} I \omega^2}{\frac{1}{2} I \omega^2 + \frac{1}{2} m v^2} = \frac{\left(\frac{1}{2} \right) \left(\frac{2}{3} m R^2 \right) \omega^2}{\left(\frac{1}{2} \right) \left(\frac{2}{3} m R^2 \right) \omega^2 + \frac{1}{2} m (R \omega)^2}$$

$$= \frac{\frac{2}{3}}{\frac{2}{3} + 1} = \frac{2}{5}$$

$$x = 2$$

56. A hydraulic press containing water has two arms with diameters as mentioned in the figure. A force of 10 N is applied on the surface of water in the thinner arm. The force required to be applied on the surface of water in the thicker arm to maintain equilibrium of water is _____ N.

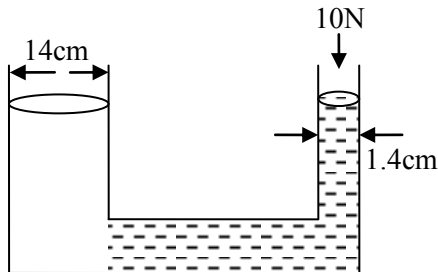

Ans. (1000 N)

Sol. $\frac{F_1}{A_1} = \frac{F_2}{A_2}$

$$\frac{F_1}{\pi(7)^2} = \frac{10}{\pi \times (0.7)^2}$$

$$F_1 = 1000 \text{ N}$$

57. The electric field at point p due to an electric dipole is E. The electric field at point R on

equatorial line will be $\frac{E}{x}$. The value of x :

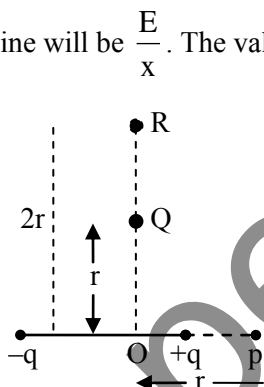

Ans. (16)

Sol. $E_p = \frac{2Kq}{r^3} = E$

$$E_R = \frac{Kq}{(2r)^3} = \frac{E}{16}$$

$$x = 16$$

58. The maximum height reached by a projectile is 64 m. If the initial velocity is halved, the new maximum height of the projectile is _____ m.

Ans. (16)

Sol. $H_{\max} = \frac{u^2 \sin^2 \theta}{2g}$

$$\frac{H_{1\max}}{H_{2\max}} = \frac{u_1^2}{u_2^2}$$

$$\frac{64}{H_{2\max}} = \frac{u^2}{(u/2)^2}$$

$$H_{2\max} = 16 \text{ m}$$

59. A wire of resistance 20Ω is divided into 10 equal parts. A combination of two parts are connected in parallel and so on. Now resulting pairs of parallel combination are connected in series. The equivalent resistance of final combination is _____ Ω .

Ans. (5)

Sol.

$$\frac{20\Omega}{10} \Rightarrow 10 \text{ equal part}$$

Each part has resistance = 2Ω

2 parts are connected in parallel so, $R = 1\Omega$

Now, there will be 5 parts each of resistance 1Ω , they are connected in series.

$$R_{\text{eq}} = 5R, R_{\text{eq}} = 5\Omega$$

60. The current in an inductor is given by $I = (3t + 8)$ where t is in second. The magnitude of induced emf produced in the inductor is 12 mV. The self-inductance of the inductor _____ mH.

Ans. (4)

Sol. $I = 3t + 8$

$$\varepsilon = 12 \text{ mV}$$

$$|\varepsilon| = L \left| \frac{dI}{dt} \right|$$

$$12 = L \times 3$$

$$L = 4 \text{ mH}$$

CHEMISTRY

SECTION-A

61. Match List - I with List - II.

List - I

- (A) ICl
(B) ICl₃
(C) ClF₅

(D) IF₇

List - II

- (I) T-Shape
(II) Square pyramidal
(III) Pentagonal bipyramidal

(IV) Linear

Choose the **correct** answer from the options given below:

- (1) (A)–(I), (B)–(IV), C–(III), D–(II)
(2) (A)–(I), (B)–(III), C–(II), D–(IV)
(3) (A)–(IV), (B)–(I), C–(II), D–(III)
(4) (A)–(IV), (B)–(III), C–(II), D–(I)

Ans. (3)

Sol. A. I – Cl (iv) linear

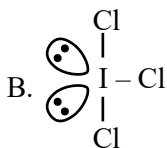

(I) T-shape

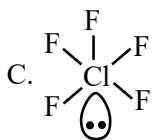

(II) Square pyramidal

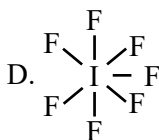

(III) Pentagonal bipyramidal

62. While preparing crystals of Mohr's salt, dil. H₂SO₄ is added to a mixture of ferrous sulphate and ammonium sulphate, before dissolving this mixture in water, dil. H₂SO₄ is added here to:

- (1) prevent the hydrolysis of ferrous sulphate
(2) prevent the hydrolysis of ammonium sulphate
(3) make the medium strongly acidic
(4) increase the rate of formation of crystals

Ans. (1)

TEST PAPER WITH SOLUTION

Sol. Fe⁺² ions undergoes hydrolysis, therefore while preparing aqueous solution of ferrous sulphate and ammonium sulphate in water dilute sulphuric acid is added to prevent hydrolysis of ferrous sulphate.

63. Identify the major product in the following reaction.

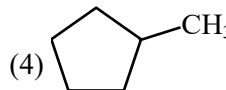
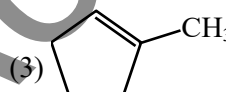
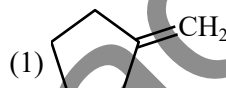
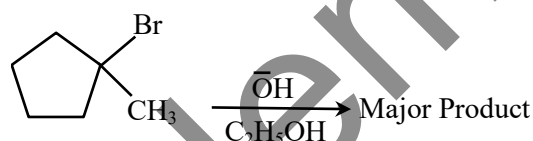

Ans. (3)

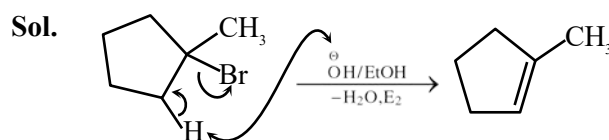

64. The correct nomenclature for the following compound is:

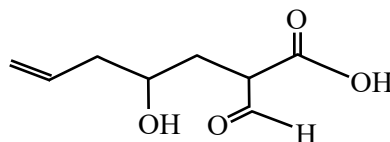

- (1) 2-carboxy-4-hydroxyhept-6-enal
(2) 2-carboxy-4-hydroxyhept-7-enal
(3) 2-formyl-4-hydroxyhept-6-enoic acid
(4) 2-formyl-4-hydroxyhept-7-enoic acid

Ans. (3)

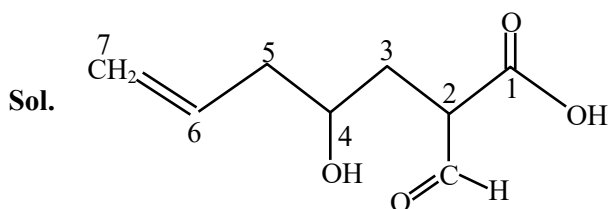

2-formyl-4-hydroxyhept-6-enoic acid

65. Given below are two statements : one is labelled as **Assertion (A)** and the other is labelled as **Reason (R)**.

Assertion (A) : NH_3 and NF_3 molecule have pyramidal shape with a lone pair of electrons on nitrogen atom. The resultant dipole moment of NH_3 is greater than that of NF_3 .

Reason (R) : In NH_3 , the orbital dipole due to lone pair is in the same direction as the resultant dipole moment of the N–H bonds. F is the most electronegative element.

In the light of the above statements, choose the **correct** answer from the options given below:

- (1) Both (A) and (R) are true and (R) is the correct explanation of (A)
- (2) (A) is false but (R) is true
- (3) (A) is true but (R) is false
- (4) Both (A) and (R) are true but (R) is NOT the correct explanation of (A)

Ans. (1)



Resultant dipole moment = 0.80×10^{-30} Cm

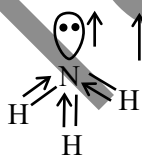

Resultant dipole moment = 4.90×10^{-30} cm

66. Given below are two statements:

Statement I : On passing $\text{HCl}_{(g)}$ through a saturated solution of BaCl_2 , at room temperature white turbidity appears.

Statement II : When HCl gas is passed through a saturated solution of NaCl , sodium chloride is precipitated due to common ion effect.

In the light of the above statements, choose the **most appropriate** answer from the options given below:

- (1) **Statement I** is correct but **Statement II** is incorrect
- (2) Both **Statement I** and **Statement II** are incorrect
- (3) **Statement I** is incorrect but **Statement II** is correct
- (4) Both **Statement I** and **Statement II** are correct

Ans. (1)

Sol. BaCl_2 , NaCl are soluble but on adding $\text{HCl}_{(g)}$ to BaCl_2 , NaCl solutions, Sodium or Barium chlorides may precipitate out, as a consequence of the law of mass action.

67. The metal atom present in the complex MABXL (where A, B, X and L are unidentate ligands and M is metal) involves sp^3 hybridization. The number of geometrical isomers exhibited by the complex is:

- (1) 4
- (2) 0
- (3) 2
- (4) 3

Ans. (2)

Sol. Tetrahedral complex does not show geometrical isomerism.

68. Match List - I with List - II.

List - I (Pair of Compounds)	List - II (Isomerism)
(A) n-propanol and Isopropanol	(I) Metamerism
(B) Methoxypropane and ethoxyethane	(II) Chain Isomerism
(C) Propanone and propanal	(III) Position Isomerism
(D) Neopentane and Isopentane	(IV) Functional Isomerism

- (1) (A)–(II), (B)–(I), (C)–(IV), (D)–(III)
- (2) (A)–(III), (B)–(I), (C)–(II), (D)–(IV)
- (3) (A)–(I), (B)–(III), (C)–(IV), (D)–(II)
- (4) (A)–(III), (B)–(I), (C)–(IV), (D)–(II)

Ans. (4)

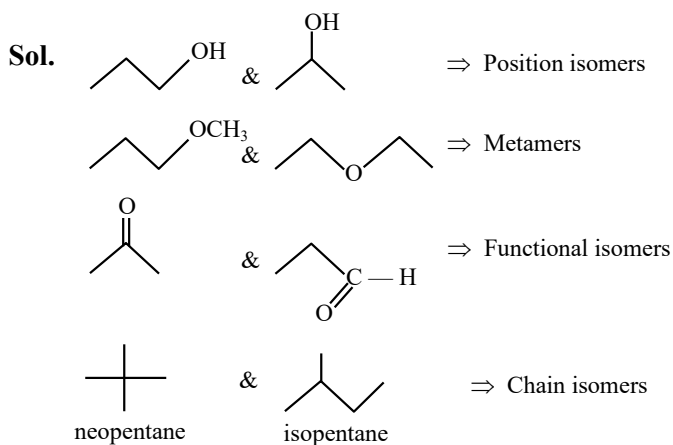

- 69.** The quantity of silver deposited when one coulomb charge is passed through AgNO_3 solution:
- (1) 0.1 g atom of silver
 - (2) 1 chemical equivalent of silver
 - (3) 1 g of silver
 - (4) 1 electrochemical equivalent of silver

Ans. (4)

Sol. $W = ZIt$

$W = ZQ$

$Q = \frac{W}{Z}$

$W = ZQ = (\text{electrochemical equivalent})$

- 70.** Which one of the following reactions is NOT possible?

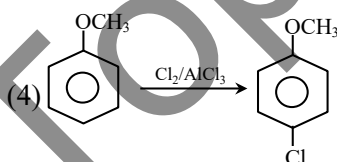
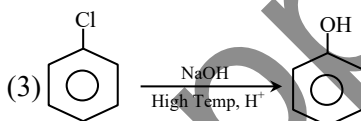
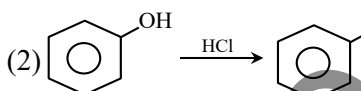
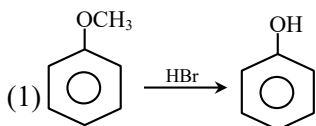

Ans. (2)

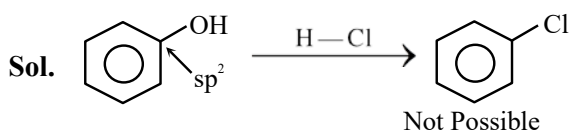

- 71.** Given below are two statements :

Statement I : The metallic radius of Na is 1.86 \AA and the ionic radius of Na^+ is lesser than 1.86 \AA .

Statement II : Ions are always smaller in size than the corresponding elements.

In the light of the above statements, choose the **correct** answer from the options given below :

- (1) **Statement I** is correct but **Statement II** is false
- (2) Both **Statement I** and **Statement II** are true
- (3) Both **Statement I** and **Statement II** are false
- (4) **Statement I** is incorrect but **Statement II** is true

Ans. (1)

Sol. $r_{\text{Na}} > r_{\text{Na}^+}$

So, Statement (I) is correct but size of anions are greater than size of neutral atoms.

So statement (II) is incorrect.

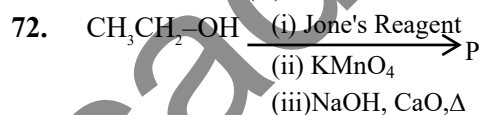

Consider the above reaction sequence and identify the major product P.

- (1) Methane
- (2) Methanal
- (3) Methoxymethane
- (4) Methanoic acid

Ans. (1)

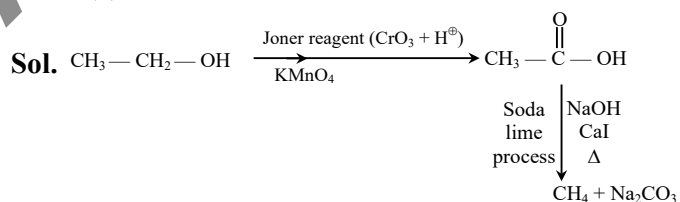

- 73.** Consider the given chemical reaction :

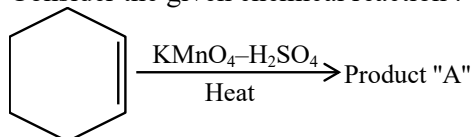

Product "A" is :

- (1) picric acid
- (2) oxalic acid
- (3) acetic acid
- (4) adipic acid

Ans. (4)

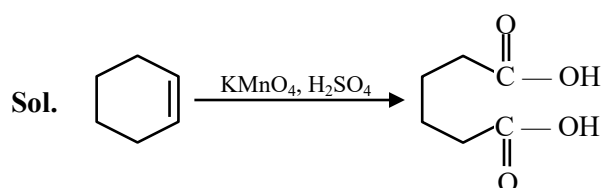

74. For the electro chemical cell
 $M|M^{2+}||X|X^{2-}$
 If $E^0_{(M^{2+}/M)} = 0.46\text{ V}$ and $E^0_{(X/X^{2-})} = 0.34\text{ V}$.

Which of the following is **correct** ?

- (1) $E_{\text{cell}} = -0.80\text{ V}$
 (2) $M + X \rightarrow M^2 + X^{2-}$ is a spontaneous reaction
 (3) $M^{2+} + X^{2-} \rightarrow M + X$ is a spontaneous reaction
 (4) $E_{\text{cell}} = 0.80\text{ V}$

Ans. (3)

Sol. $M | M^{2+} || X / X^{2-}$

$$E_{\text{cell}}^0 = E^0_{M/M^{2+}} + E^0_{X/X^{2-}}$$

$$= -0.46 + 0.34 = -0.12\text{ V}$$

As E_{cell}^0 is negative so anode becomes cathode and cathode become anode. Spontaneous reaction will be
 $M^{2+} + X^{2-} \rightarrow M + X$

75. The number of moles of methane required to produce 11g $\text{CO}_2(\text{g})$ after complete combustion is:
 (Given molar mass of methane in g mol^{-1} : 16)
 (1) 0.75 (2) 0.25
 (3) 0.35 (4) 0.5

Ans. (2)

Sol. $\text{C}_n\text{H}_{2n+2} + \frac{3n+1}{2}\text{O}_2 \rightarrow n\text{CO}_2 + (n+1)\text{H}_2\text{O}$

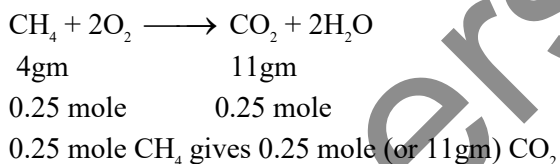

76. The number of complexes from the following with no electrons in the t_2 orbital is _____.

TiCl_4 , $[\text{MnO}_4]^-$, $[\text{FeO}_4]^{2-}$, $[\text{FeCl}_4]^-$, $[\text{CoCl}_4]^{2-}$

- (1) 3 (2) 1
 (3) 4 (4) 2

Ans. (1)

Sol. $\text{TiCl}_4 \Rightarrow \text{Ti}^{+4} \quad e^0 t_2^0$

$\text{MnO}_4^- \Rightarrow \text{Mn}^{+7} \quad e^0 t_2^0$

$\text{FeO}_4^{2-} \Rightarrow \text{Fe}^{+6} \quad e^2 t_2^0$

$\text{FeCl}_4^{2-} \Rightarrow \text{Fe}^{+2} \quad e^3 t_2^3$

$\text{CoCl}_4^{2-} \Rightarrow \text{Co}^{+2} \quad e^4 t_2^3$

77. The number of ions from the following that have the ability to liberate hydrogen from a dilute acid is _____. Ti^{2+} , Cr^{2+} and V^{2+}

- (1) 0 (2) 2
 (3) 3 (4) 1

Ans. (3)

Sol. The ions Ti^{2+} , V^{2+} , Cr^{2+} are strong reducing agents and will liberate hydrogen from a dilute acid, eg.

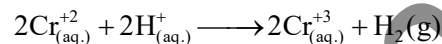

78. Identify A and B in the given chemical reaction sequence :-

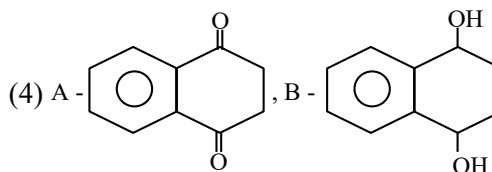
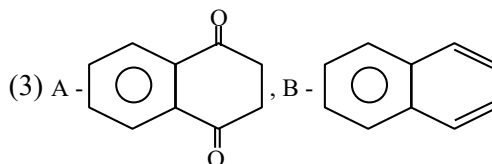
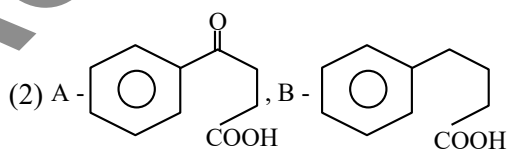
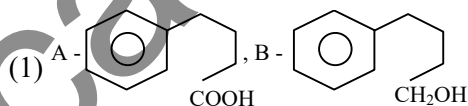
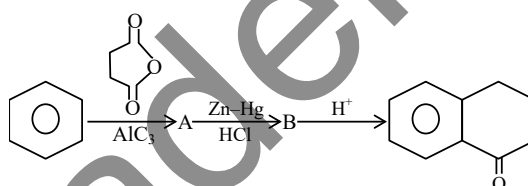

Ans. (2)

Sol.

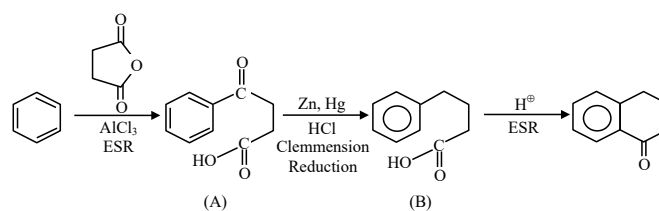

79. The correct statements from the following are :

- (A) The decreasing order of atomic radii of group 13 elements is $Tl > In > Ga > Al > B$.
- (B) Down the group 13 electronegativity decreases from top to bottom.
- (C) Al dissolves in dil. HCl and liberate H_2 but conc. HNO_3 renders Al passive by forming a protective oxide layer on the surface.
- (D) All elements of group 13 exhibits highly stable +1 oxidation state.
- (E) Hybridisation of Al in $[Al(H_2O)_6]^{3+}$ ion is sp^3d^2 .

Choose the **correct** answer from the options given below :

- (1) (C) and (E) only
- (2) (A), (C) and (E) only
- (3) (A), (B), (C) and (E) only
- (4) (A) and (C) only

Ans. (1)

Sol. A. size order $Tl > In > Al > Ga > B$

B. Electronegativity order $B > Al < Ga < In < Tl$

D. B, Al are more stable in +3 oxidation state

So, only C, E statements are correct.

80. Coagulation of egg, on heating is because of :

- (1) Denaturation of protein occurs
- (2) The secondary structure of protein remains unchanged
- (3) Breaking of the peptide linkage in the primary structure of protein occurs
- (4) Biological property of protein remains unchanged

Ans. (1)

Sol. Coagulation of egg give primary structure of protein, which is known as denaturation of protein

SECTION-B

81. Combustion of 1 mole of benzene is expressed at

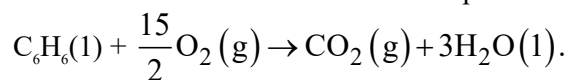

The standard enthalpy of combustion of 2 mol of benzene is $-x$ kJ.

$x =$ _____.

(1) standard Enthalpy of formation of 1 mol of $C_6H_6(l)$, for the reaction

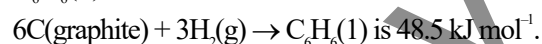

(2) Standard Enthalpy of formation of 1 mol of $CO_2(g)$, for the reaction



(3) Standard and Enthalpy of formation of 1 mol of $H_2O(l)$, for the reaction

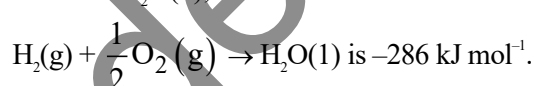

Ans. (6535)

Sol. $6C(\text{graphite}) + 3H_2(g) \rightarrow C_6H_6(l); \Delta H = 48.5 \text{ kJ/mol}$

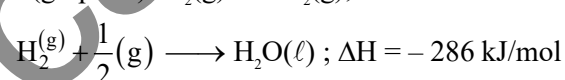
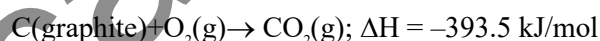

equation $-(1) \times 1 + (2) \times 6 + (3) \times 3$

$$-48.5 - 6 \times 393.5 - 3 \times 286$$

$$= -3267.5 \text{ kJ for 1 mol}$$

$$= -6535 \text{ kJ for 2 mol}$$

Ans. 6535 kJ

82. The fusion of chromite ore with sodium carbonate in the presence of air leads to the formation of products A and B along with the evolution of CO_2 . The sum of spin-only magnetic moment values of A and B is ___ B.M. (Nearest integer)

(Given atomic number : C : 6, Na : 11, O : 8, Fe : 26, Cr : 24]

Ans. (6)

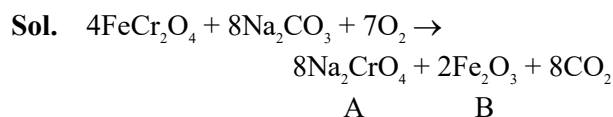

Spin only magnetic moment

$$\text{For } Na_2CrO_4 \quad \mu_B = 0$$

$$\text{For } Fe_2O_3 \quad \mu_B = 5.9$$

$$\text{sum} = 5.9$$

83. X of ethanamine was subjected to reaction with NaNO_2/HCl followed by hydrolysis to liberate N_2 and HCl . The HCl generated was completely neutralised by 0.2 moles of NaOH . X is ____ g.

Ans. (9)

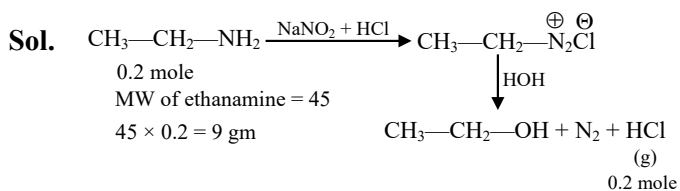

84. In an atom, total number of electrons having quantum numbers $n = 4$, $|m_l| = 1$ and $m_s = -\frac{1}{2}$ is

Ans. (6)

Sol. $n = 4$

l m_l

0 0

1 -1, 0, +1

2 -2, -1, 0, +1, +2, +3

So number of orbital associated with

$n = 4$, $|m_l| = 1$ are 6

Now each orbital contain one e^- with $m_s = -\frac{1}{2}$

85. Using the given figure, the ratio of R_f values of sample A and sample C is $x \times 10^{-2}$. Value of x is

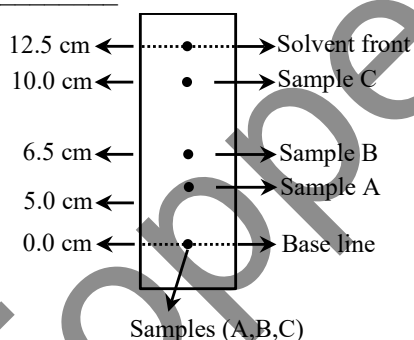
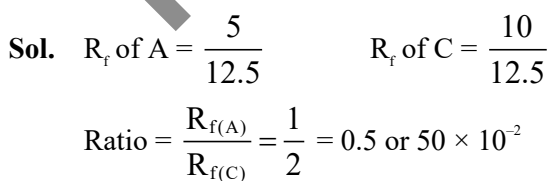

Fig. Paper chromatography of Samples

Ans. (50)



86. In the Claisen-Schmidt reaction to prepare 351 g of dibenzalacetone using 87 g of acetone, the amount of benzaldehyde required is _____ g. (Nearest integer)

Ans. (318)

Sol. Claisen Schmidt reaction

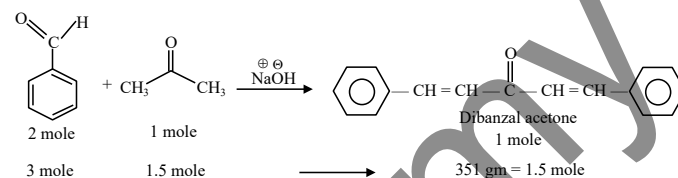

mw of benzaldehyde = 106

$106 \times 3 = 318 \text{ gm}$. Benzaldehyde is required to give 1.5 mole (or 351 gm) product

87. Consider the following single step reaction in gas phase at constant temperature.



The initial rate of the reaction is recorded as r_1 when the reaction starts with 1.5 atm pressure of A and 0.7 atm pressure of B. After some time, the rate r_2 is recorded when the pressure of C becomes 0.5 atm. The ratio $r_1 : r_2$ is _____ $\times 10^{-1}$. (Nearest integer)

Ans. (315)

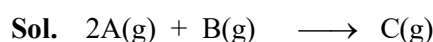

r_1 1.5 atm 0.7 atm

r_2 0.5 atm 0.2 atm 0.5 atm

$$\therefore r = K [P_A]^2 [P_B]$$

$$r_1 = K [1.5]^2 [0.7]$$

$$r_2 = K [0.5]^2 [0.2]$$

$$\frac{r_1}{r_2} = 9 \times \frac{7}{2} = 31.5 = 315 \times 10^{-1}$$

Ans. 315

88. The product © in the following sequence of reactions has _____ π bonds.

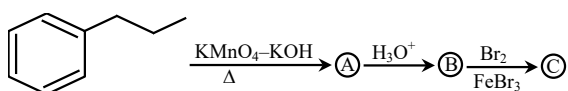

Ans. (4)

Sol. A =

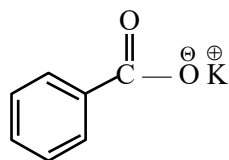

B =

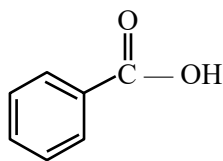

C =

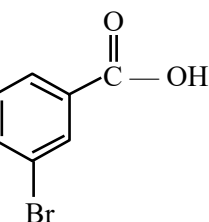

π bonds = 4

89. Considering acetic acid dissociates in water, its dissociation constant is 6.25×10^{-5} . If 5 mL of acetic acid is dissolved in 1 litre water, the solution will freeze at $-x \times 10^{-2} \text{ }^\circ\text{C}$, provided pure water freezes at $0 \text{ }^\circ\text{C}$.

$x =$ _____ . (Nearest integer)

Given : $(K_f)_{\text{water}} = 1.86 \text{ K kg mol}^{-1}$.

density of acetic acid is 1.2 g mol^{-1}

molar mass of water = 18 g mol^{-1} .

molar mass of acetic acid = 60 g mol^{-1} .

density of water = 1 g cm^{-3}

Acetic acid dissociates as

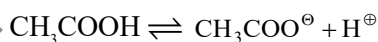

Ans. (19)

Sol. Mass of $\text{CH}_3\text{COOH} = V \times d$
 $= 5 \text{ ml} \times 1.2 \text{ g/ml}$
 $= 6 \text{ gm}$

$$n_{\text{CH}_3\text{COOH}} = \frac{6}{60} = 0.1 \text{ mol}$$

$$m_{\text{CH}_3\text{COOH}} \approx M_{\text{CH}_3\text{COOH}} = \frac{0.1}{1} = 0.1 \text{ M}$$

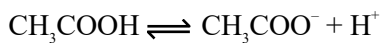

C

C - C_α C_α C_α

$$K_a = \frac{C\alpha^2}{1-\alpha}$$

$$1 - \alpha \approx 1 \Rightarrow K_a = C\alpha^2$$

$$\alpha = \sqrt{\frac{K_a}{C}} = \sqrt{\frac{6.25 \times 10^{-5}}{0.1}} = 25 \times 10^{-3}$$

$$\text{V.f. (i)} = 1 + \alpha(n-1) = 1 + \alpha(2-1) = 1 + \alpha$$

$$= 1 + 25 \times 10^{-3} = 1.025$$

$$\Delta T_f = iK_f m$$

$$= (1.025)(1.86)(0.1)$$

$$= 0.19$$

$$= 19 \times 10^{-2}$$

90. Number of compounds from the following with zero dipole moment is _____.

HF, H_2 , H_2S , CO_2 , NH_3 , BF_3 , CH_4 , CHCl_3 , SiF_4 , H_2O , BeF_2

Ans. (6)

Sol. H_2 , CO_2 , BF_3 , CH_4 , SiF_4 , BeF_2

are symm. molecule so dipole moment is zero

FINAL JEE-MAIN EXAMINATION – APRIL, 2024

(Held On Saturday 06th April, 2024)

TIME : 9 : 00 AM to 12 : 00 NOON

MATHEMATICS

TEST PAPER WITH SOLUTION

SECTION-A

1. If $f(x) = \begin{cases} x^3 \sin\left(\frac{1}{x}\right), & x \neq 0 \\ 0, & x = 0 \end{cases}$, then

(1) $f''(0) = 1$ (2) $f''\left(\frac{2}{\pi}\right) = \frac{24 - \pi^2}{2\pi}$

(3) $f''\left(\frac{2}{\pi}\right) = \frac{12 - \pi^2}{2\pi}$ (4) $f''(0) = 0$

Ans. (2)

Sol. $f(x) = 3x^2 \sin\left(\frac{1}{x}\right) - x \cos\left(\frac{1}{x}\right)$

$$f'(x) = 6x \sin\left(\frac{1}{x}\right) - 3 \cos\left(\frac{1}{x}\right) - \cos\left(\frac{1}{x}\right) - \frac{\sin\left(\frac{1}{x}\right)}{x}$$

$$f''\left(\frac{2}{\pi}\right) = \frac{12}{\pi} - \frac{\pi}{2} = \frac{24 - \pi^2}{2\pi}$$

2. If $A(3,1,-1)$, $B\left(\frac{5}{3}, \frac{7}{3}, \frac{1}{3}\right)$, $C(2,2,1)$ and

$D\left(\frac{10}{3}, \frac{2}{3}, \frac{-1}{3}\right)$ are the vertices of a quadrilateral ABCD, then its area is

(1) $\frac{4\sqrt{2}}{3}$ (2) $\frac{5\sqrt{2}}{3}$

(3) $2\sqrt{2}$ (4) $\frac{2\sqrt{2}}{3}$

Ans. (1)

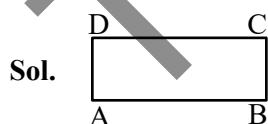

$$\text{Area} = \frac{1}{2} |\overline{BD} \times \overline{AC}|$$

$$\overline{BD} = \frac{5}{3}\hat{i} - \frac{5}{3}\hat{j} - \frac{2}{3}\hat{k}$$

$$\overline{AC} = \hat{i} - \hat{j} - 2\hat{k}$$

3. $\int_0^{\pi/4} \frac{\cos^2 x \sin^2 x}{(\cos^3 x + \sin^3 x)^2} dx$ is equal to

(1) 1/12 (2) 1/9

(3) 1/6 (4) 1/3

Ans. (3)

Sol. Divide Nr & Dr by $\cos x$

$$\int_0^{\pi/4} \frac{\tan^2 x \sec^2 x dx}{(1 + \tan^3 x)^2} dx$$

Let $1 + \tan^3 x = t$

$$\tan^2 x \sec^2 x dx = \frac{dt}{3}$$

$$\frac{1}{3} \int_1^2 \frac{dt}{t^2} = \frac{1}{6}$$

4. The mean and standard deviation of 20 observations are found to be 10 and 2, respectively. On respectively, it was found that an observation by mistake was taken 8 instead of 12. The correct standard deviation is

(1) $\sqrt{3.86}$ (2) 1.8

(3) $\sqrt{3.96}$ (4) 1.94

Ans. (3)

Sol. Mean $(\bar{x}) = 10$

$$\Rightarrow \frac{\sum x_i}{20} = 10$$

$$\sum x_i = 10 \times 20 = 200$$

If 8 is replaced by 12, then $\sum x_i = 200 - 8 + 12 = 204$

$$\therefore \text{Correct mean } (\bar{x}) = \frac{\sum x_i}{20}$$

$$= \frac{204}{20} = 10.2$$

$$\therefore \text{Standard deviation} = 2$$

$$\therefore \text{Variance} = (\text{S.D.})^2 = 2^2 = 4$$

$$\Rightarrow \frac{\sum x_i^2}{20} - \left(\frac{\sum x_i}{20}\right)^2 = 4$$

$$\Rightarrow \frac{\sum x_i^2}{20} - (10)^2 = 4$$

$$\Rightarrow \frac{\sum x_i^2}{20} = 104$$

$$\Rightarrow \sum x_i^2 = 2080$$

Now, replaced '8' observations by '12'

$$\text{Then, } \sum x_i^2 = 2080 - 8^2 + 12^2 = 2160$$

\therefore Variance of removing observations

$$\Rightarrow \frac{\sum x_i^2}{20} - \left(\frac{\sum x_i}{20}\right)^2$$

$$\Rightarrow \frac{2160}{20} - (10.2)^2$$

$$\Rightarrow 108 - 104.04$$

$$\Rightarrow 3.96$$

Correct standard deviation

$$= \sqrt{3.96}$$

5. The function $f(x) = \frac{x^2 + 2x - 15}{x^2 - 4x + 9}$, $x \in \mathbb{R}$ is

(1) both one-one and onto.

(2) onto but not one-one.

(3) neither one-one nor onto.

(4) one-one but not onto.

NTA Ans. (3)

Ans. Bonus

Sol. $f(x) = \frac{(x+5)(x-3)}{x^2 - 4x + 9}$

$$\text{Let } g(x) = x^2 - 4x + 9$$

$$D < 0$$

$$g(x) > 0 \text{ for } x \in \mathbb{R}$$

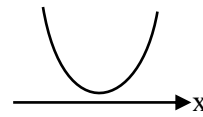

$$\therefore \begin{cases} f(-5) = 0 \\ f(3) = 0 \end{cases}$$

So, $f(x)$ is many-one.

again,

$$yx^2 - 4xy + 9y = x^2 + 2x - 15$$

$$x^2(y-1) - 2x(2y+1) + (9y+15) = 0$$

$$\text{for } \forall x \in \mathbb{R} \Rightarrow D \geq 0$$

$$D = 4(2y+1)^2 - 4(y-1)(9y+15) \geq 0$$

$$5y^2 + 2y + 16 \leq 0$$

$$(5y-8)(y+2) \leq 0$$

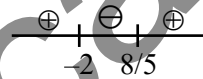

$$y \in \left[-2, \frac{8}{5}\right] \text{ range}$$

Note : If function is defined from $f: \mathbb{R} \rightarrow \mathbb{R}$ then only correct answer is option (3)

\Rightarrow Bonus

6. Let $A = \{n \in [100, 700] \cap \mathbb{N} : n \text{ is neither a multiple of 3 nor a multiple of 4}\}$. Then the number of elements in A is

(1) 300

(2) 280

(3) 310

(4) 290

Ans. (1)

Sol. $n(3) \Rightarrow$ multiple of 3

$$102, 105, 108, \dots, 699$$

$$T_n = 699 = 102 + (n-1)(3)$$

$$n = 200$$

$$n(3) = 200$$

$\therefore n(4) \Rightarrow$ multiple of 4

100, 104, 108, ..., 700

$$T_n = 700 = 100 + (n - 1)(4)$$

$$n = 151$$

$$n(4) = 151$$

$n(3 \cap 4) \Rightarrow$ multiple of 3 & 4 both

108, 120, 132, ..., 696

$$T_n = 696 = 108 + (n - 1)(12)$$

$$n = 50$$

$$n(3 \cap 4) = 50$$

$$n(3 \cup 4) = n(3) + n(4) - n(3 \cap 4)$$

$$= 200 + 151 - 50$$

$$= 301$$

$n(\overline{3 \cup 4}) = \text{Total} - n(3 \cup 4) =$ neither a multiple of 3 nor a multiple of 4

$$= 601 - 301 = 300$$

7. Let C be the circle of minimum area touching the parabola $y = 6 - x^2$ and the lines $y = \sqrt{3}|x|$. Then, which one of the following points lies on the circle C?

(1) (2, 4)

(2) (1, 2)

(3) (2, 2)

(4) (1, 1)

Ans. (1)

Sol.

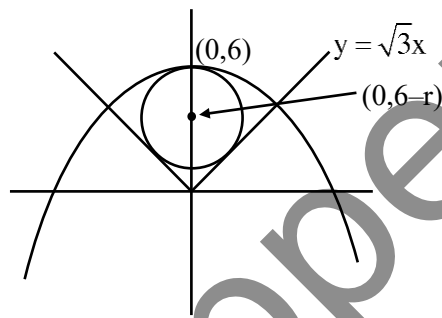

Equation of circle

$$x^2 + (y - (6 - r))^2 = r^2$$

touches $\sqrt{3}x - y = 0$

$$p = r$$

$$\frac{|0 - (6 - r)|}{2} = r$$

$$|r - 6| = 2r$$

$$r = 2$$

$$\therefore \text{Circle } x^2 + (y - 4)^2 = 4$$

(2, 4) Satisfies this equation

8. For $\alpha, \beta \in \mathbb{R}$ and a natural number n , let

$$A_r = \begin{vmatrix} r & 1 & \frac{n^2}{2} + \alpha \\ 2r & 2 & n^2 - \beta \\ 3r - 2 & 3 & \frac{n(3n-1)}{2} \end{vmatrix}. \text{ Then } 2A_{10} - A_8 \text{ is}$$

(1) $4\alpha + 2\beta$

(2) $2\alpha + 4\beta$

(3) $2n$

(4) 0

Ans. (1)

Sol. $A_r = \begin{vmatrix} r & 1 & \frac{n^2}{2} + \alpha \\ 2r & 2 & n^2 - \beta \\ 3r - 2 & 3 & \frac{n(3n-1)}{2} \end{vmatrix}$

$$2A_{10} - A_8 = \begin{vmatrix} 20 & 1 & \frac{n^2}{2} + \alpha \\ 40 & 2 & n^2 - \beta \\ 56 & 3 & \frac{n(3n-1)}{2} \end{vmatrix} - \begin{vmatrix} 8 & 1 & \frac{n^2}{2} + \alpha \\ 16 & 2 & n^2 - \beta \\ 22 & 3 & \frac{n(3n-1)}{2} \end{vmatrix}$$

$$\Rightarrow \begin{vmatrix} 12 & 1 & \frac{n^2}{2} + \alpha \\ 24 & 2 & n^2 - \beta \\ 34 & 3 & \frac{n(3n-1)}{2} \end{vmatrix}$$

$$\Rightarrow \begin{vmatrix} 0 & 1 & \frac{n^2}{2} + \alpha \\ 0 & 2 & n^2 - \beta \\ -2 & 3 & \frac{n(3n-1)}{2} \end{vmatrix}$$

$$\Rightarrow -2((n^2 - \beta) - (n^2 + 2\alpha))$$

$$\Rightarrow -2(-\beta - 2\alpha) \Rightarrow 4\alpha + 2\beta$$

9. The shortest distance between the lines

$$\frac{x-3}{2} = \frac{y+15}{-7} = \frac{z-9}{5} \text{ and } \frac{x+1}{2} = \frac{y-1}{1} = \frac{z-9}{-3} \text{ is}$$

- (1) $6\sqrt{3}$ (2) $4\sqrt{3}$
 (3) $5\sqrt{3}$ (4) $8\sqrt{3}$

Ans. (2)

Sol. $\frac{x-3}{2} = \frac{y+15}{-7} = \frac{z-9}{5}$ & $\frac{x+1}{2} = \frac{y-1}{1} = \frac{z-9}{-3}$

$$S.D = \frac{|(\bar{a}_2 \cdot \bar{a}_1) \cdot (\bar{b}_1 \cdot \bar{b}_2)|}{|\bar{b}_1 \times \bar{b}_2|}$$

$a_1 = 3, -15, 9$ $b_1 = 2, -7, 5$
 $a_2 = -1, 1, 9$ $b_2 = 2, 1, -3$
 $a_2 - a_1 = -4, 16, 0$

$$\bar{b}_1 \times \bar{b}_2 = \begin{vmatrix} \hat{i} & \hat{j} & \hat{k} \\ 2 & -7 & 5 \\ 2 & 1 & -3 \end{vmatrix} = \hat{i}(16) - \hat{j}(-16) + \hat{k}(16)$$

$$16(\hat{i} + \hat{j} + \hat{k})$$

$$|\bar{b}_1 \times \bar{b}_2| = 16\sqrt{3}$$

$$\therefore (\bar{a}_2 - \bar{a}_1) \cdot (\bar{b}_1 - \bar{b}_2) = 16[-4 + 16] = (16)(12)$$

$$S.D. = \frac{(16)(12)}{16\sqrt{3}} = 4\sqrt{3}$$

10. A company has two plants A and B to manufacture motorcycles. 60% motorcycles are manufactured at plant A and the remaining are manufactured at plant B. 80% of the motorcycles manufactured at plant A are rated of the standard quality, while 90% of the motorcycles manufactured at plant B are rated of the standard quality. A motorcycle picked up randomly from the total production is found to be of the standard quality. If p is the probability that it was manufactured at plant B, then 126p is

- (1) 54 (2) 64
 (3) 66 (4) 56

Ans. (1)

Sol.

	A	B
Manufactured	60%	40%
Standard quality	80%	90%

P(Manufactured at B / found standard quality) = ?

A : Found S.Q

B : Manufacture B

C : Manufacture A

$$P(E_1) = \frac{40}{100}$$

$$P(E_2) = \frac{60}{100}$$

$$P(A/E_1) = \frac{90}{100}$$

$$P(A/E_2) = \frac{80}{100}$$

$$\therefore P(E_1/A) = \frac{P(A/E_1) P(E_1)}{P(A/E_1) P(E_1) + P(A/E_2) P(E_2)} = \frac{3}{7}$$

$$\therefore 126P = 54$$

11. Let, α, β be the distinct roots of the equation

$$x^2 - (t^2 - 5t + 6)x + 1 = 0, t \in \mathbb{R} \text{ and } a_n = \alpha^n + \beta^n.$$

Then the minimum value of $\frac{a_{2023} + a_{2025}}{a_{2024}}$ is

- (1) $1/4$ (2) $-1/2$
 (3) $-1/4$ (4) $1/2$

Ans. (3)

Sol. by newton's theorem

$$a_{n+2} - (t^2 - 5t + 6)a_{n+1} + a_n = 0$$

$$\therefore a_{2025} + a_{2023} = (t^2 - 5t + 6) a_{2024}$$

$$\therefore \frac{a_{2025} + a_{2023}}{a_{2024}} = t^2 - 5t + 6$$

$$\therefore t^2 - 5t + 6 = \left(t - \frac{5}{2}\right)^2 - \frac{1}{4}$$

$$\therefore \text{minimum value} = -\frac{1}{4}$$

12. Let the relations R_1 and R_2 on the set $X = \{1, 2, 3, \dots, 20\}$ be given by $R_1 = \{(x, y) : 2x - 3y = 2\}$ and $R_2 = \{(x, y) : -5x + 4y = 0\}$. If M and N be the minimum number of elements required to be added in R_1 and R_2 , respectively, in order to make the relations symmetric, then $M + N$ equals

- (1) 8 (2) 16
(3) 12 (4) 10

Ans. (4)

Sol. $x = \{1, 2, 3, \dots, 20\}$

$$R_1 = \{(x, y) : 2x - 3y = 2\}$$

$$R_2 = \{(x, y) : -5x + 4y = 0\}$$

$$R_1 = \{(4, 2), (7, 4), (10, 6), (13, 8), (16, 10), (19, 12)\}$$

$$R_2 = \{(4, 5), (8, 10), (12, 15), (16, 20)\}$$

in R_1 6 element needed

in R_2 4 element needed

So, total $6+4 = 10$ element

13. Let a variable line of slope $m > 0$ passing through the point $(4, -9)$ intersect the coordinate axes at the points A and B . the minimum value of the sum of the distances of A and B from the origin is

- (1) 25 (2) 30
(3) 15 (4) 10

Ans. (1)

Sol. equation of line is

$$y + 9 = m(x - 4)$$

$$\therefore A = \left(\frac{9+4m}{m}, 0 \right)$$

$$B = (0, -9 - 4m)$$

$$\therefore OA + OB = \frac{9+4m}{m} + 9 + 4m$$

$$\therefore m > 0$$

$$= 13 + \frac{9}{m} + 4m$$

$$\therefore \frac{4m + \frac{9}{m}}{2} \geq \sqrt{36} \Rightarrow 4m + \frac{9}{m} \geq 12$$

$$\therefore OA + OB \geq 25$$

14. The interval in which the function $f(x) = x^x, x > 0$, is strictly increasing is

(1) $\left(0, \frac{1}{e}\right]$ (2) $\left[\frac{1}{e^2}, 1\right)$

(3) $(0, \infty)$ (4) $\left[\frac{1}{e}, \infty\right)$

Ans. (4)

Sol. $f(x) = x^x, x > 0$

$$\ln y = x \ln x$$

$$\frac{1}{y} \frac{dy}{dx} = \frac{x}{x} + \ln x$$

$$\frac{dy}{dx} = x^x (1 + \ln x)$$

for strictly increasing

$$\frac{dy}{dx} \geq 0 \Rightarrow x^x (1 + \ln x) \geq 0$$

$$\Rightarrow \ln x \geq -1$$

$$x \geq e^{-1}$$

$$x \geq \frac{1}{e}$$

$$x \in \left[\frac{1}{e}, \infty\right)$$

15. A circle is inscribed in an equilateral triangle of side of length 12. If the area and perimeter of any square inscribed in this circle are m and n , respectively, then $m + n^2$ is equal to

- (1) 396 (2) 408
 (3) 312 (4) 414

Ans. (2)

Sol. $\therefore r = \frac{\Delta}{s} = \frac{\sqrt{3}a^2}{4 \cdot \frac{3a}{2}} = \frac{a}{2\sqrt{3}} = \frac{12}{2\sqrt{3}} = 2\sqrt{3}$

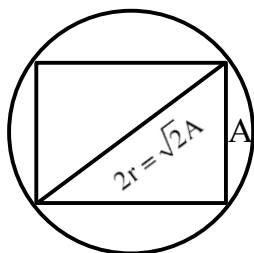

$\therefore A = r\sqrt{2} = 2\sqrt{6}$

Area = $m = A^2 = 24$

Perimeter = $n = 4A = 8\sqrt{6}$

$\therefore m + n^2 = 24 + 384 = 408$

16. The number of triangles whose vertices are at the vertices of a regular octagon but none of whose sides is a side of the octagon is

- (1) 24 (2) 56
 (3) 16 (4) 48

Ans. (3)

Sol. \therefore no. of triangles having no side common with a

sided polygon = $\frac{{}^n C_1 \cdot {}^{n-4} C_2}{3}$

= $\frac{{}^8 C_1 \cdot {}^4 C_2}{3} = 16$

17. Let $y = y(x)$ be the solution of the differential equation $(1+x^2)\frac{dy}{dx} + y = e^{\tan^{-1}x}$, $y(1) = 0$. Then $y(0)$ is

- (1) $\frac{1}{4}(e^{\pi/2} - 1)$ (2) $\frac{1}{2}(1 - e^{\pi/2})$
 (3) $\frac{1}{4}(1 - e^{\pi/2})$ (4) $\frac{1}{2}(e^{\pi/2} - 1)$

Ans. (2)

Sol. $\frac{dy}{dx} + \frac{y}{1+x^2} = \frac{e^{\tan^{-1}x}}{1+x^2}$

I.F. = $e^{\int \frac{1}{1+x^2} dx} = e^{\tan^{-1}x}$

$y \cdot e^{\tan^{-1}x} = \int \left(\frac{e^{\tan^{-1}x}}{1+x^2} \right) e^{\tan^{-1}x} dx$

Let $\tan^{-1}x = z \quad \therefore \frac{dx}{1+x^2} = dz$

$\therefore y \cdot e^z = \int e^{2z} dz = \frac{e^{2z}}{2} + C$

$y \cdot e^{\tan^{-1}x} = \frac{e^{2 \tan^{-1}x}}{2} + C$

$\Rightarrow y = \frac{e^{\tan^{-1}x}}{2} + \frac{C}{e^{\tan^{-1}x}}$

$\therefore y(1) = 0 \Rightarrow 0 = \frac{e^{\pi/4}}{2} + \frac{C}{e^{\pi/4}} \Rightarrow C = \frac{-e^{\pi/2}}{2}$

$\therefore y = \frac{e^{\tan^{-1}x}}{2} - \frac{e^{\pi/2}}{2e^{\tan^{-1}x}}$

$\therefore y(0) = \frac{1 - e^{\pi/2}}{2}$

18. Let $y = y(x)$ be the solution of the differential equation $(2x \log_e x) \frac{dy}{dx} + 2y = \frac{3}{x} \log_e x$, $x > 0$ and $y(e^{-1}) = 0$. Then, $y(e)$ is equal to

- (1) $-\frac{3}{2e}$ (2) $-\frac{2}{3e}$
 (3) $-\frac{3}{e}$ (4) $-\frac{2}{e}$

Ans. (3)

Sol. $\frac{dy}{dx} + \frac{y}{x \ln x} = \frac{3}{2x^2}$

\therefore I.F. = $e^{\int \frac{1}{x \ln x} dx} = e^{\ln(\ln x)} = \ln x$

$\therefore y \ln x = \int \frac{3 \ln x}{2x^2} dx$

$= \frac{3 \ln x}{2} \int x^{-2} dx - \int \left(\frac{3}{2x} \cdot \int x^{-2} dx \right) dx$

$= \frac{3 \ln x}{2} \left(-\frac{1}{x} \right) - \int \frac{3}{2x} \left(-\frac{1}{x} \right) dx$

$y \cdot \ln x = \frac{-3 \ln x}{2x} - \frac{3}{2x} + C$

$\therefore y(e^{-1}) = 0$

$\therefore 0(-1) = \frac{3e}{2} - \frac{3e}{2} + C \Rightarrow C = 0$

$\therefore y = \frac{-3 \ln x}{2x} - \frac{3}{2x}$

$\therefore y(e) = \frac{-3}{2e} - \frac{3}{2e} = -\frac{3}{e}$

19. Let the area of the region enclosed by the curves $y = 3x$, $2y = 27 - 3x$ and $y = 3x - x\sqrt{x}$ be A. Then 10 A is equal to

- (1) 184 (2) 154
 (3) 172 (4) 162

Ans. (4)

Sol. $y = 3x$, $2y = 27 - 3x$ & $y = 3x - x\sqrt{x}$

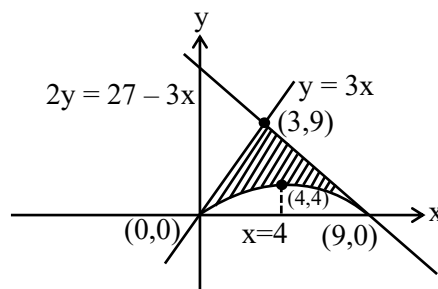

$A = \int_0^3 3x - (3x - x\sqrt{x}) dx + \int_3^9 \left(\frac{27-3x}{2} - (3x - x\sqrt{x}) \right) dx$

$A = \int_0^3 x^{3/2} dx + \int_3^9 \frac{27}{2} - \frac{9x}{2} + x^{3/2} dx$

$A = \left[\frac{2x^{5/2}}{5} \right]_0^3 + \frac{27}{2} [x]_3^9 - \frac{9}{2} \left[\frac{x^2}{2} \right]_3^9 + \left[\frac{2x^{5/2}}{5} \right]_3^9$

$A = \frac{2}{5} (3^{5/2}) + \frac{27}{2} (6) - \frac{9}{4} (72) + \frac{2}{5} (9^{5/2} - 3^{5/2})$

$A = \frac{2}{5} (3^{5/2}) + 81 - 162 + \frac{2}{5} \times 3^5 - \frac{2}{5} \times 3^{5/2}$

$A = \frac{486}{5} - 81 = \frac{81}{5}$

$10A = 162$

Ans. = 4

20. Let $f: (-\infty, \infty) - \{0\} \rightarrow \mathbb{R}$ be a differentiable function such that $f'(1) = \lim_{a \rightarrow \infty} a^2 f\left(\frac{1}{a}\right)$.

Then $\lim_{a \rightarrow \infty} \frac{a(a+1)}{2} \tan^{-1}\left(\frac{1}{a}\right) + a^2 - 2 \log_e a$ is equal

to

- (1) $\frac{3}{2} + \frac{\pi}{4}$ (2) $\frac{3}{8} + \frac{\pi}{4}$
 (3) $\frac{5}{2} + \frac{\pi}{8}$ (4) $\frac{3}{4} + \frac{\pi}{8}$

Ans. (3)

Sol. $f: (-\infty, \infty) - \{0\} \rightarrow \mathbb{R}$

$$f'(1) = \lim_{a \rightarrow \infty} a^2 f\left(\frac{1}{a}\right)$$

$$\lim_{a \rightarrow \infty} \frac{a(a+1)}{2} \tan^{-1}\left(\frac{1}{a}\right) + a^2 - 2\ln(a)$$

$$\lim_{a \rightarrow \infty} a^2 \left(\frac{\left(1 + \frac{1}{a}\right)}{2} \tan^{-1}\left(\frac{1}{a}\right) + 1 - \frac{2}{a^2} \ln(a) \right)$$

$$f(x) = \frac{1}{2}(1+x) \tan^{-1}(x) + 1 - 2x^2 \ln(x)$$

$$f'(x) = \frac{1}{2} \left(\frac{1+x}{1+x^2} + \tan^{-1}(x) + 4x \ln(x) \right) + 2x$$

$$f'(1) = \frac{1}{2} \left(1 + \frac{\pi}{4} \right) + 2$$

$$f'(1) = \frac{5}{2} + \frac{\pi}{8}$$

Ans. (3)

SECTION-B

21. Let $\alpha\beta\gamma = 45$; $\alpha, \beta, \gamma \in \mathbb{R}$. If $x(\alpha, 1, 2) + y(1, \beta, 2) + z(2, 3, \gamma) = (0, 0, 0)$ for some $x, y, z \in \mathbb{R}$, $xyz \neq 0$, then $6\alpha + 4\beta + \gamma$ is equal to _____.

Ans. (55)

Sol. $\alpha\beta\gamma = 45, \alpha, \beta, \gamma \in \mathbb{R}$

$$x(\alpha, 1, 2) + y(1, \beta, 2) + z(2, 3, \gamma) = (0, 0, 0)$$

$$x, y, z \in \mathbb{R}, xyz \neq 0$$

$$\alpha x + y + 2z = 0$$

$$x + \beta y + 3z = 0$$

$$2x + 2y + \gamma z = 0$$

$$xyz \neq 0 \Rightarrow \text{non-trivial}$$

$$\begin{vmatrix} \alpha & 1 & 2 \\ 1 & \beta & 3 \\ 2 & 2 & \gamma \end{vmatrix} = 0$$

$$\Rightarrow \alpha(\beta\gamma - 6) - 1(\gamma - 6) + 2(2 - 2\beta) = 0$$

$$\Rightarrow \alpha\beta\gamma - 6\alpha - \gamma + 6 + 4 - 4\beta = 0$$

$$\Rightarrow 6\alpha + 4\beta + \gamma = 55$$

22. Let a conic C pass through the point $(4, -2)$ and $P(x, y)$, $x \geq 3$, be any point on C. Let the slope of the line touching the conic C only at a single point P be half the slope of the line joining the points P and $(3, -5)$. If the focal distance of the point $(7, 1)$ on C is d, then $12d$ equals _____.

Ans. (75)

Sol. $P(x, y)$ & $x \geq 3$

$$\text{Slope of line at } P(x, y) \text{ will be } \frac{dy}{dx} = \frac{1}{2} \left(\frac{y+5}{x-3} \right)$$

$$\Rightarrow 2 \frac{dy}{(y+5)} = \frac{1}{(x-3)} dx$$

$$\Rightarrow 2\ln(y+5) = \ln(x-3) + C$$

Passes through $(4, -2)$

$$\Rightarrow 2\ln(3) = \ln(1) + C$$

$$\Rightarrow C = 2\ln(3)$$

$$\Rightarrow 2\ln(y+5) = \ln(x-3) + 2\ln(3)$$

$$\Rightarrow 2 \left(\ln \left(\frac{y+5}{3} \right) \right) = \ln(x-3)$$

$$\Rightarrow \left(\frac{y+5}{3} \right)^2 = (x-3)$$

$$\Rightarrow (y+5)^2 = 9(x-3)$$

↓

Parabola

$$4a = 9$$

$$a = \frac{9}{4}$$

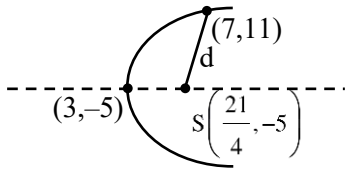

$$d = \sqrt{\left(\frac{7}{4}\right)^2 + 6^2}$$

$$d = \frac{\sqrt{625}}{4}$$

$$d = \frac{25}{4}$$

$$12d = 75$$

23. Let $r_k = \frac{\int_0^1 (1-x^7)^k dx}{\int_0^1 (1-x^7)^{k+1} dx}$, $k \in \mathbb{N}$. Then the value of

$$\sum_{k=1}^{10} \frac{1}{7(r_k - 1)}$$
 is equal to _____.

Ans. (65)

Sol. $I_k = \int_0^1 (1-x^7)^k dx$

$$I_k = (1-x^7)^k x \Big|_0^1 + 7k \int_0^1 (1-x^7)^{k-1} x^6 dx$$

$$I_k = -7k \int_0^1 (1-x^7)^{k-1} ((1-x^7) - 1) dx$$

$$I_k = -7k I_k + 7k I_{k-1}$$

$$\Rightarrow \frac{I_k}{I_{k+1}} = \frac{7k+8}{7k+7}$$

$$r_k = \frac{7k+8}{7k+7}$$

$$r_k - 1 = \frac{1}{7(k+1)}$$

$$\Rightarrow 7(r_k - 1) = \frac{1}{k+1}$$

$$\sum_{k=1}^{10} (k+1) = 11(6) - 1 = 65$$

24. Let x_1, x_2, x_3, x_4 be the solution of the equation

$$4x^4 + 8x^3 - 17x^2 - 12x + 9 = 0 \text{ and}$$

$$(4+x_1^2)(4+x_2^2)(4+x_3^2)(4+x_4^2) = \frac{125}{16} m.$$

Then the value of m is _____.

Ans. (221)

Sol. $4x^4 + 8x^3 - 17x^2 - 12x + 9$

$$= 4(x-x_1)(x-x_2)(x-x_3)(x-x_4)$$

Put $x = 2i$ & $-2i$

$$64 - 64i + 68 - 24i + 9 = (2i-x_1)(2i-x_2)(2i-x_3)$$

$$(2i-x_4)$$

$$= 141 - 88i \quad \dots\dots(1)$$

$$64 + 64i + 68 + 24i + 9 = 4(-2i-x_1)(-2i-x_2)(-2i-x_3)$$

$$(-2i-x_4)$$

$$= 141 + 88i \quad \dots\dots(2)$$

$$\frac{125}{16} m = \frac{141^2 + 88^2}{16}$$

$$m = 221$$

25. Let L_1, L_2 be the lines passing through the point

$P(0, 1)$ and touching the parabola

$$9x^2 + 12x + 18y - 14 = 0.$$
 Let Q and R be the

points on the lines L_1 and L_2 such that the ΔPQR

is an isosceles triangle with base QR . If the slopes

of the lines QR are m_1 and m_2 . then $16(m_1^2 + m_2^2)$

is equal to _____.

Ans. (68)

Sol. $9x^2 + 12x + 4 = -18(y-1)$

$$(3x+2)^2 = -18(y-1)$$

$$\left(x + \frac{2}{3}\right)^2 = -2(y-1)$$

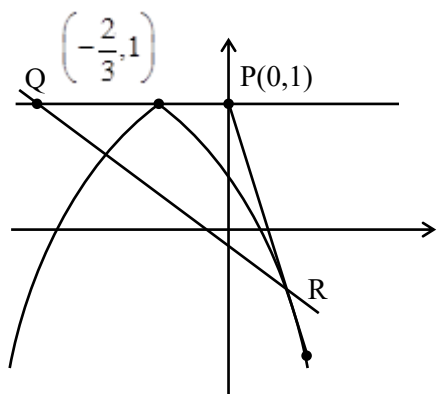

(0, 1)

$$y = mx + 1$$

$$\left(x + \frac{2}{3}\right)^2 = -2(y - 1)$$

$$(3x + 2)^2 = -18mx$$

$$9x^2 + (12 + 18m)x + 4 = 0$$

$$4(6 + 9m)^2 = 4(36)$$

$$6 + 9m = 6, -6$$

$$m = 0, \frac{-4}{3}$$

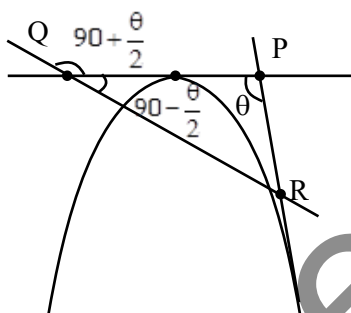

$$\tan \theta = -\frac{4}{3}$$

$$\frac{2 \tan \frac{\theta}{2}}{1 - \tan^2 \frac{\theta}{2}} = \frac{-4}{3}$$

$$\left(\tan \frac{\theta}{2} - 2\right)\left(2 \tan \frac{\theta}{2} + 1\right) = 0$$

$$\tan \frac{\theta}{2} = 2, \frac{-1}{2}$$

$$m_{QR} = \tan\left(90 + \frac{\theta}{2}\right)$$

$$= -\cot \frac{\theta}{2}$$

$$m_1 = \frac{-1}{2}$$

$$m_2 = \frac{-1}{-1/2} = 2$$

$$16(m_1^2 + m_2^2) = 16\left(\frac{1}{4} + 4\right)$$

$$= 4 + 64 = 68$$

26. If the second, third and fourth terms in the expansion of $(x + y)^n$ are 135, 30 and $\frac{10}{3}$, respectively, then $6(n^3 + x^2 + y)$ is equal to _____.

Ans. (806)

Sol. ${}^n C_1 x^{n-1} y = 135$ (i)

$${}^n C_2 x^{n-2} y^2 = 30$$
(ii)

$${}^n C_3 x^{n-3} y^3 = \frac{10}{3}$$
(iii)

By (i)

$$\frac{{}^n C_1 x}{{}^n C_2 y} = \frac{9}{2}$$
(iv)

By (ii)

$$\frac{{}^n C_2 x}{{}^n C_3 y} = 9$$
(v)

By (iv)

$$\frac{{}^n C_1 {}^n C_3}{{}^n C_2 {}^n C_2} = \frac{1}{2}$$

$$\frac{2n^2(n-1)(n-2)}{6} = \frac{n(n-1)}{2} \cdot \frac{n(n-1)}{2}$$

$$4n - 8 = 3n - 3$$

$$\Rightarrow \boxed{n = 5}$$

put in (v)

$$\frac{x}{y} = 9$$

$$x = 9y$$

put in (i)

$${}^5C_1 x^4 \left(\frac{x}{9}\right) = 135$$

$$x^5 = 27 \times 9$$

$$\Rightarrow x = 3, \quad y = \frac{1}{3}$$

$$6(n^3 + x^2 + y)$$

$$= 6\left(125 + 9 + \frac{1}{3}\right)$$

$$= 806$$

27. Let the first term of a series be $T_1 = 6$ and its r^{th} term $T_r = 3T_{r-1} + 6^r$, $r = 2, 3, \dots, n$. If the sum of the first n terms of this series is $\frac{1}{5}(n^2 - 12n + 39)$

$(4.6^n - 5.3^n + 1)$. Then n is equal to _____.

Ans. (6)

Sol. $T_r = 3T_{r-1} + 6^r$, $r = 2, 3, 4, \dots, n$

$$T_2 = 3.T_1 + 6^2$$

$$T_2 = 3.6 + 6^2 \quad \dots(1)$$

$$T_3 = 3T_2 + 6^3$$

$$T_3 = 3T_2 + 6^3$$

$$T_3 = 3(3.6 + 6^2) + 6^3$$

$$T_3 = 3^2.6 + 3.6^2 + 6^3 \quad \dots(2)$$

$$T_r = 3^{r-1}.6 + 3^{r-2}.6^2 + \dots + 6^r$$

$$T_r = 3^{r-1} \cdot 6 \left[1 + \frac{6}{3} + \left(\frac{6}{3}\right)^2 + \dots + \left(\frac{6}{3}\right)^{r-1} \right]$$

$$T_r = 3^{r-1} \cdot 6(1 + 2 + 2^2 + \dots + 2^{r-1})$$

$$T_r = 6 \cdot 3^{r-1} \cdot \frac{(1-2^r)}{(-1)}$$

$$T_r = 6.3^{r-1} \cdot (2^r - 1)$$

$$T_r = \frac{6 \cdot 3^r}{3} \cdot (2^r - 1)$$

$$T_r = 2 \cdot (6^r - 3^r)$$

$$S_n = 2 \sum (6^r - 3^r)$$

$$S_n = 2 \cdot \left[\frac{6 \cdot (6^n - 1)}{5} - \frac{3 \cdot (3^n - 1)}{2} \right]$$

$$S_n = 2 \left[\frac{12(6^n - 1) - 15(3^n - 1)}{10} \right]$$

$$S_n = \frac{3}{5} [4.6^4 - 5.3^n + 1]$$

$$\therefore n^2 - 12n + 39 = 3$$

$$n^2 - 12n + 36 = 0$$

$$n = 6$$

28. For $n \in \mathbb{N}$, if $\cot^{-1}3 + \cot^{-1}4 + \cot^{-1}5 + \cot^{-1}n = \frac{\pi}{4}$, then n is equal to _____.

Ans. (47)

Sol. $\cot^{-1}3 + \cot^{-1}4 + \cot^{-1}5 + \cot^{-1}n = \frac{\pi}{4}$

$$\tan^{-1} \frac{1}{3} + \tan^{-1} \frac{1}{4} + \tan^{-1} \frac{1}{5} + \tan^{-1} \frac{1}{n} = \frac{\pi}{4}$$

$$\tan^{-1} \left(\frac{46}{48} \right) + \tan^{-1} \frac{1}{n} = \frac{\pi}{4}$$

$$\tan^{-1} \left(\frac{23}{24} \right) + \tan^{-1} \frac{1}{n} = \frac{\pi}{4}$$

$$\tan^{-1} \frac{1}{n} = \tan^{-1} 1 - \tan^{-1} \frac{23}{24}$$

$$\tan^{-1} \frac{1}{n} = \tan^{-1} \left(\frac{1 - \frac{23}{24}}{1 + \frac{23}{24}} \right)$$

$$\tan^{-1} \frac{1}{n} = \tan^{-1} \left(\frac{1}{\frac{24}{47}} \right)$$

$$\tan^{-1} \frac{1}{n} = \tan^{-1} \frac{1}{47}$$

$$n = 47$$

29. Let P be the point (10, -2, -1) and Q be the foot of the perpendicular drawn from the point R(1, 7, 6) on the line passing through the points (2, -5, 11) and (-6, 7, -5). Then the length of the line segment PQ is equal to _____.

Ans. (13)

Sol.

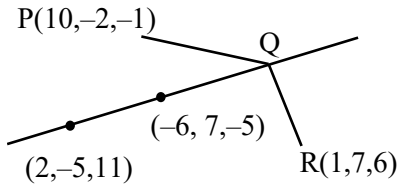

$$\text{Line : } \frac{x+6}{-8} = \frac{y-7}{12} = \frac{z+5}{-16}$$

$$\frac{x+6}{-8} = \frac{y-7}{12} = \frac{z+5}{-16} = \lambda$$

$$Q(2\lambda - 6, 7 - 3\lambda, 4\lambda - 5)$$

$$\overline{QR}(2\lambda - 7, -3\lambda, 4\lambda - 11)$$

$$\overline{QR} \cdot \text{dr's of line} = 0$$

$$4\lambda - 14 + 9\lambda + 16\lambda - 44 = 0$$

$$29\lambda = 58 \Rightarrow \lambda = 2$$

$$Q(-2, 1, 3)$$

$$PQ = \sqrt{144 + 9 + 16} = \sqrt{169} = 13$$

30. Let $\vec{a} = 2\hat{i} - 3\hat{j} + 4\hat{k}$, $\vec{b} = 3\hat{i} + 4\hat{j} - 5\hat{k}$, and a vector \vec{c} be such that $\vec{a} \times (\vec{b} + \vec{c}) + \vec{b} \times \vec{c} = \hat{i} + 8\hat{j} + 13\hat{k}$. If $\vec{a} \cdot \vec{c} = 13$, then $(24 - \vec{b} \cdot \vec{c})$ is equal to _____.

Ans. (46)

Sol. $\vec{a} \times \vec{b} + \vec{a} \times \vec{c} + \vec{b} \times \vec{c} = (1, 8, 13)$

$$\vec{a} \times (\vec{a} \times \vec{b}) + \vec{a} \times (\vec{a} \times \vec{c}) + \vec{a} \times (\vec{b} \times \vec{c})$$

$$= \vec{a} \times (\hat{i} + 8\hat{j} + 13\hat{k})$$

$$(\vec{a} \cdot \vec{b})\vec{a} - a^2\vec{b} + (\vec{a} \cdot \vec{c})\vec{a} - a^2\vec{c} + (\vec{a} \cdot \vec{c})\vec{b} - (\vec{a} \cdot \vec{b})\vec{c} = \vec{a} \times (\hat{i} + 8\hat{j} + 13\hat{k})$$

$$\Rightarrow -26\vec{a} - 29\vec{b} + 13\vec{a} - 29\vec{c} + 13\vec{b} + 26\vec{c} = \vec{a} \times (\hat{i} + 8\hat{j} + 13\hat{k})$$

$$\Rightarrow -13\vec{a} - 16\vec{b} - 3\vec{c} = \vec{a} \times (\hat{i} + 8\hat{j} + 13\hat{k})$$

$$\Rightarrow -13\vec{a} \cdot \vec{b} - 16b^2 - 3\vec{b} \cdot \vec{c} = \left\{ \vec{a} \times (\hat{i} + 8\hat{j} + 13\hat{k}) \right\} \cdot \vec{b}$$

$$\Rightarrow (-13)(-26) - 16(50) - 3\vec{b} \cdot \vec{c} = \begin{vmatrix} 2 & -3 & 4 \\ 1 & 8 & 13 \\ 3 & 4 & -5 \end{vmatrix}$$

$$\Rightarrow -462 - 3\vec{b} \cdot \vec{c} = -396$$

$$\Rightarrow \vec{b} \cdot \vec{c} = -22$$

$$\text{Hence } 24 - \vec{b} \cdot \vec{c} = 46$$

PHYSICS

TEST PAPER WITH SOLUTION

SECTION-A

31. To find the spring constant (k) of a spring experimentally, a student commits 2% positive error in the measurement of time and 1% negative error in measurement of mass. The percentage error in determining value of k is :

- (1) 3% (2) 1%
(3) 4% (4) 5%

Ans. (4)

Sol. $T = 2\pi\sqrt{\frac{m}{k}}$

$$T^2 \propto \frac{m}{k}$$

$$\frac{2\Delta T}{T}\% = \frac{\Delta m}{m}\% - \frac{\Delta k}{k}\%$$

$$\frac{\Delta k}{k}\% = \frac{\Delta m}{m}\% - \frac{2\Delta T}{T}\%$$

$$\frac{\Delta k}{k}\% = (-1)\% - 2(2)\% = |-5\%| = 5\%$$

32. A bullet of mass 50 g is fired with a speed 100 m/s on a plywood and emerges with 40 m/s. The percentage loss of kinetic energy is :

- (1) 32% (2) 44%
(3) 16% (4) 84%

Ans. (4)

Sol. $K_i = \frac{1}{2}m(100)^2$

$$K_f = \frac{1}{2}m(40)^2$$

$$\% \text{loss} = \frac{|K_f - K_i|}{K_i} \times 100$$

$$= \frac{\left| \frac{1}{2}m(40)^2 - \frac{1}{2}m(100)^2 \right|}{\frac{1}{2}m(100)^2} \times 100$$

$$= \frac{|1600 - 100 \times 100|}{100} = 84\%$$

33. The ratio of the shortest wavelength of Balmer series to the shortest wavelength of Lyman series for hydrogen atom is :

- (1) 4 : 1 (2) 1 : 2
(3) 1 : 4 (4) 2 : 1

Ans. (1)

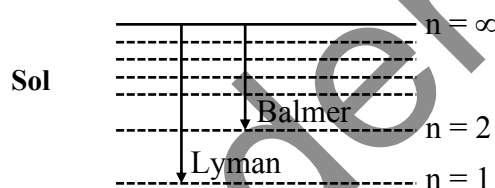

$$\frac{1}{\lambda} = RZ^2 \left(\frac{1}{n_1^2} - \frac{1}{n_2^2} \right)$$

$$\frac{1}{\lambda_L} = RZ^2 \left(\frac{1}{1^2} \right)$$

$$\frac{1}{\lambda_B} = RZ^2 \left(\frac{1}{2^2} \right)$$

$$\frac{\lambda_B}{\lambda_L} = 4 : 1$$

34. To project a body of mass m from earth's surface to infinity, the required kinetic energy is (assume, the radius of earth is R_E , g = acceleration due to gravity on the surface of earth) :

- (1) $2mgR_E$ (2) mgR_E
(3) $\frac{1}{2}mgR_E$ (4) $4mgR_E$

Ans. (2)

Sol. $\frac{1}{2}mv_e^2 = \frac{GMm}{R_E}$

$$g = \frac{GM}{R_E^2}$$

$$K = mgR_E$$

35. Electromagnetic waves travel in a medium with speed of $1.5 \times 10^8 \text{ ms}^{-1}$. The relative permeability of the medium is 2.0. The relative permittivity will be :

- (1) 5 (2) 1
(3) 4 (4) 2

Ans. (4)

Sol.
$$\frac{\epsilon_m \times \mu_m}{\epsilon_0 \times \mu_0} = \frac{1}{v^2}$$

$$\epsilon_r \times \mu_r = \frac{c^2}{v^2}$$

$$\epsilon_r \times 2 = \frac{(3 \times 10^8)^2}{(1.5 \times 10^8)^2}$$

$$\epsilon_r \times 2 = 4$$

$$\epsilon_r = 2$$

36. Which of the following phenomena does not explain by wave nature of light.

- (A) reflection (B) diffraction
(C) photoelectric effect (D) interference
(E) polarization

Choose the **most appropriate** answer from the options given below :

- (1) E only (2) C only
(3) B, D only (4) A, C only

Ans. (2)

Sol. (Theory)

Photoelectric effect prove particle nature of light.

37. While measuring diameter of wire using screw gauge the following readings were noted. Main scale reading is 1 mm and circular scale reading is equal to 42 divisions. Pitch of screw gauge is 1 mm and it has 100 divisions on circular scale. The

diameter of the wire is $\frac{x}{50}$ mm . The value of x is :

- (1) 142 (2) 71
(3) 42 (4) 21

Ans. (2)

Sol. MSR = 1mm, CSR = 42, pitch = 1 mm

$$LC = \frac{\text{pitch}}{\text{No. of CSD}} = \left(\frac{1}{100} \right) = 0.01 \text{mm}$$

Diameter = MSR + LC × CSD

Diameter = 1 + (0.01) × 42 mm

Diameter = 1.42 mm = $\frac{x}{50}$

∴ x = 71

38. σ is the uniform surface charge density of a thin spherical shell of radius R. The electric field at any point on the surface of the spherical shell is :

- (1) $\sigma/\epsilon_0 R$ (2) $\sigma/2\epsilon_0$
(3) σ/ϵ_0 (4) $\sigma/4\epsilon_0$

Ans. (3)

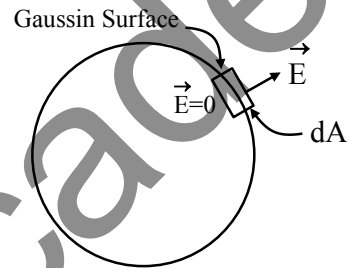

Sol.

By Gauss law
$$\int \vec{E} \cdot d\vec{A} = \frac{q_{in}}{\epsilon_0}$$

$$EdA = \frac{\sigma \times dA}{\epsilon_0}$$

$$E = \frac{\sigma}{\epsilon_0}$$

39. The value of unknown resistance (x) for which the potential difference between B and D will be zero in the arrangement shown, is :

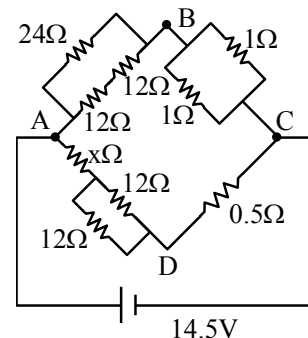

- (1) 3 Ω (2) 9 Ω
(3) 6 Ω (4) 42 Ω

Ans. (3)

Sol.

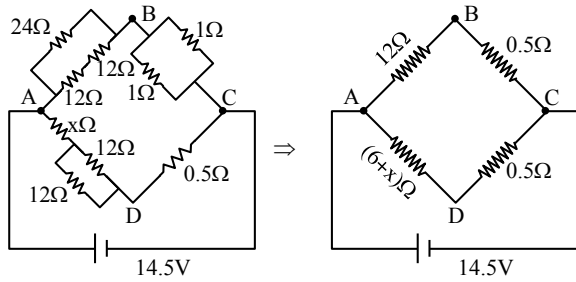

In case of balanced Wheatstone Bridge

$$\frac{V_{AB}}{V_{AD}} = \frac{V_{BC}}{V_{CD}} \Rightarrow \frac{12}{6+x} = \frac{0.5}{0.5}$$

$$x = 6 \Omega$$

40. The specific heat at constant pressure of a real gas obeying $PV^2 = RT$ equation is :

- (1) $C_v + R$ (2) $\frac{R}{3} + C_v$
 (3) R (4) $C_v + \frac{R}{2V}$

Ans. (4)

Sol. $dQ = du + dW$

$$CdT = C_v dT + PdV \quad \dots(1)$$

$$\therefore PV^2 = RT$$

$$P = \text{constant}$$

$$P(2VdV) = RdT$$

$$PdV = \frac{RdT}{2V}$$

Put in equation (1)

$$C = C_v + \frac{R}{2V}$$

41. Match List I with List II

	LIST I		LIST II
A.	Torque	I.	$[M^1L^1T^{-2}A^{-2}]$
B.	Magnetic field	II.	$[L^2A^1]$
C.	Magnetic moment	III.	$[M^1T^{-2}A^{-1}]$
D.	Permeability of free space	IV.	$[M^1L^2T^{-2}]$

Choose the correct answer from the options given below :

- (1) A-I, B-III, C-II, D-IV
 (2) A-IV, B-III, C-II, D-I
 (3) A-III, B-I, C-II, D-IV
 (4) A-IV, B-II, C-III, D-I

Ans. (2)

Sol. $[\vec{\tau}] = [\vec{r} \times \vec{F}] = [ML^2T^{-2}]$

$$[F] = [qVB]$$

$$\Rightarrow B = \left(\frac{F}{qV} \right) = \left[\frac{MLT^{-2}}{ATLT^{-1}} \right] = [MA^{-1}T^{-2}]$$

$$[M] = [I \times A] = [AL^2]$$

$$B = \frac{\mu_0 Idl \sin \theta}{4\pi r^2}$$

$$\Rightarrow [\mu] = \left[\frac{Br^2}{Idl} \right] = \left[\frac{MT^{-2}A^{-1} \times L^2}{AL} \right] = [MLT^{-2}A^{-2}]$$

42. Given below are two statements :

Statement I : In an LCR series circuit, current is maximum at resonance.

Statement II : Current in a purely resistive circuit can never be less than that in a series LCR circuit when connected to same voltage source.

In the light of the above statements, choose the correct from the options given below :

- (1) Statement I is true but Statement II is false
 (2) Statement I is false but Statement II is true
 (3) Both Statement I and Statement II are true
 (4) Both Statement I and Statement II are false

Ans. (3)

Sol. **Statement-I**

$$I_m = \frac{V_m}{\sqrt{R^2 + (X_L - X_C)^2}} \text{ at resonance } X_L = X_C$$

$$\text{Thus, } I_m = \frac{V_m}{R}$$

\therefore Impedence is minimum therefore I is maximum at resonance.

Statement-II

$$I = \left(\frac{V}{R} \right) \text{ in purely resistive circuit.}$$

43. The correct truth table for the following logic circuit is :

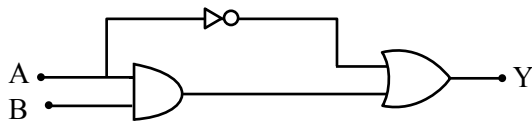

Options :

(1)

A	B	Y
0	0	0
0	1	1
1	0	0
1	1	1

(2)

A	B	Y
0	0	1
0	1	1
1	0	0
1	1	1

(3)

A	B	Y
0	0	1
0	1	1
1	0	0
1	1	0

(4)

A	B	Y
0	0	0
0	1	0
1	0	0
1	1	1

Ans. (2)

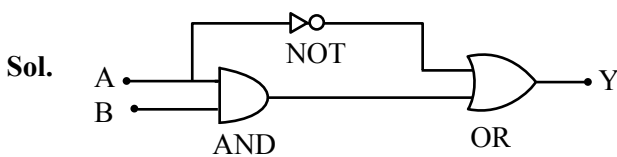

44. A sample contains mixture of helium and oxygen gas. The ratio of root mean square speed of helium and oxygen in the sample, is :

(1) $\frac{1}{32}$

(2) $\frac{2\sqrt{2}}{1}$

(3) $\frac{1}{4}$

(4) $\frac{1}{2\sqrt{2}}$

Ans. (2)

Sol.
$$V_{\text{rms}} = \sqrt{\frac{3RT}{M_w}}$$

$$\Rightarrow \frac{V_{\text{O}_2}}{V_{\text{He}}} = \sqrt{\frac{M_{w,\text{He}}}{M_{w,\text{O}_2}}}$$

$$= \sqrt{\frac{4}{32}} = \frac{1}{2\sqrt{2}}$$

$$\frac{V_{\text{He}}}{V_{\text{O}_2}} = \frac{2\sqrt{2}}{1}$$

45. A light string passing over a smooth light pulley connects two blocks of masses m_1 and m_2 (where $m_2 > m_1$). If the acceleration of the system is $\frac{g}{\sqrt{2}}$, then the ratio of the masses $\frac{m_1}{m_2}$ is :

(1) $\frac{\sqrt{2}-1}{\sqrt{2}+1}$

(2) $\frac{1+\sqrt{5}}{\sqrt{5}-1}$

(3) $\frac{1+\sqrt{5}}{\sqrt{2}-1}$

(4) $\frac{\sqrt{3}+1}{\sqrt{2}-1}$

Ans. (1)

Sol.
$$a = \left(\frac{M_2 - M_1}{M_1 + M_2} \right) g$$

$$\frac{g}{\sqrt{2}} = \left(\frac{M_2 - M_1}{M_1 + M_2} \right) g$$

$$(M_1 + M_2) = \sqrt{2}M_2 - \sqrt{2}M_1$$

$$\frac{M_1}{M_2} = \left(\frac{\sqrt{2}-1}{\sqrt{2}+1} \right)$$

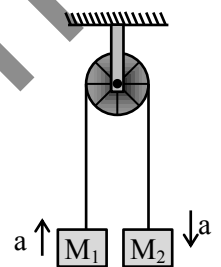

46. Four particles A, B, C, D of mass $\frac{m}{2}$, m , $2m$, $4m$, have same momentum, respectively. The particle with maximum kinetic energy is :

(1) D

(2) C

(3) A

(4) B

Ans. (3)

Sol.
$$KE = \frac{p^2}{2m}$$

Same momentum, so less mass means more KE.

So $\frac{m}{2}$ will have max. KE.

47. A train starting from rest first accelerates uniformly up to a speed of 80 km/h for time t , then it moves with a constant speed for time $3t$. The average speed of the train for this duration of journey will be (in km/h) :

(1) 80

(2) 70

(3) 30

(4) 40

Ans. (2)

Sol. Average speed = $\frac{\text{total distance}}{\text{time taken}}$

$$= \frac{\frac{80 \times t}{2} + 80 \times 3t}{4t} = 70 \text{ km/hr.}$$

48. An element $\Delta l = \Delta x \hat{i}$ is placed at the origin and carries a large current $I = 10\text{A}$. The magnetic field on the y -axis at a distance of 0.5 m from the elements Δx of 1 cm length is :

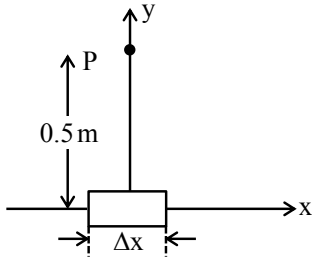

- (1) $4 \times 10^{-8}\text{ T}$ (2) $8 \times 10^{-8}\text{ T}$
 (3) $12 \times 10^{-8}\text{ T}$ (4) $10 \times 10^{-8}\text{ T}$

Ans. (1)

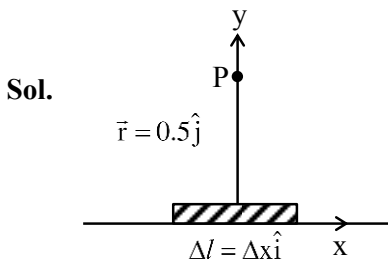

$$\vec{dB} = \frac{\mu_0 I}{4\pi} \frac{(\vec{dl} \times \vec{r})}{r^3} \text{ (Tesla)}$$

$$= \frac{10^{-7} \times 10 \times \left(\frac{1}{2} \times \frac{1}{100}\right) (+\hat{k})}{\left(\frac{1}{2}\right)^3} = 4 \times 10^{-8}\text{ T } (+\hat{k})$$

49. A small ball of mass m and density ρ is dropped in a viscous liquid of density ρ_0 . After sometime, the ball falls with constant velocity. The viscous force on the ball is :

- (1) $mg \left(\frac{\rho_0}{\rho} - 1\right)$ (2) $mg \left(1 + \frac{\rho}{\rho_0}\right)$
 (3) $mg(1 - \rho\rho_0)$ (4) $mg \left(1 - \frac{\rho_0}{\rho}\right)$

Ans. (4)

Sol. $mg - F_B - F_v = ma$
 $a = 0$ for constant velocity
 $mg - F_B = F_v$

$$F_v = mg - v \rho_0 g = mg - \frac{m}{\rho} \rho_0 g = mg \left(1 - \frac{\rho_0}{\rho}\right)$$

50. In photoelectric experiment energy of 2.48 eV irradiates a photo sensitive material. The stopping potential was measured to be 0.5 V . Work function of the photo sensitive material is :

- (1) 0.5 eV (2) 1.68 eV
 (3) 2.48 eV (4) 1.98 eV

Ans. (4)

Sol. $eV_s = hv - \phi$
 $0.5\text{ V} = 2.48 - \phi$
 work function (ϕ) = $2.48\text{ V} - 0.5\text{ V} = 1.98\text{ V}$

SECTION-B

51. If the radius of earth is reduced to three-fourth of its present value without change in its mass then value of duration of the day of earth will be _____ hours 30 minutes.

Ans. (13)

Sol. By conservation of angular momentum

$$I_1 \omega_1 = I_2 \omega_2$$

$$\left(\frac{2}{5} MR^2\right) \frac{2\pi}{T_1} = \frac{2}{5} M \left(\frac{3}{4} R\right)^2 \frac{2\pi}{T_2}$$

$$\frac{1}{T_1} = \frac{9}{16 T_2}$$

$$\frac{1}{T_2} = \frac{9}{16} \times T_1 = \frac{9}{16} \times 24\text{ hr} = \frac{27}{2}\text{ hr} = 13\text{ hr } 30\text{ mins.}$$

52. Three infinitely long charged thin sheets are placed as shown in figure. The magnitude of electric field at the point P is $\frac{x\sigma}{\epsilon_0}$. The value of x is _____

(all quantities are measured in SI units).

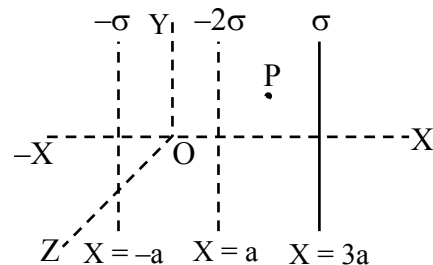

Ans. (2)

Sol.

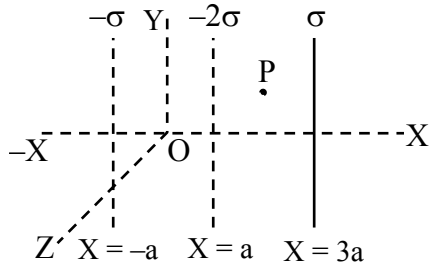

$$\begin{aligned} \vec{E}_p &= \left(\frac{\sigma}{2\epsilon_0} + \frac{2\sigma}{2\epsilon_0} + \frac{\sigma}{2\epsilon_0} \right) (-\hat{i}) \\ &= -\frac{2\sigma}{\epsilon_0} \hat{i} \end{aligned}$$

53. A big drop is formed by coalescing 1000 small droplets of water. The ratio of surface energy of 1000 droplets to that of energy of big drop is $\frac{10}{x}$.

The value of x is _____.

Ans. (1)

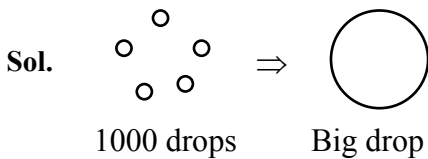

$$\begin{aligned} 1000 \frac{4}{3} \pi r^3 &= \frac{4}{3} \pi R^3 \\ 10r &= R \\ R &= 10r \end{aligned}$$

$$\begin{aligned} \frac{\text{S.E. of 1000 drops}}{\text{S.E. of Big drop}} &= \frac{1000(4\pi r^2)T}{4\pi R^2 T} \\ &= \frac{1000 \times r^2}{(10r)^2} = 10 = \frac{10}{x} \\ \therefore x &= 1 \end{aligned}$$

54. When a dc voltage of 100V is applied to an inductor, a dc current of 5A flows through it. When an ac voltage of 200V peak value is connected to inductor, its inductive reactance is found to be $20\sqrt{3} \Omega$. The power dissipated in the circuit is _____ W.

Ans. (250)

Sol. For DC voltage

$$R = \frac{V}{I} = \frac{100}{5} = 20 \Omega$$

for AC voltage

$$X_L = 20\sqrt{3} \Omega$$

$$R = 20 \Omega$$

$$Z = \sqrt{X_L^2 + R^2} = \sqrt{3 \times 400 + 400} = 40 \Omega$$

$$\text{Power} = i_{\text{rms}}^2 R$$

$$= \left(\frac{V_{\text{rms}}}{Z} \right)^2 \times R = \left(\frac{\frac{200}{\sqrt{2}}}{40} \right)^2 \times 20 = 250 \text{ W}$$

55. The refractive index of prism is $\mu = \sqrt{3}$ and the ratio of the angle of minimum deviation to the angle of prism is one. The value of angle of prism is _____°.

Ans. (60)

Sol. For δ_{\min}

$$i = e$$

$$r_1 = r_2 = \frac{A}{2}$$

$$\frac{\delta_{\min}}{A} = 1$$

$$\frac{2i - A}{A} = 1$$

$$2i = 2A$$

$$i = A$$

Snell's law

$$1 \times \sin i = \mu \sin r$$

$$\sin i = \mu \sin \left(\frac{A}{2} \right)$$

$$\sin A = \mu \sin \left(\frac{A}{2} \right)$$

$$2 \sin \frac{A}{2} \cos \frac{A}{2} = \sqrt{3} \sin \left(\frac{A}{2} \right)$$

$$\cos \left(\frac{A}{2} \right) = \frac{\sqrt{3}}{2}$$

$$\therefore \frac{A}{2} = 30^\circ$$

$$\therefore A = 60^\circ$$

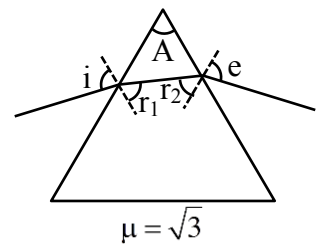

56. A wire of resistance R and radius r is stretched till its radius became $r/2$. If new resistance of the stretched wire is xR , then value of x is _____.

Ans. (16)

Sol. We know $R = \frac{\rho l}{A}$, $R \propto \frac{l}{r^2}$

As we stretch the wire, its length will increase but its radius will decrease keeping the volume constant

$$V_i = V_f$$

$$\pi r^2 l = \pi \frac{r_f^2}{4} l_f$$

$$l_f = 4l$$

$$\frac{R_{\text{new}}}{R_{\text{old}}} = \left(\frac{4l}{\frac{r^2}{4}} \right) \frac{r^2}{l} = 16$$

$$R_{\text{new}} = 16R$$

$$\therefore x = 16$$

57. Radius of a certain orbit of hydrogen atom is 8.48 \AA . If energy of electron in this orbit is E/x , then $x =$ _____.

(Given $a_0 = 0.529 \text{ \AA}$, $E =$ energy of electron in ground state)

Ans. (16)

Sol. We know

$$r = 0.529 \frac{n^2}{Z} \Rightarrow 8.48 = 0.529 \frac{n^2}{1}$$

$$n^2 = 16 \Rightarrow n = 4$$

We know

$$E \propto \frac{1}{n^2}$$

$$E_{n^{\text{th}}} = \frac{E}{16}$$

$$x = 16$$

58. A circular coil having 200 turns, $2.5 \times 10^{-4} \text{ m}^2$ area and carrying $100 \mu\text{A}$ current is placed in a uniform magnetic field of 1 T . Initially the magnetic dipole moment (\vec{M}) was directed along \vec{B} . Amount of work, required to rotate the coil through 90° from its initial orientation such that \vec{M} becomes perpendicular to \vec{B} , is _____ μJ .

Ans. (5)

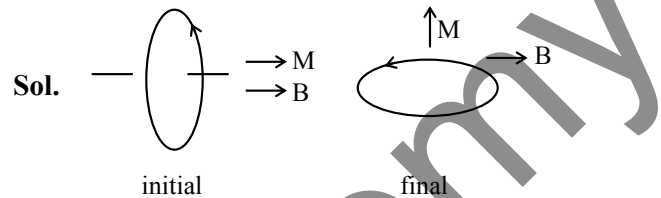

Sol.

We know

$$\begin{aligned} W_{\text{ext}} &= \Delta U + \Delta \text{KE} \quad (\text{P.E.} = -\vec{M} \cdot \vec{B}) \\ &= -\vec{M} \cdot \vec{B}_f + \vec{M} \cdot \vec{B}_i + 0 \\ &= -MB \cos 90^\circ + MB \cos 0^\circ \\ &= MB \\ &= NIAB \\ &= 200 \times 100 \times 10^{-6} \times \frac{5}{2} \times 10^{-4} \times 1 = 5 \mu\text{J} \end{aligned}$$

59. A particle is doing simple harmonic motion of amplitude 0.06 m and time period 3.14 s . The maximum velocity of the particle is _____ cm/s .

Ans. (12)

Sol. We know

$$\begin{aligned} v_{\text{max}} &= \omega A \quad \text{at mean position} \\ &= \frac{2\pi}{T} A = \frac{2\pi}{\pi} \times 0.06 = 0.12 \text{ m/sec} \end{aligned}$$

$$v_{\text{max}} = 12 \text{ cm/sec}$$

60. For three vectors $\vec{A} = (-x\hat{i} - 6\hat{j} - 2\hat{k})$, $\vec{B} = (-\hat{i} + 4\hat{j} + 3\hat{k})$ and $\vec{C} = (-8\hat{i} - \hat{j} + 3\hat{k})$, if $\vec{A} \cdot (\vec{B} \times \vec{C}) = 0$, then value of x is _____.

Ans. (4)

$$\text{Sol. } \vec{B} \times \vec{C} = \begin{vmatrix} \hat{i} & \hat{j} & \hat{k} \\ -1 & 4 & 3 \\ -8 & -1 & 3 \end{vmatrix} = 15\hat{i} - 21\hat{j} + 33\hat{k}$$

$$\vec{A} \cdot (\vec{B} \times \vec{C}) = (-x\hat{i} - 6\hat{j} - 2\hat{k}) \cdot (15\hat{i} - 21\hat{j} + 33\hat{k})$$

$$0 = -15x + 126 - 66$$

$$15x = 60$$

$$x = 4$$

CHEMISTRY

TEST PAPER WITH SOLUTION

SECTION-A

61. Functional group present in sulphonic acid is :

- (1) SO_4H (2) SO_3H
 (3) $\begin{array}{c} \text{O} \\ || \\ -\text{S}-\text{OH} \end{array}$ (4) $-\text{SO}_2$

Ans. (2)

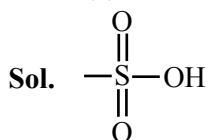

Group present in sulphonic acids

62. Match List I with List II :

List I (Molecule / Species)		List II (Property / Shape)	
A.	SO_2Cl_2	I.	Paramagnetic
B.	NO	II.	Diamagnetic
C.	NO_2^-	III.	Tetrahedral
D.	I_3^-	IV.	Linear

Choose the **correct** answer from the options given below :

- (1) A-IV, B-I, C-III, D-II
 (2) A-III, B-I, C-II, D-IV
 (3) A-II, B-III, C-I, D-IV
 (4) A-III, B-IV, C-II, D-I

Ans. (2)

Sol.

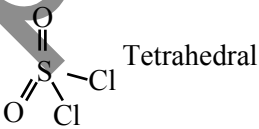
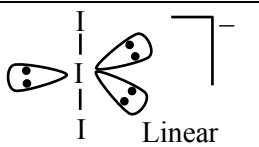
(A)	SO_2Cl_2	sp^3	 Tetrahedral
(B)	NO		Paramagnetic
(C)	NO_2^-		Diamagnetic
(D)	I_3^-	sp^3d	 Linear

63. Given below are two statements :

Statement I : Picric acid is 2, 4, 6-trinitrotoluene.

Statement II : Phenol-2, 4-disulphuric acid is treated with conc. HNO_3 to get picric acid.

In the light of the above statement, choose the **most appropriate** answer from the options given below :

- (1) Statement I is incorrect but Statement II is correct.
 (2) Both Statement I and Statement II are incorrect.
 (3) Statement I is correct but Statement II is incorrect.
 (4) Both Statement I and Statement II are correct.

Ans. (1)

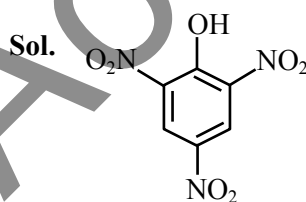

picric acid

(2, 4, 6 – trinitrophenol)

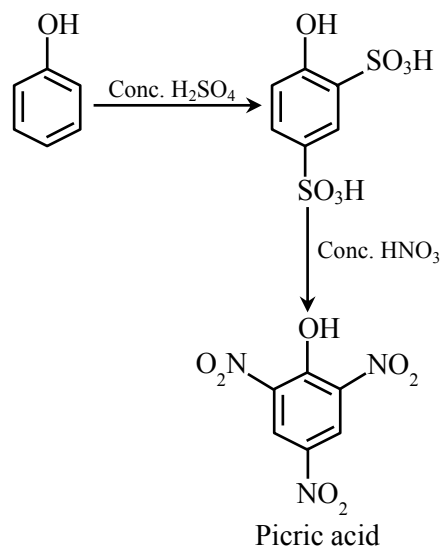

64. Which of the following is metamer of the given compound (X) ?

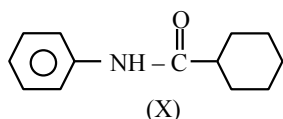

- (1)
- (2)
- (3)
- (4)

Ans. (4)

Sol. Metamer \Rightarrow Isomer having same molecular formula, same functional group but different alkyl/aryl groups on either side of functional group.

65. DNA molecule contains 4 bases whose structure are shown below. One of the structure is not correct, identify the **incorrect** base structure.

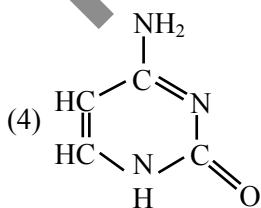
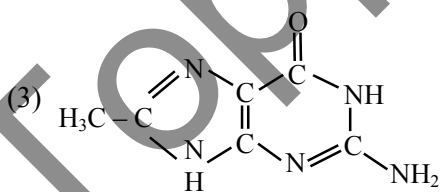
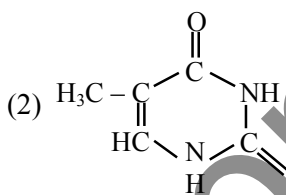
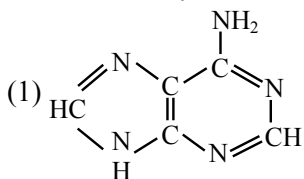

Ans. (3)

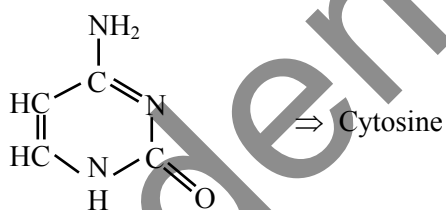
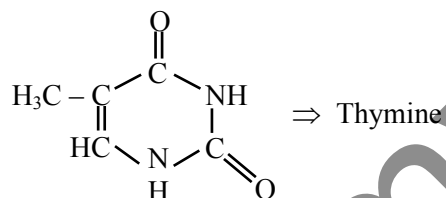
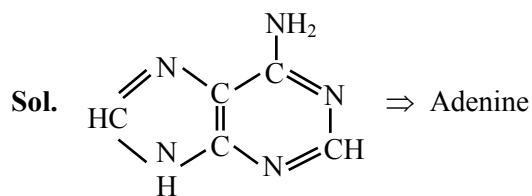

Are bases of DNA molecule. As DNA contain four bases, which are adenine, guanine, cytosine and thymine.

66. Match List I with List II :

LIST I (Hybridization)		LIST II (Orientation in Space)	
A.	sp^3	I.	Trigonal bipyramidal
B.	dsp^2	II.	Octahedral
C.	sp^3d	III.	Tetrahedral
D.	sp^3d^2	IV.	Square planar

Choose the **correct** answer from the options given below :

- (1) A-III, B-I, C-IV, D-II
 (2) A-II, B-I, C-IV, D-III
 (3) A-IV, B-III, C-I, D-II
 (4) A-III, B-IV, C-I, D-II

Ans. (4)

Sol. $sp^3 \rightarrow$ Tetrahedral
 $dsp^2 \rightarrow$ Square planar
 $sp^3d \rightarrow$ Trigonal Bipyramidal
 $sp^3d^2 \rightarrow$ Octahedral

67. Given below are two statements :

Statement I : Gallium is used in the manufacturing of thermometers.

Statement II : A thermometer containing gallium is useful for measuring the freezing point (256 K) of brine solution.

In the light of the above statement, choose the correct answer from the options given below :

- (1) Both Statement I and Statement II are false.
- (2) Statement I is false but Statement II is true.
- (3) Both Statement I and Statement II are true.
- (4) Statement I is true but Statement II is false.

Ans. (4)

Sol. Statement - I \Rightarrow Correct

Statement - II \Rightarrow False

Ga is used to measure high temperature

68. Which of the following statements are correct ?

- A. Glycerol is purified by vacuum distillation because it decomposes at its normal boiling point.
- B. Aniline can be purified by steam distillation as aniline is miscible in water.
- C. Ethanol can be separated from ethanol water mixture by azeotropic distillation because it forms azeotrope.
- D. An organic compound is pure, if mixed M.P. is remained same.

Choose the **most appropriate** answer from the options given below :

- (1) A, B, C only
- (2) A, C, D only
- (3) B, C, D only
- (4) A, B, D only

Ans. (2)

Sol. Option (B) is incorrect because aniline is immiscible in water.

69. Match List I with List II :

LIST I (Compound / Species)		LIST II (Shape / Geometry)	
A.	SF ₄	I.	Tetrahedral
B.	BrF ₃	II.	Pyramidal
C.	BrO ₃ ⁻	III.	See saw
D.	NH ₄ ⁺	IV.	Bent T-shape

Choose the **correct** answer from the options given below :

- (1) A-II, B-III, C-I, D-IV
- (2) A-III, B-IV, C-II, D-I
- (3) A-II, B-IV, C-III, D-I
- (4) A-III, B-II, C-IV, D-I

Ans. (2)

Sol.

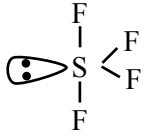
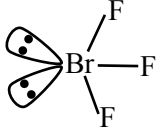
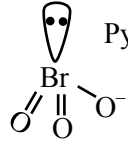
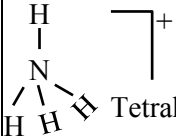
(A)	SF ₄	sp ³ d hybridisation	
(B)	BrF ₃	sp ³ d hybridisation	 Bent T-Shape
(C)	BrO ₃ ⁻	sp ³ hybridisation	 Pyramidal
(D)	NH ₄ ⁺	sp ³ hybridisation	 Tetrahedral

70. In Reimer - Tiemann reaction, phenol is converted into salicylaldehyde through an intermediate. The structure of intermediate is _____.

- (1)
- (2)
- (3)
- (4)

Ans. (4)

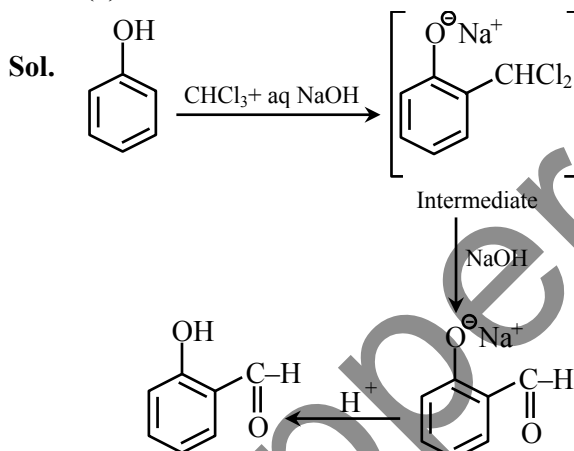

71. Which of the following material is not a semiconductor.

- (1) Germanium
 (2) Graphite
 (3) Silicon
 (4) Copper oxide

Ans. (2)

Sol. Graphite is conductor

72. Consider the following complexes.

- $[\text{CoCl}(\text{NH}_3)_5]^{2+}$, $[\text{Co}(\text{CN})_6]^{3-}$,
 (A) (B)
 $[\text{Co}(\text{NH}_3)_5(\text{H}_2\text{O})]^{3+}$, $[\text{Cu}(\text{H}_2\text{O})_4]^{2+}$
 (C) (D)

The correct order of A, B, C and D in terms of wavenumber of light absorbed is :

- (1) $C < D < A < B$
 (2) $D < A < C < B$
 (3) $A < C < B < D$
 (4) $B < C < A < D$

Ans. (2)

Sol. As ligand field increases, light of more energy is absorbed

Energy \propto wave number

(v)

73. Match List I with List II :

LIST I (Precipitating reagent and conditions)		LIST II (Cation)	
A.	$\text{NH}_4\text{Cl} + \text{NH}_4\text{OH}$	I.	Mn^{2+}
B.	$\text{NH}_4\text{OH} + \text{Na}_2\text{CO}_3$	II.	Pb^{2+}
C.	$\text{NH}_4\text{OH} + \text{NH}_4\text{Cl} + \text{H}_2\text{S gas}$	III.	Al^{3+}
D.	dilute HCl	IV.	Sr^{2+}

Choose the correct answer from the options given below :

- (1) A-IV, B-III, C-II, D-I
 (2) A-IV, B-III, C-I, D-II
 (3) A-III, B-IV, C-I, D-II
 (4) A-III, B-IV, C-II, D-I

Ans. (3)

Sol. Theory based question

74. The electron affinity value are negative for :

- A. $\text{Be} \rightarrow \text{Be}^-$
 B. $\text{N} \rightarrow \text{N}^-$
 C. $\text{O} \rightarrow \text{O}^{2-}$
 D. $\text{Na} \rightarrow \text{Na}^-$
 E. $\text{Al} \rightarrow \text{Al}^-$

Choose the most appropriate answer from the options given below :

- (1) D and E only (2) A, B, D and E only
 (3) A and D only (4) A, B and C only

Allen Ans. (4)

NTA Ans. (1)

- Sol.** (A) $\text{Be} + e^- \rightarrow \text{Be}^-$, E.A = -ive
 (B) $\text{N} + e^- \rightarrow \text{N}^-$ E.A = -ive
 (C) $\text{O} + e^- \rightarrow \text{O}^-$
 $\text{O}^- + e^- \rightarrow \text{O}^{2-}$ E.A = -ive
 (D) $\text{Na} + e^- \rightarrow \text{Na}^-$ E.A = +ive
 (E) $\text{Al} + e^- \rightarrow \text{Al}^-$ E.A = +ive

Ans. A, B and C only

75. The number of element from the following that do not belong to lanthanoids is :

Eu, Cm, Er, Tb, Yb and Lu

- (1) 3 (2) 4
 (3) 1 (4) 5

Ans. (3)

Sol. Cm is Actinide

76. The density of 'x' M solution ('x' molar) of NaOH is 1.12 g mL^{-1} . while in molality, the concentration of the solution is 3 m (3 molal). Then x is (Given : Molar mass of NaOH is 40 g/mol)

- (1) 3.5 (2) 3.0
 (3) 3.8 (4) 2.8

Ans. (2)

Sol.
$$\text{Molality} = \frac{1000 \times M}{1000 \times d - M \times (\text{Mw})_{\text{solute}}}$$

$$3 = \frac{1000 \times x}{1000 \times 1.12 - (x \times 40)}$$

$$x = 3$$

77. Which among the following aldehydes is most reactive towards nucleophilic addition reactions?

- (1) $\text{H} - \overset{\text{O}}{\parallel} \text{C} - \text{H}$ (2) $\text{C}_2\text{H}_5 - \overset{\text{O}}{\parallel} \text{C} - \text{H}$
 (3) $\text{CH}_3 - \overset{\text{O}}{\parallel} \text{C} - \text{H}$ (4) $\text{C}_3\text{H}_7 - \overset{\text{O}}{\parallel} \text{C} - \text{H}$

Ans. (1)

Sol. $\text{H} - \overset{\text{O}}{\parallel} \text{C} - \text{H}$ has low steric hindrance at carbonyl carbon and high partial positive charge at carbonyl carbon.

78. At -20°C and 1 atm pressure, a cylinder is filled with equal number of H_2 , I_2 and HI molecules for the reaction

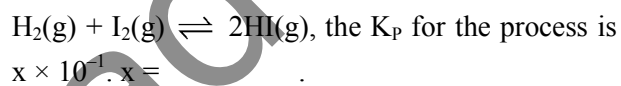

[Given : $R = 0.082 \text{ L atm K}^{-1} \text{ mol}^{-1}$]

- (1) 2 (2) 1
 (3) 10 (4) 0.01

Ans. (3)

Sol. $\Delta n_g = 0$ $K_p = \frac{(n_{\text{HI}})^2}{n_{\text{H}_2} n_{\text{I}_2}} \left(\frac{P_T}{n_T} \right)^{\Delta n_g}$

$n_{\text{HI}} = n_{\text{H}_2} = n_{\text{I}_2}$ so $K_p = 1$
 $1 = x \times 10^{-1}$ $x = 10$

79. Match List I with List II :

LIST I (Compound)		LIST II (Uses)	
A.	Iodoform	I.	Fire extinguisher
B.	Carbon tetrachloride	II.	Insecticide
C.	CFC	III.	Antiseptic
D.	DDT	IV.	Refrigerants

Choose the **correct** answer from the options given below :

- (1) A-I, B-II, C-III, D-IV
 (2) A-III, B-II, C-IV, D-I
 (3) A-III, B-I, C-IV, D-II
 (4) A-II, B-IV, C-I, D-III

Ans. (3)

Sol. Iodoform – Antiseptic
 CCl₄ – Fire extinguisher
 CFC – Refrigerants
 DDT – Insecticide

80. A conductivity cell with two electrodes (dark side) are half filled with infinitely dilute aqueous solution of a weak electrolyte. If volume is doubled by adding more water at constant temperature, the molar conductivity of the cell will -

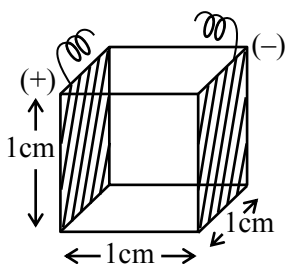

- (1) increase sharply
- (2) remain same or can not be measured accurately
- (3) decrease sharply
- (4) depend upon type of electrolyte

Ans. (2)

Sol. Solution is already infinitely dilute, hence no change in molar conductivity upon addition of water

SECTION-B

81. Consider the dissociation of the weak acid HX as given below

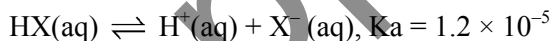

[K_a : dissociation constant]

The osmotic pressure of 0.03 M aqueous solution of HX at 300 K is _____ × 10⁻² bar (nearest integer).

[Given : R = 0.083 L bar Mol⁻¹ K⁻¹]

Ans. (76)

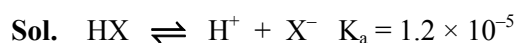

0.03M

0.03 - x x x

$$K_a = 1.2 \times 10^{-5} = \frac{x^2}{0.03 - x}$$

0.03 - x ≈ 0.03 (K_a is very small)

$$\frac{x^2}{0.03} = 1.2 \times 10^{-5}$$

$$x = 6 \times 10^{-4}$$

Final solution : 0.03 - x + x + x

$$= 0.03 + x = 0.03 + 6 \times 10^{-4}$$

$$\Pi = (0.03 + (6 \times 10^{-4})) \times 0.083 \times 300$$

$$= 76.19 \times 10^{-2} \approx 76 \times 10^{-2}$$

82. The difference in the 'spin-only' magnetic moment values of KMnO₄ and the manganese product formed during titration of KMnO₄ against oxalic acid in acidic medium is _____ BM. (nearest integer)

Ans. (6)

Sol. Spin only magnetic moment of Mn in KMnO₄ = 0
 Spin only value of manganese product formed during titration of KMnO₄ against oxalic acid in acidic medium is = 6

Ans. 6

83. Time required for 99.9% completion of a first order reaction is _____ time the time required for completion of 90% reaction. (nearest integer).

Ans. (3)

$$\text{Sol. } K = \frac{1}{t_{99.9\%}} \ln \left(\frac{100}{0.1} \right) = \frac{1}{t_{90\%}} \ln \left(\frac{100}{10} \right)$$

$$t_{99.9\%} = t_{90\%} \frac{\ln(10^3)}{\ln 10}$$

$$t_{99.9\%} = t_{90\%} \times 3$$

84. Number of molecules from the following which can exhibit hydrogen bonding is _____. (nearest integer)

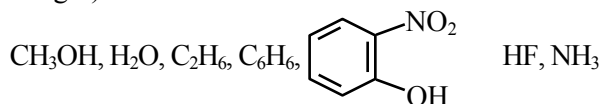

Ans. (5)

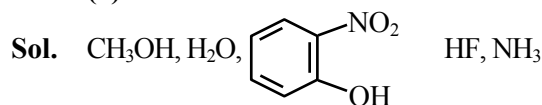

Can show H-bonding.

85. 9.3 g of pure aniline upon diazotisation followed by coupling with phenol gives an orange dye. The mass of orange dye produced (assume 100% yield/ conversion) is _____ g. (nearest integer)

Ans. (20)

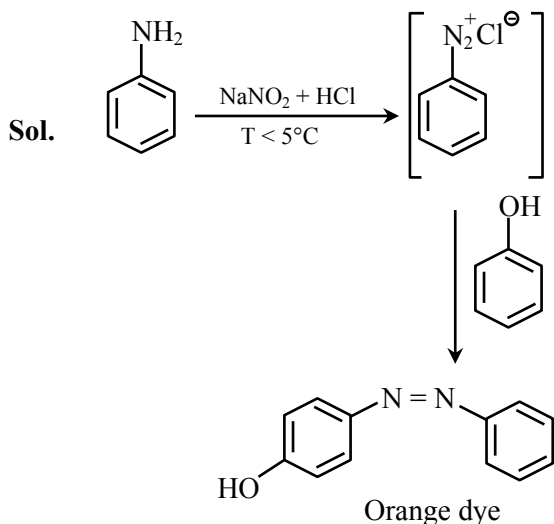

Reaction suggests that 1 mole of aniline give 1 mole of orange dye.

so $(\text{mol})_{\text{aniline}} = (\text{mole})_{\text{orange dye}}$

$$\frac{9.3\text{g}}{93\text{g mol}^{-1}} = \frac{\text{mass of orange dye}}{199\text{g mol}^{-1}}$$

mass of orange dye = 19.9 g \approx 20 g

86. The major product of the following reaction is P.

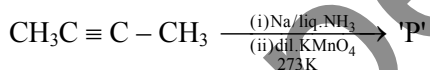

Number of oxygen atoms present in product 'P' is _____ (nearest integer).

Ans. (2)

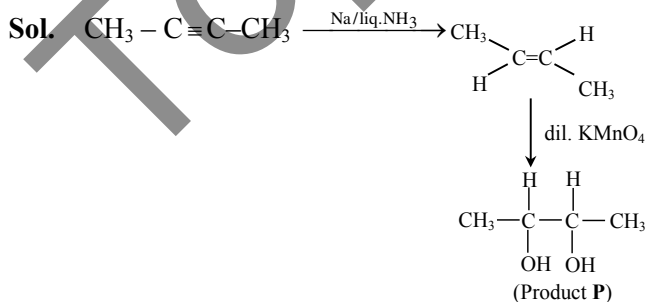

87. Frequency of the de-Broglie wave of electron in Bohr's first orbit of hydrogen atom is _____ $\times 10^{13}$ Hz (nearest integer).

[Given : R_H (Rydberg constant) = 2.18×10^{-18} J.
 h (Plank's constant) = 6.6×10^{-34} J.s.]

Allen Ans. (661)

NTA Ans. (658)

Sol. $\lambda = \frac{h}{mv}$

$$\lambda = \frac{hv}{mv^2}$$

$$\frac{mv^2}{h} = \frac{v}{\lambda} = \nu \text{ (frequency)}$$

Given $\frac{1}{2} mv^2 = 2.18 \times 10^{-18}$ J

$$h = 6.6 \times 10^{-34}$$

$$\nu = \frac{4.36 \times 10^{-18}}{6.6 \times 10^{-34}} = 660.60 \times 10^{13} \text{ Hz}$$

$$\approx 661 \times 10^{13} \text{ Hz}$$

88. The major products from the following reaction sequence are product A and product B.

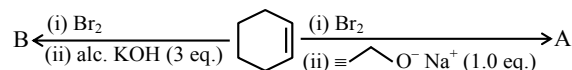

The total sum of π electrons in product A and product B are _____ (nearest integer)

Ans. (8)

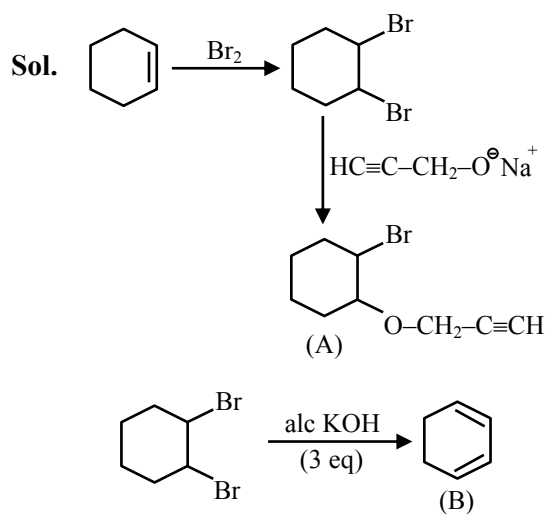

89. Among CrO, Cr₂O₃ and CrO₃, the sum of spin-only magnetic moment values of basic and amphoteric oxides is _____ 10⁻² BM (nearest integer).

(Given atomic number of Cr is 24)

Ans. (877)

Sol. CrO Basic oxide

Cr₂O₃ Amphoteric oxide

In CrO, Cr exist as Cr⁺² and have μ only = 4.90

In Cr₂O₃, Cr exist as Cr⁺³ and have μ only = 3.87

Sum of spin only magnetic moment

$$= 4.90 + 3.87 = 8.77$$

$$\mu_{\text{only}} = 877 \times 10^{-2}$$

Ans. 877

90. An ideal gas, $\bar{C}_v = \frac{5}{2}R$, is expanded adiabatically against a constant pressure of 1 atm until it doubles in volume. If the initial temperature and pressure is 298 K and 5 atm, respectively then the final temperature is _____ K (nearest integer).

[\bar{C}_v is the molar heat capacity at constant volume]

Ans. (274)

Sol. $\Delta U = q + w$ ($q = 0$)

$$nC_v \Delta T = -P_{\text{ext}} (V_2 - V_1)$$

$$V_2 = 2V_1$$

$$\frac{nRT_2}{P_2} = \frac{2nRT_1}{P_1}$$

$$P_1 = 5, T_1 = 298$$

$$P_2 = \frac{5T_2}{2 \times 298}$$

$$n \frac{5}{2} R (T_2 - T_1) = -1 \left(\frac{nRT_2}{P_1} - \frac{nRT_1}{P_1} \right)$$

$$\text{Put } T_1 = 298$$

$$\text{and } P_2 = \frac{5T_2}{2 \times 298}$$

Solve and we get $T_2 = 274.16$ K

$$T_2 \approx 274 \text{ K}$$

FINAL JEE–MAIN EXAMINATION – APRIL, 2024

(Held On Saturday 06th April, 2024)

TIME : 3 : 00 PM to 6 : 00 PM

MATHEMATICS

TEST PAPER WITH SOLUTION

SECTION-A

1. Let ABC be an equilateral triangle. A new triangle is formed by joining the middle points of all sides of the triangle ABC and the same process is repeated infinitely many times. If P is the sum of perimeters and Q is be the sum of areas of all the triangles formed in this process, then:

(1) $P^2 = 36\sqrt{3}Q$ (2) $P^2 = 6\sqrt{3}Q$
 (3) $P = 36\sqrt{3}Q^2$ (4) $P^2 = 72\sqrt{3}Q$

Ans. (1)

Sol.

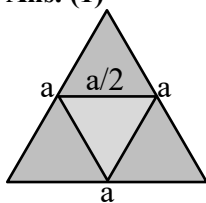

Area of first $\Delta = \frac{\sqrt{3}a^2}{4}$

Area of second $\Delta = \frac{\sqrt{3}a^2}{4} \cdot \frac{a^2}{4} = \frac{\sqrt{3}a^2}{16}$

Area of third $\Delta = \frac{\sqrt{3}a^2}{64}$

sum of area = $\frac{\sqrt{3}a^2}{4} \left(1 + \frac{1}{4} + \frac{1}{16} + \dots \right)$

$Q = \frac{\sqrt{3}a^2}{4} \cdot \frac{1}{\frac{3}{4}} = \frac{a^2}{\sqrt{3}}$

perimeter of 1st $\Delta = 3a$

perimeter of 2nd $\Delta = \frac{3a}{2}$

perimeter of 3rd $\Delta = \frac{3a}{4}$

$P = 3a \left(1 + \frac{1}{2} + \frac{1}{4} + \dots \right)$

$P = 3a \cdot 2 = 6a$

$a = \frac{P}{6}$

$Q = \frac{1}{\sqrt{3}} \cdot \frac{P^2}{36}$

$P^2 = 36\sqrt{3}Q$

2. Let $A = \{1, 2, 3, 4, 5\}$. Let R be a relation on A defined by xRy if and only if $4x \leq 5y$. Let m be the number of elements in R and n be the minimum number of elements from $A \times A$ that are required to be added to R to make it a symmetric relation. Then m + n is equal to:

(1) 24 (2) 23
 (3) 25 (4) 26

Ans. (3)

Sol. Given : $4x \leq 5y$

then

$R = \{(1,1), (1,2), (1,3), (1,4), (1,5), (2,2), (2,3), (2,4), (2,5), (3,3), (3,4), (3,5), (4,4), (4,5), (5,4), (5,5)\}$

i.e. 16 elements.

i.e. m = 16

Now to make R a symmetric relation add

$\{(2,1)(3,2)(4,3)(3,1)(4,2)(5,3)(4,1)(5,2)(5,1)\}$

i.e. n = 9

So m + n = 25

3. If three letters can be posted to any one of the 5 different addresses, then the probability that the three letters are posted to exactly two addresses is:

(1) $\frac{12}{25}$ (2) $\frac{18}{25}$
 (3) $\frac{4}{25}$ (4) $\frac{6}{25}$

Ans. (1)

Sol. Total method = 5^3

favourable = ${}^5C_2 (2^3 - 2) = 60$

probability = $\frac{60}{125} = \frac{12}{25}$

4. Suppose the solution of the differential equation $\frac{dy}{dx} = \frac{(2+\alpha)x - \beta y + 2}{\beta x - 2\alpha y - (\beta\gamma - 4\alpha)}$ represents a circle passing through origin. Then the radius of this circle is :

- (1) $\sqrt{17}$ (2) $\frac{1}{2}$
 (3) $\frac{\sqrt{17}}{2}$ (4) 2

Ans. (3)

Sol.

$$\frac{dy}{dx} = \frac{(2+\alpha)x - \beta y + 2}{\beta x - y(2\alpha + \beta) + 4\alpha}$$

$$\beta x dy - (2\alpha + \beta)y dy + 4\alpha dy = (2+\alpha)x dx - \beta y dx + 2 dx$$

$$\beta(x dy + y dx) - (2\alpha + \beta)y dy + 4\alpha dy = (2+\alpha)x dx + 2 dx$$

$$\beta xy - \frac{(2\alpha + \beta)y^2}{2} + 4\alpha y = \frac{(2+\alpha)x^2}{2}$$

$\Rightarrow \beta = 0$ for this to be circle

$$(2+\alpha)\frac{x^2}{2} + \alpha y^2 + 2x - 4\alpha y = 0$$

coeff. of $\left. \begin{matrix} x^2 \\ y^2 \end{matrix} \right\} 2 + a = 2a$
 $x^2 = y^2$

$$\Rightarrow \boxed{\alpha = 2}$$

i.e. $2x^2 + 2y^2 + 2x - 8y = 0$

$$x^2 + y^2 + x - 4y = 0$$

$$rd = \sqrt{\frac{1}{4} + 4} = \frac{\sqrt{17}}{2}$$

5. If the locus of the point, whose distances from the point (2, 1) and (1, 3) are in the ratio 5 : 4, is $ax^2 + by^2 + cxy + dx + ey + 170 = 0$, then the value of $a^2 + 2b + 3c + 4d + e$ is equal to:

- (1) 5 (2) -27
 (3) 37 (4) 437

Ans. (3)

Sol. let P(x, y)

$$\frac{(x-2)^2 + (y-1)^2}{(x-1)^2 + (y-3)^2} = \frac{25}{16}$$

$$9x^2 + 9y^2 + 14x - 118y + 170 = 0$$

$$a^2 + 2b + 3c + 4d + e$$

$$= 81 + 18 + 0 + 56 - 118$$

$$= 155 - 118$$

$$= 37$$

6. $\lim_{n \rightarrow \infty} \frac{(1^2 - 1)(n-1) + (2^2 - 2)(n-2) + \dots + ((n-1)^2 - (n-1)) \cdot 1}{(1^3 + 2^3 + \dots + n^3) - (1^2 + 2^2 + \dots + n^2)}$

is equal to:

- (1) $\frac{2}{3}$ (2) $\frac{1}{3}$
 (3) $\frac{3}{4}$ (4) $\frac{1}{2}$

Ans. (2)

Sol. $\lim_{n \rightarrow \infty} \frac{\sum_{r=1}^{n-1} (r^2 - r)(n-r)}{\sum_{r=1}^n r^3 - \sum_{r=1}^n r^2}$

$$\lim_{n \rightarrow \infty} \frac{\sum_{r=1}^{n-1} (-r^3 + r^2(n+1) - nr)}{\left(\frac{n(n+1)}{2}\right)^2 - \frac{n(n+1)(2n+1)}{6}}$$

$$\lim_{n \rightarrow \infty} \frac{\left(\frac{(n-1)n}{2}\right)^2 + \frac{(n+1)(n-1)n(2n-1)}{6} - \frac{n^2(n-1)}{2}}{\frac{n(n+1)}{2} \left(\frac{n(n+1)}{2} - \frac{2n+1}{3}\right)}$$

$$\lim_{n \rightarrow \infty} \frac{\frac{n(n-1)}{2} \left(\frac{-n(n-1)}{2} + \frac{(n+1)(2n-1)}{3} - n\right)}{\frac{n(n+1)}{2} \frac{3n^2 + 3n - 4n - 2}{6}}$$

$$\lim_{n \rightarrow \infty} \frac{(n-1)(-3n^2 + 3n + 2(2n^2 + n - 1) - 6)}{(n+1)(3n^2 - n - 2)}$$

$$\lim_{n \rightarrow \infty} \frac{(n-1)(n^2 + 5n - 8)}{(n+1)(3n^2 - n - 2)} = \frac{1}{3}$$

7. Let $0 \leq r \leq n$. If ${}^{n+1}C_{r+1} : {}^nC_r : {}^{n-1}C_{r-1} = 55 : 35 : 21$, then $2n + 5r$ is equal to:

- (1) 60 (2) 62
 (3) 50 (4) 55

Ans. (3)

Ans. $\frac{{}^{n+1}C_r}{{}^nC_r} = \frac{55}{35}$

$$\frac{(n+1)!}{(r+1)!(n-r)!} \cdot \frac{r!(n-r)!}{n!} = \frac{11}{7}$$

$$\frac{(n+1)}{r+1} = \frac{11}{7}$$

Sol. $|(\vec{a} \times \vec{b} \times \vec{c})| = |\vec{a} \times \vec{b}| |\vec{c}| \frac{\sqrt{3}}{2}$

$$|\vec{c} - \vec{a}| = 2\sqrt{2}$$

$$|\vec{c}|^2 + |\vec{a}|^2 - 2\vec{c} \cdot \vec{a} = 8$$

$$|z|^2 + 38 - 12|z| = 8$$

$$|z|^2 - 12|z| + 30 = 0$$

$$|z| = \frac{12 \pm \sqrt{144 - 120}}{2}$$

$$= \frac{12 \pm 2\sqrt{6}}{2}$$

$$|z| = 6 + \sqrt{6}$$

$$\vec{a} \times \vec{b} = \begin{vmatrix} \hat{i} & \hat{j} & \hat{k} \\ 6 & 1 & -1 \\ 1 & 1 & 0 \end{vmatrix}$$

$$\hat{i} - \hat{j} + 5\hat{k}$$

$$|\vec{a} \times \vec{b}| = \sqrt{27}$$

$$|(\vec{a} \times \vec{b}) \times \vec{z}| = \sqrt{27}(6 + \sqrt{6}) \frac{\sqrt{3}}{2}$$

$$\frac{9}{2}(6 + \sqrt{6})$$

12. If all the words with or without meaning made using all the letters of the word "NAGPUR" are arranged as in a dictionary, then the word at 315th position in this arrangement is :

- (1) NRAGUP (2) NRAGPU
 (3) NRAPGU (4) NRAPUG

Ans. (3)

Sol. NAGPUR

$$A \rightarrow 5! = 120$$

$$G \text{ @ } 5! = 120 \quad 240$$

$$NA \text{ @ } 4! = 24 \quad 264$$

$$NG \text{ @ } 4! = 24 \quad 288$$

$$NP \text{ @ } 4! = 24 \quad 312$$

$$NRAGPU = 1 \quad 313$$

$$NRAGUP \quad 314$$

$$NRAPGU \quad 315$$

13. Suppose for a differentiable function h, h(0) = 0, h(1) = 1 and h'(0) = h'(1) = 2. If g(x) = h(e^x) e^{h(x)}}, then g'(0) is equal to:

- (1) 5 (2) 3
 (3) 8 (4) 4

Ans. (4)

Sol. g(x) = h(e^x) · e^{h(x)}}

$$g'(x) = h(e^x) \cdot e^{h(x)} \cdot h'(x) + e^{h(x)} h'(e^x) \cdot e^x$$

$$g'(0) = h(1)e^{h(0)}h'(0) + e^{h(0)}h'(1)$$

$$= 2 + 2 = 4$$

14. Let P (α, β, γ) be the image of the point Q(3, -3, 1) in the line $\frac{x-0}{1} = \frac{y-3}{1} = \frac{z-1}{-1}$ and R be the point

(2, 5, -1). If the area of the triangle PQR is λ and λ² = 14K, then K is equal to:

- (1) 36 (2) 72
 (3) 18 (4) 81

Ans. (4)

Sol.

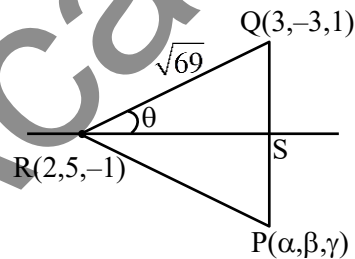

$$RQ = \sqrt{1 + 64 + 4} = \sqrt{69}$$

$$\vec{RQ} = \hat{i} - 8\hat{j} + 2\hat{k}$$

$$\vec{RS} = \hat{i} + \hat{j} - \hat{k}$$

$$\cos \theta = \frac{\vec{RQ} \cdot \vec{RS}}{|\vec{RQ}| |\vec{RS}|} = \frac{|1 - 8 - 2|}{\sqrt{69} \sqrt{3}} = \frac{9}{3\sqrt{23}}$$

$$\cos \theta = \frac{3}{\sqrt{23}} = \frac{RS}{RQ} = \frac{RS}{\sqrt{69}}$$

$$RS = 3\sqrt{3}$$

$$\sin \theta = \frac{\sqrt{14}}{\sqrt{23}} = \frac{QS}{\sqrt{69}}$$

$$QS = \sqrt{42}$$

$$\text{area} = \frac{1}{2} \cdot 2QS \cdot RS = \sqrt{42} \cdot 3\sqrt{3}$$

$$\lambda = 9\sqrt{14}$$

$$\lambda^2 = 81 \cdot 14 = 14k$$

$$k = 81$$

15. If P(6, 1) be the orthocentre of the triangle whose vertices are A(5, -2), B(8, 3) and C(h, k), then the point C lies on the circle.

- (1) $x^2 + y^2 - 65 = 0$ (2) $x^2 + y^2 - 74 = 0$
 (3) $x^2 + y^2 - 61 = 0$ (4) $x^2 + y^2 - 52 = 0$

Ans. (1)

Sol.

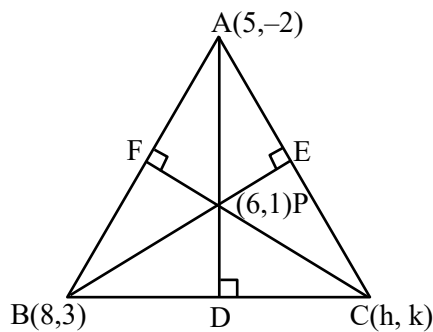

Slope of AD = 3

Slope of BC = $-\frac{1}{3}$

equation of BC = $3y + x - 17 = 0$

slope of BE = 1

Slope of AC = -1

equation of AC is $x + y - 3 = 0$

point C is (-4, 7)

16. Let $f(x) = \frac{1}{7 - \sin 5x}$ be a function defined on R.

Then the range of the function f(x) is equal to:

- (1) $\left[\frac{1}{8}, \frac{1}{5}\right]$ (2) $\left[\frac{1}{7}, \frac{1}{6}\right]$
 (3) $\left[\frac{1}{7}, \frac{1}{5}\right]$ (4) $\left[\frac{1}{8}, \frac{1}{6}\right]$

Ans. (4)

Sol. $\sin 5x \in [-1, 1]$

$-\sin 5x \in [-1, 1]$

$7 - \sin 5x \in [6, 8]$

$\frac{1}{7 - \sin 5x} \in \left[\frac{1}{8}, \frac{1}{6}\right]$

17. Let $\vec{a} = 2\hat{i} + \hat{j} - \hat{k}$, $\vec{b} = ((\vec{a} \times (\hat{i} + \hat{j})) \times \hat{i}) \times \hat{i}$.

Then the square of the projection of \vec{a} on \vec{b} is :

- (1) $\frac{1}{5}$ (2) 2
 (3) $\frac{1}{3}$ (4) $\frac{2}{3}$

Ans. (2)

Sol. $\vec{a} \times (\hat{i} + \hat{j}) = \begin{vmatrix} \hat{i} & \hat{j} & \hat{k} \\ 2 & 1 & -1 \\ 1 & 1 & 0 \end{vmatrix}$

$= \hat{i} - \hat{j} + \hat{k}$

$(\vec{a} \times (\hat{i} + \hat{j})) \times \hat{i} = \hat{k} + \hat{j}$

$((\vec{a} \times (\hat{i} + \hat{j})) \times \hat{i}) \times \hat{i} = \hat{j} - \hat{k}$

projection of \vec{a} on $\hat{b} = \frac{\vec{a} \cdot \vec{b}}{|\vec{b}|}$

$= \frac{1+1}{\sqrt{2}} = \sqrt{2}$

18. If the area of the region

$\left\{ (x, y) : \frac{a}{x^2} \leq y \leq \frac{1}{x}, 1 \leq x \leq 2, 0 < a < 1 \right\}$ is

$(\log_e 2) - \frac{1}{7}$ then the value of $7a - 3$ is equal to:

- (1) 2 (2) 0
 (3) -1 (4) 1

Ans. (3)

Sol.

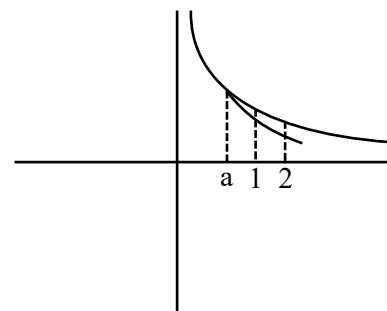

$$\text{area} \int_1^2 \left(\frac{1}{x} - \frac{a}{x^2} \right) dx$$

$$\left[\ln x + \frac{a}{x} \right]_1^2$$

$$\ln 2 + \frac{a}{2} - a = \log_e 2 - \frac{1}{7}$$

$$\frac{-a}{2} = -\frac{1}{7}$$

$$a = \frac{2}{7}$$

$$7a = 2$$

$$7a - 3 = -1$$

19. If $\int \frac{1}{a^2 \sin^2 x + b^2 \cos^2 x} dx = \frac{1}{12} \tan^{-1}(3 \tan x) +$

constant, then the maximum value of

$a \sin x + b \cos x$, is :

(1) $\sqrt{40}$ (2) $\sqrt{39}$

(3) $\sqrt{42}$ (4) $\sqrt{41}$

Ans. (1)

Sol. $\int \frac{\sec^2 x dx}{a^2 \tan^2 x + b^2}$

let $\tan x = t$

$\sec^2 x dx = dt$

$$\int \frac{dt}{a^2 t^2 + b^2}$$

$$\frac{1}{a^2} \int \frac{dt}{t^2 + \left(\frac{b}{a}\right)^2}$$

$$\frac{1}{a^2} \cdot \frac{1}{b} \tan^{-1} \left(\frac{t}{\frac{b}{a}} \right) + c$$

$$\frac{1}{ab} \tan^{-1} \left(\frac{a}{b} \tan x \right) + c$$

on comparing $\frac{a}{b} = 3$

$$ab = 12$$

$$a = 6, b = 2$$

maximum value of

$$6 \sin x + 2 \cos x \text{ is } \sqrt{40}$$

20. If A is a square matrix of order 3 such that

$$\det(A) = 3 \text{ and}$$

$$\det(\text{adj}(-4 \text{adj}(-3 \text{adj}(3 \text{adj}((2A)^{-1})))))) = 2^m 3^n,$$

then $m + 2n$ is equal to:

(1) 3 (2) 2

(3) 4 (4) 6

Ans. (3)

Sol. $|A| = 3$

$$\left| \text{adj}(-4 \text{adj}(-3 \text{adj}(3 \text{adj}((2A)^{-1})))) \right|$$

$$\left| -4 \text{adj}(-3 \text{adj}(3 \text{adj}(2A)^{-1})) \right|^2$$

$$4^6 \left| \text{adj}(-3 \text{adj}(3 \text{adj}(2A)^{-1})) \right|^2$$

$$2^{12} \cdot 3^{12} \left| 3 \text{adj}(2A)^{-1} \right|^8$$

$$2^{12} \cdot 3^{12} \cdot 3^{24} \left| \text{adj}(2A)^{-1} \right|^8$$

$$2^{12} \cdot 3^{36} \left| (2A)^{-1} \right|^{16}$$

$$2^{12} \cdot 3^{36} \frac{1}{|2A|^{16}}$$

$$2^{12} \cdot 3^{36} \frac{1}{2^{48} |A|^{16}}$$

$$2^{12} \cdot 3^{36} \frac{1}{2^{48} \cdot 3^{16}}$$

$$\frac{3^{20}}{2^{36}} = 2^{-36} \cdot 3^{20}$$

$$m = -36 \quad n = 20$$

$$m + 2n = 4$$

SECTION-B

21. Let $[t]$ denote the greatest integer less than or equal to t . Let $f: [0, \infty) \rightarrow \mathbb{R}$ be a function defined by $f(x) = \left[\frac{x}{2} + 3 \right] - [\sqrt{x}]$. Let S be the set of all points in the interval $[0, 8]$ at which f is not continuous. Then $\sum_{a \in S} a$ is equal to _____.

Ans. (17)

Sol. $\left[\frac{x}{2} + 3 \right]$ is discontinuous at $x = 2, 4, 6, 8$

\sqrt{x} is discontinuous at $x = 1, 4$

$F(x)$ is discontinuous at $x = 1, 2, 6, 8$

$$\sum a = 1 + 2 + 6 + 8 = 17$$

22. The length of the latus rectum and directrices of a hyperbola with eccentricity e are 9 and $x = \pm \frac{4}{\sqrt{3}}$,

respectively. Let the line $y - \sqrt{3}x + \sqrt{3} = 0$ touch this hyperbola at (x_0, y_0) . If m is the product of the focal distances of the point (x_0, y_0) , then $4e^2 + m$ is equal to _____.

NTA Ans. (61)

Ans. (Bonus)

Sol. Given $\frac{2b^2}{a} = 9$ and $\frac{a}{e} = \pm \frac{4}{\sqrt{3}}$

equation of tangent $y - \sqrt{3}x + \sqrt{3} = 0$

by equation of tangent

$$\text{Let slope} = S = \sqrt{3}$$

$$\text{Constant} = -\sqrt{3}$$

By condition of tangency

$$\Rightarrow 6 = 6a^2 - 9a$$

$$\Rightarrow a = 2, b^2 = 9$$

Equation of Hyperbola is

$$\frac{x^2}{4} - \frac{y^2}{9} = 1 \text{ and for tangent}$$

Point of contact is $(4, 3\sqrt{3}) = (x_0, y_0)$

$$\text{Now } e = \sqrt{1 + \frac{9}{4}} = \frac{\sqrt{13}}{2}$$

Again product of focal distances

$$m = (x_0 e + a)(x_0 e - a)$$

$$m + 4e^2 = 20e^2 - a^2$$

$$= 20 \times \frac{13}{4} - 4 = 61$$

(There is a printing mistake in the equation of directrix $x = \pm \frac{4}{\sqrt{3}}$.

Corrected equation is $x = \pm \frac{4}{\sqrt{13}}$ for directrix, as

eccentricity must be greater than one, so question must be bonus)

23. If $S(x) = (1+x) + 2(1+x)^2 + 3(1+x)^3 + \dots + 60(1+x)^{60}$, $x \neq 0$, and $(60)^2 S(60) = a(b)^b + b$, where $a, b \in \mathbb{N}$, then $(a+b)$ equal to _____

Ans. (3660)

Sol.

$$S(x) = (1+x) + 2(1+x)^2 + 3(1+x)^3 + \dots + 60(1+x)^{60}$$

$$(1+x)S = (1+x)^2 + \dots + 59(1+x)^{60} + 60(1+x)^{61}$$

$$-xS = \frac{(1+x)(1+x)^{60} - 1}{x} - 60(1+x)^{61}$$

Put $x = 60$

$$-60S = \frac{61((61)^{60} - 1)}{60} - 60(61)^{61}$$

on solving 3660

24. Let $[t]$ denote the largest integer less than or equal to t . If

$$\int_0^3 \left([x^2] + \left[\frac{x^2}{2} \right] \right) dx = a + b\sqrt{2} - \sqrt{3} - \sqrt{5} + c\sqrt{6} - \sqrt{7},$$

where $a, b, c \in \mathbb{Z}$, then $a + b + c$ is equal to _____

Ans. (23)

$$\text{Sol. } \int_0^3 [x^2] dx + \int_0^3 \left[\frac{x^2}{2} \right] dx$$

$$= \int_0^1 0 dx + \int_1^{\sqrt{2}} 1 dx + \int_{\sqrt{2}}^{\sqrt{3}} 2 dx$$

$$\begin{aligned}
 & + \int_{\sqrt{3}}^2 3 dx + \int_2^{\sqrt{5}} 4 dx + \int_{\sqrt{5}}^{\sqrt{6}} 5 dx \\
 & + \int_{\sqrt{6}}^{\sqrt{7}} 6 dx + \int_{\sqrt{7}}^{\sqrt{8}} 7 dx + \int_{\sqrt{8}}^3 8 dx \\
 & + \int_0^{\sqrt{2}} 0 dx + \int_{\sqrt{2}}^2 1 dx \\
 & + \int_2^{\sqrt{6}} 2 dx + \int_{\sqrt{6}}^{\sqrt{8}} 3 dx + \int_{\sqrt{8}}^3 4 dx = 31 - 6\sqrt{2} - \sqrt{3} - \sqrt{5}
 \end{aligned}$$

$$-2\sqrt{6} - \sqrt{7}$$

$$a = 31 \quad b = -6 \quad c = -2$$

$$a + b + c = 31 - 6 - 2 = 23$$

25. From a lot of 12 items containing 3 defectives, a sample of 5 items is drawn at random. Let the random variable X denote the number of defective items in the sample. Let items in the sample be drawn one by one without replacement. If variance of X is $\frac{m}{n}$, where $\gcd(m, n) = 1$, then $n - m$ is equal to _____.

Ans. (71)

Sol. $a = 1 - \frac{{}^3C_5}{{}^{12}C_5}$

$$b = 3 \cdot \frac{{}^9C_4}{{}^{12}C_5}$$

$$c = 3 \cdot \frac{{}^9C_3}{{}^{12}C_5}$$

$$d = 1 \cdot \frac{{}^9C_2}{{}^{12}C_5}$$

$$u = 0.a + 1.b + 2.c + 3.d = 1.25$$

$$\sigma^2 = 0.a + 1.b + 4.c + 9d - u^2$$

$$\sigma^2 = \frac{105}{176}$$

Ans. $176 - 105 = 71$

26. In a triangle ABC, $BC = 7$, $AC = 8$, $AB = \alpha \in \mathbb{N}$ and $\cos A = \frac{2}{3}$. If $49\cos(3C) + 42 = \frac{m}{n}$, where

$\gcd(m, n) = 1$, then $m + n$ is equal to _____

Ans. (39)

26. In a triangle ABC, $BC = 7$, $AC = 8$, $AB = \alpha \in \mathbb{N}$ and $\cos A = \frac{2}{3}$. If $49\cos(3C) + 42 = \frac{m}{n}$, where

$\gcd(m, n) = 1$, then $m + n$ is equal to _____

Ans. (39)

Sol. $\cos A = \frac{b^2 + c^2 - a^2}{2bc}$

$$\frac{2}{3} = \frac{8^2 + c^2 - 7^2}{2 \times 8 \times c}$$

$$C = 9$$

$$\cos C = \frac{7^2 + 8^2 - 9^2}{2 \times 7 \times 8} = \frac{2}{7}$$

$$49 \cos 3C + 42$$

$$49(4 \cos^3 C - 3 \cos C) + 42$$

$$49 \left(4 \left(\frac{2}{7} \right)^3 - 3 \left(\frac{2}{7} \right) \right) + 42$$

$$= \frac{32}{7}$$

$$m + n = 32 + 7 = 39$$

27. If the shortest distance between the lines $\frac{x-\lambda}{3} = \frac{y-2}{-1} = \frac{z-1}{1}$ and $\frac{x+2}{-3} = \frac{y+5}{2} = \frac{z-4}{4}$ is

$\frac{44}{\sqrt{30}}$, then the largest possible value of $|\lambda|$ is equal

to _____.

Ans. (43)

Sol. $\vec{a}_1 = \lambda \hat{i} + 2\hat{j} + \hat{k}$

$$\vec{a}_2 = -2\hat{i} - 5\hat{j} + 4\hat{k}$$

$$\vec{p} = 3\hat{i} - \hat{j} + \hat{k}$$

$$\vec{q} = -3\hat{i} + 2\hat{j} + 4\hat{k}$$

$$(\lambda + 2)\hat{i} + 7\hat{j} - 3\hat{k} = \vec{a}_1 - \vec{a}_2$$

$$\vec{p} \times \vec{q} = -6\hat{i} - 15\hat{j} + 3\hat{k}$$

$$\frac{44}{\sqrt{30}} = \frac{|-6\lambda - 12 - 105 - 9|}{\sqrt{(-6)^2 + (-15)^2 + 3^2}}$$

$$\frac{44}{\sqrt{30}} = \frac{|6\lambda + 126|}{3\sqrt{30}}$$

$$132 = |6\lambda + 126|$$

$$\lambda = 1, \lambda = -43$$

$$|\lambda| = 43$$

28. Let α, β be roots of $x^2 + \sqrt{2}x - 8 = 0$.

$$\text{If } U_n = \alpha^n + \beta^n, \text{ then } \frac{U_{10} + \sqrt{12}U_9}{2U_8}$$

is equal to _____.

Ans. (4)

$$\text{Sol. } \frac{\alpha^{10} + \beta^{10} + \sqrt{2}(\alpha^9 + \beta^9)}{2(\alpha^8 + \beta^8)}$$

$$\frac{\alpha^8(\alpha^2 + \sqrt{2}\alpha) + \beta^8(\beta^2 + \sqrt{2}\beta)}{2(\alpha^8 + \beta^8)}$$

$$\frac{8\alpha^8 + 8\beta^8}{2(\alpha^8 + \beta^8)} = 4$$

29. If the system of equations

$$2x + 7y + \lambda z = 3$$

$$3x + 2y + 5z = 4$$

$$x + \mu y + 32z = -1$$

has infinitely many solutions, then $(\lambda - \mu)$ is equal to _____:

Ans. (38)

$$\text{Sol. } D = D_1 = D_2 = D_3 = 0$$

$$D_3 = \begin{vmatrix} 2 & 7 & 3 \\ 3 & 2 & 4 \\ 1 & \mu & -1 \end{vmatrix} = 0 \Rightarrow \mu = -39$$

$$D = \begin{vmatrix} 2 & 7 & \lambda \\ 3 & 2 & 5 \\ 1 & -39 & 32 \end{vmatrix} = 0 \Rightarrow \lambda = -1$$

$$\lambda - \mu = 38$$

30. If the solution $y(x)$ of the given differential equation $(e^y + 1) \cos x \, dx + e^y \sin x \, dy = 0$ passes through the point $\left(\frac{\pi}{2}, 0\right)$, then the value of $e^{y\left(\frac{\pi}{6}\right)}$ is equal to _____.

Ans. (3)

$$\text{Sol. } (e^y + 1) \cos x \, dx + e^y \sin x \, dy = 0$$

$$\Rightarrow d\left((e^y + 1)\sin x\right) = 0$$

$$(e^y + 1)\sin x = C$$

It passes through $\left(\frac{\pi}{2}, 0\right)$

$$\Rightarrow C = 2$$

$$\text{Now, } x = \frac{\pi}{6}$$

$$\Rightarrow e^y = 3$$

PHYSICS

TEST PAPER WITH SOLUTION

SECTION-A

31. The longest wavelength associated with Paschen series is : (Given $R_H = 1.097 \times 10^7$ SI unit)

- (1) $1.094 \times 10^{-6} \text{m}$ (2) $2.973 \times 10^{-6} \text{m}$
 (3) $3.646 \times 10^{-6} \text{m}$ (4) $1.876 \times 10^{-6} \text{m}$

Ans. (4)

Sol. For longest wavelength in Paschen's series:

$$\frac{1}{\lambda} = R \left[\frac{1}{n_1^2} - \frac{1}{n_2^2} \right]$$

For longest $n_1 = 3$
 $n_2 = 4$

$$\frac{1}{\lambda} = R \left[\frac{1}{(3)^2} - \frac{1}{(4)^2} \right]$$

$$\frac{1}{\lambda} = R \left[\frac{1}{9} - \frac{1}{16} \right]$$

$$\frac{1}{\lambda} = R \left[\frac{16-9}{16 \times 9} \right]$$

$$\Rightarrow \lambda = \frac{16 \times 9}{7R} = \frac{16 \times 9}{7 \times 1.097 \times 10^7}$$

$$\lambda = 1.876 \times 10^{-6} \text{ m}$$

32. A total of 48 J heat is given to one mole of helium kept in a cylinder. The temperature of helium increases by 2°C . The work done by the gas is : (Given, $R = 8.3 \text{ J K}^{-1} \text{ mol}^{-1}$)

- (1) 72.9 J (2) 24.9 J
 (3) 48 J (4) 23.1 J

Ans. (4)

Sol. 1st law of thermodynamics

$$\Delta Q = \Delta U + W$$

$$\Rightarrow +48 = nC_v \Delta T + W$$

$$\Rightarrow 48 = (1) \left(\frac{3R}{2} \right) (2) + W$$

$$\Rightarrow W = 48 - 3 \times R$$

$$\Rightarrow W = 48 - 3 \times (8.3)$$

$$\Rightarrow \boxed{W = 23.1 \text{ Joule}}$$

33. In finding out refractive index of glass slab the following observations were made through travelling microscope 50 vernier scale division = 49 MSD; 20 divisions on main scale in each cm
 For mark on paper

$$\text{MSR} = 8.45 \text{ cm, VC} = 26$$

For mark on paper seen through slab

$$\text{MSR} = 7.12 \text{ cm, VC} = 41$$

For powder particle on the top surface of the glass slab

$$\text{MSR} = 4.05 \text{ cm, VC} = 1$$

(MSR = Main Scale Reading, VC = Vernier Coincidence)

Refractive index of the glass slab is:

- (1) 1.42 (2) 1.52
 (3) 1.24 (4) 1.35

Ans. (1)

Sol. $1 \text{ MSD} = \frac{1 \text{ cm}}{20} = 0.05 \text{ cm}$

$$1 \text{ VSD} = \frac{49}{50} \text{ MSD} = \frac{49}{50} \times 0.05 \text{ cm} = 0.049 \text{ cm}$$

$$\text{LC} = 1 \text{ MSD} - 1 \text{ VSD} = 0.001 \text{ cm}$$

$$\text{For mark on paper, } L_1 = 8.45 \text{ cm} + 26 \times 0.001 \text{ cm} = 84.76 \text{ mm}$$

$$\text{For mark on paper through slab, } L_2 = 7.12 \text{ cm} + 41 \times 0.001 \text{ cm} = 71.61 \text{ mm}$$

$$\text{For powder particle on top surface, } ZE = 4.05 \text{ cm} + 1 \times 0.001 \text{ cm} = 40.51 \text{ mm}$$

$$\therefore \text{ actual } L_1 = 84.76 - 40.51 = 44.25 \text{ mm}$$

$$\text{actual } L_2 = 71.61 - 40.51 = 31.10 \text{ mm}$$

$$L_2 = \frac{L_1}{\mu}$$

$$\Rightarrow \mu = \frac{L_1}{L_2} = \frac{44.25}{31.10} = 1.42$$

34. In the given electromagnetic wave
 $E_y = 600 \sin(\omega t - kx) \text{ Vm}^{-1}$, intensity of the associated light beam is (in W/m^2); (Given $\epsilon_0 = 9 \times 10^{-12} \text{ C}^2 \text{ N}^{-1} \text{ m}^{-2}$)

- (1) 486 (2) 243
 (3) 729 (4) 972

Ans. (1)

Sol. Intensity $= \frac{1}{2} \epsilon_0 E_0^2 c$
 $= \frac{1}{2} \times 9 \times 10^{-12} \times (600)^2 \times 3 \times 10^8$
 $= \frac{9}{2} \times 36 \times 3 = 486 \text{ w/m}^2$

35. Assuming the earth to be a sphere of uniform mass density, a body weighed 300 N on the surface of earth. How much it would weigh at $R/4$ depth under surface of earth ?

- (1) 75 N (2) 375 N
 (3) 300 N (4) 225 N

Ans. (4)

Sol. At surface: $mg = 300 \text{ N}$

$$m = \frac{300}{g_s}$$

At Depth $\frac{R}{4}$: $g_d = g_s \left[1 - \frac{d}{R} \right]$

$$g_d = g_s \left[1 - \frac{R}{4R} \right]$$

$$g_d = \frac{3g_s}{4}$$

weight at depth $= m \times g_d$
 $= m \times \frac{3g_s}{4}$
 $= \frac{3}{4} \times 300$
 $= 225 \text{ N}$

36. The acceptor level of a p-type semiconductor is 6eV. The maximum wavelength of light which can create a hole would be : Given $hc = 1242 \text{ eV nm}$.

- (1) 407 nm (2) 414 nm
 (3) 207 nm (4) 103.5 nm

Ans. (3)

Sol. Energy $= \frac{hc}{\lambda}$;

$$E = \frac{1240}{\lambda(\text{nm})} \text{ eV}$$

$$6 = \frac{1240}{\lambda(\text{nm})}$$

$$\lambda = \frac{1240}{6} = 207 \text{ nm}$$

37. A car of 800 kg is taking turn on a banked road of radius 300 m and angle of banking 30° . If coefficient of static friction is 0.2 then the maximum speed with which car can negotiate the turn safely : ($g = 10 \text{ m/s}^2$, $\sqrt{3} = 1.73$)

- (1) 70.4 m/s (2) 51.4 m/s
 (3) 264 m/s (4) 102.8 m/s

Ans. (2)

Sol. $m = 800 \text{ kg}$

$$r = 300 \text{ m}$$

$$\theta = 30^\circ$$

$$\mu_s = 0.2$$

$$V_{\max} = \sqrt{Rg \left[\frac{\tan \theta + \mu}{1 - \mu \tan \theta} \right]}$$

$$= \sqrt{300 \times g \times \left[\frac{\tan 30^\circ + 0.2}{1 - 0.2 \times \tan 30^\circ} \right]}$$

$$= \sqrt{300 \times 10 \times \left[\frac{0.57 + 0.2}{1 - 0.2 \times 0.57} \right]}$$

$$V_{\max} = 51.4 \text{ m/s}$$

38. Two identical conducting spheres P and S with charge Q on each, repel each other with a force 16N. A third identical uncharged conducting sphere R is successively brought in contact with the two spheres. The new force of repulsion between P and S is :

- (1) 4 N (2) 6 N
 (3) 1 N (4) 12 N

Ans. (2)

Sol.

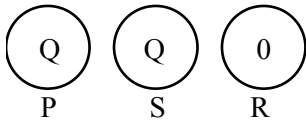

$$F_{PS} \propto Q^2$$

$$F_{PS} = 16 \text{ N}$$

Now If P & R are brought in contact then

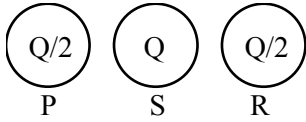

Now If S & R are brought in contact then

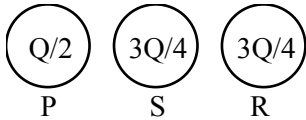

New force between P & S is :

$$F_{PS} \propto \frac{Q}{2} \times \frac{3Q}{4}$$

$$F_{PS} \propto \frac{3Q^2}{8} = \frac{3}{8} \times 16 = 6 \text{ N}$$

39. In a coil, the current changes from -2 A to $+2 \text{ A}$ in 0.2 s and induces an emf of 0.1 V . The self-inductance of the coil is :

- (1) 5 mH (2) 1 mH
 (3) 2.5 mH (4) 4 mH

Ans. (1)

$$\text{Sol. } (\text{Emf})_{\text{induced}} = -L \frac{di}{dt}$$

In magnitude form,

$$|\text{Emf}_{\text{ind}}| = \left| (-)L \frac{di}{dt} \right|$$

$$\Rightarrow 0.1 = \frac{(L)[+2 - (-2)]}{0.2}$$

$$\Rightarrow \boxed{L = \frac{0.1 \times 0.2}{4} = 5 \text{ mH}}$$

40. For the thin convex lens, the radii of curvature are at 15 cm and 30 cm respectively. The focal length the lens is 20 cm . The refractive index of the material is :

- (1) 1.2 (2) 1.4
 (3) 1.5 (4) 1.8

Ans. (3)

$$\begin{aligned} \text{Sol. } \frac{1}{f} &= \left(\frac{\mu_{\text{lens}}}{\mu_{\text{air}}} - 1 \right) \left(\frac{1}{R_1} - \frac{1}{R_2} \right) \\ \Rightarrow \frac{1}{+20} &= \left(\frac{\mu}{1} - 1 \right) \left(\frac{1}{+15} - \frac{1}{(-30)} \right) \\ \Rightarrow \frac{1}{20} &= (\mu - 1) \left(\frac{3}{30} \right) \\ \Rightarrow \mu - 1 &= \frac{1}{2} \\ \Rightarrow \mu &= 1 + \frac{1}{2} = \frac{3}{2} = 1.5 \end{aligned}$$

41. Energy of 10 non rigid diatomic molecules at temperature T is :

- (1) $\frac{7}{2} RT$ (2) $70 K_B T$
 (3) $35 RT$ (4) $35 K_B T$

Ans. (4)

Sol. Degree of freedom (f) = $5 + 2(3N - 5)$
 $f = 5 + 2(3 \times 2 - 5) = 7$

$$\text{energy of one molecule} = \frac{f}{2} K_B T$$

energy of 10 molecules

$$= 10 \left(\frac{f}{2} K_B T \right) = 10 \left(\frac{7}{2} K_B T \right) = 35 K_B T$$

42. A body of weight 200 N is suspended from a tree branch through a chain of mass 10 kg . The branch pulls the chain by a force equal to (if $g = 10 \text{ m/s}^2$):

- (1) 150 N (2) 300 N
 (3) 200 N (4) 100 N

Ans. (2)

Sol.

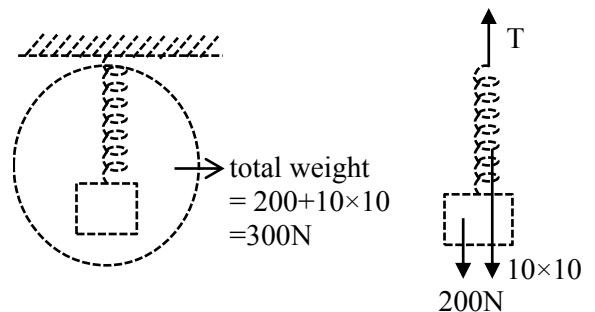

Chain block system is in equilibrium so

$$T = 200 + 100 = 300 \text{ N.}$$

43. When UV light of wavelength 300 nm is incident on the metal surface having work function 2.13 eV, electron emission takes place. The stopping potential is : (Given $hc = 1240 \text{ eV nm}$)

- (1) 4 V (2) 4.1 V (3) 2 V (4) 1.5 V

Ans. (3)

Sol. $\frac{hc}{\lambda} - \phi = e \cdot V_s$

$\Rightarrow \frac{1240}{300} \text{ eV} - 2.13 \text{ eV} = eV_s$

$\Rightarrow 4.13 \text{ eV} - 2.13 \text{ eV} = eV_s$

\Rightarrow So, $V_s = 2 \text{ volt}$

44. The number of electrons flowing per second in the filament of a 110 W bulb operating at 220 V is : (Given $e = 1.6 \times 10^{-19} \text{ C}$)

- (1) 31.25×10^{17} (2) 6.25×10^{18}
 (3) 6.25×10^{17} (4) 1.25×10^{19}

Ans. (1)

Sol. Power (P) = V.I

$\Rightarrow 110 = (220) (I)$

$\Rightarrow I = 0.5 \text{ A}$

Now, $I = \frac{n \cdot e}{t}$

$\Rightarrow 0.5 = \left(\frac{n}{t}\right) (1.6 \times 10^{-19})$

$\Rightarrow \frac{n}{t} = \frac{0.5}{1.6 \times 10^{-19}}$

$\Rightarrow \frac{n}{t} = 31.25 \times 10^{17}$

45. When kinetic energy of a body becomes 36 times of its original value, the percentage increase in the momentum of the body will be :

- (1) 500% (2) 600%
 (3) 6% (4) 60%

Ans. (1)

Sol. Kinetic energy (K) = $\frac{P^2}{2m}$

$\Rightarrow P = \sqrt{2mK}$

If $K_f = 36 K_i$

So, $P_f = 6 P_i$

% increase in momentum = $\frac{P_f - P_i}{P_i} \times 100\%$

= $\frac{6P_i - P_i}{P_i} \times 100\%$

= 500%

46. Pressure inside a soap bubble is greater than the pressure outside by an amount :

(given : R = Radius of bubble, S = Surface tension of bubble)

- (1) $\frac{4S}{R}$ (2) $\frac{4R}{S}$
 (3) $\frac{S}{R}$ (4) $\frac{2S}{R}$

Ans. (1)

Sol. There are two liquid-air surfaces in bubble so

$\Delta P = 2 \left(\frac{2S}{R}\right) = \frac{4S}{R}$

47. Match List-I with List-II

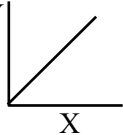
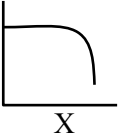
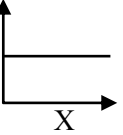
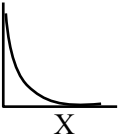
	List-I (Y vs X)	List-II (Shape of Graph)
(A)	Y = magnetic susceptibility X = magnetising field	(I) 
(B)	Y = magnetic field X = distance from centre of a current carrying wire for $x < a$ (where a = radius of wire)	(II) 
(C)	Y = magnetic field X = distance from centre of a current carrying wire for $x > a$ (where a = radius of wire)	(III) 
(D)	Y = magnetic field inside solenoid X = distance from center	(IV) 

Choose the correct answer from the options given below :

- (1) (A)-(III), (B)-(I), (C)-(IV), (D)-(II)
 (2) (A)-(I), (B)-(III), (C)-(II), (D)-(IV)
 (3) (A)-(IV), (B)-(I), (C)-(III), (D)-(II)
 (4) (A)-(III), (B)-(IV), (C)-(I), (D)-(II)

Ans. (4)

Sol. (A) Graph between Magnetic susceptibility and magnetising field is :

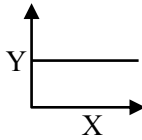

(B) magnetic field due to a current carrying wire for $x < a$:

$$B = \frac{\mu_0 i r}{2\pi a^2}$$

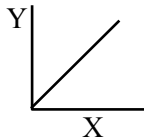

(C) magnetic field due to a current carrying wire for $x > a$:

$$B = \frac{\mu_0 i}{2\pi a}$$

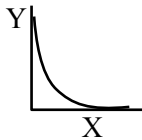

(D) magnetic field inside solenoid varies as:

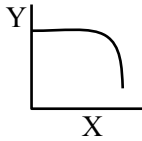

48. In a vernier calliper, when both jaws touch each other, zero of the vernier scale shifts towards left and its 4th division coincides exactly with a certain division on main scale. If 50 vernier scale divisions equal to 49 main scale divisions and zero error in the instrument is 0.04 mm then how many main scale divisions are there in 1 cm ?

- (1) 40 (2) 5
(3) 20 (4) 10

NTA Ans. (3)

Sol. 4th division coincides with 3rd division then

$$0.004 \text{ cm} = 4\text{VSD} - 3\text{MSD}$$

$$49\text{MSD} = 50 \text{VSD}$$

$$1\text{MSD} = \frac{1}{N} \text{ cm}$$

$$0.004 = 4 \left\{ \frac{49}{50} \text{MSD} \right\} - 3\text{MSD}$$

$$0.004 = \left(\frac{196}{50} - 3 \right) \left(\frac{1}{N} \right)$$

$$N = \frac{46}{50} \times \frac{1000}{4} = \frac{46 \times 1000}{200} = 230$$

49. Given below are two statements :

Statement (I) : Dimensions of specific heat is $[L^2 T^{-2} K^{-1}]$

Statement (II) : Dimensions of gas constant is $[M L^2 T^{-1} K^{-1}]$

- (1) Statement (I) is incorrect but statement (II) is correct
(2) Both statement (I) and statement (II) are incorrect
(3) Statement (I) is correct but statement (II) is incorrect
(4) Both statement (I) and statement (II) are correct

Ans. (3)

Sol. $\Delta Q = mS\Delta T$

$$s = \frac{\Delta Q}{m\Delta T}$$

$$[s] = \left[\frac{ML^2 T^{-2}}{MK} \right]$$

$$[s] = [L^2 T^{-2} K^{-1}]$$

Statement-(I) is correct

$$PV = nRT \Rightarrow R = \frac{PV}{nT}$$

$$[R] = \frac{[ML^{-1}T^{-2}][L^3]}{[mol][K]}$$

$$[R] = [ML^2 T^{-2} \text{ mol}^{-1} K^{-1}]$$

Statement-II is incorrect

50. A body projected vertically upwards with a certain speed from the top of a tower reaches the ground in t_1 . If it is projected vertically downwards from the same point with the same speed, it reaches the ground in t_2 . Time required to reach the ground, if it is dropped from the top of the tower, is :

- (1) $\sqrt{t_1 t_2}$ (2) $\sqrt{t_1 - t_2}$
(3) $\sqrt{\frac{t_1}{t_2}}$ (4) $\sqrt{t_1 + t_2}$

Ans. (1)

Sol. $t_1 = \frac{u + \sqrt{u^2 + 2gh}}{g}$
 $t_2 = \frac{-u + \sqrt{u^2 + 2gh}}{g}$
 $t = \frac{\sqrt{2gh}}{g}$
 $t_1 t_2 = \frac{(u^2 + 2gh) - u^2}{g^2} = \frac{2gh}{g^2} = t^2$
 $\Rightarrow t = \sqrt{t_1 t_2}$

SECTION-B

51. In Franck-Hertz experiment, the first dip in the current-voltage graph for hydrogen is observed at 10.2 V. The wavelength of light emitted by hydrogen atom when excited to the first excitation level is _____ nm.
 (Given $hc = 1245 \text{ eV nm}$, $e = 1.6 \times 10^{-19} \text{ C}$).

Ans. (122)

Sol. $10.2 \text{ eV} = \frac{hc}{\lambda}$
 $\lambda = \frac{1245 \text{ eV} \cdot \text{nm}}{10.2 \text{ eV}} = 122.06 \text{ nm}$

52. For a given series LCR circuit it is found that maximum current is drawn when value of variable capacitance is 2.5 nF. If resistance of 200Ω and 100 mH inductor is being used in the given circuit. The frequency of ac source is _____ $\times 10^3$ Hz.
 (given $\pi^2 = 10$)

Ans. (10)

Sol. for maximum current, circuit must be in resonance.

$f_0 = \frac{1}{2\pi\sqrt{L \times C}}$
 $f_0 = \frac{1}{2\pi\sqrt{100 \times 10^{-3} \times 2.5 \times 10^{-9}}}$
 $= \frac{1}{2\pi\sqrt{25 \times 10^{-11}}}$
 $= \frac{1}{2\pi \times 5} \times 10^5 \times \sqrt{10} \text{ Hz}$
 $= \frac{100}{10} \times 10^3 \text{ Hz}$
 $f_0 = 10 \times 10^3 \text{ Hz}$

53. A particle moves in a straight line so that its displacement x at any time t is given by $x^2 = 1 + t^2$. Its acceleration at any time t is x^{-n} where $n =$ _____.

Ans. (3)

Sol. $x^2 = 1 + t^2$
 $2x \frac{dx}{dt} = 2t$
 $xv = t$
 $x \frac{dv}{dt} + v \frac{dx}{dt} = 1$
 $x \cdot a + v^2 = 1$
 $a = \frac{1 - v^2}{x} = \frac{1 - t^2 / x^2}{x}$
 $a = \frac{1}{x^3} = x^{-3}$

54. Three balls of masses 2kg, 4kg and 6kg respectively are arranged at centre of the edges of an equilateral triangle of side 2 m. The moment of inertia of the system about an axis through the centroid and perpendicular to the plane of triangle, will be _____ kg m^2 .

Ans. (4)

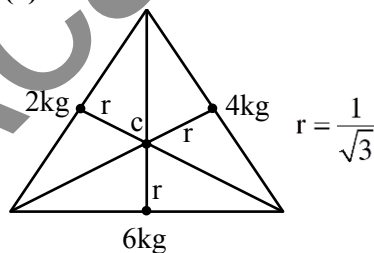

Moment of inertia about C and perpendicular to the plane is :

$I = r^2 [2 + 4 + 6]$
 $= \frac{1}{3} \times 12$

$I = 4 \text{ kg-m}^2$

55. A coil having 100 turns, area of $5 \times 10^{-3} \text{ m}^2$, carrying current of 1 mA is placed in uniform magnetic field of 0.20 T such a way that plane of coil is perpendicular to the magnetic field. The work done in turning the coil through 90° is _____ μJ .

Ans. (100)

Sol. $W = \Delta U = U_f - U_i$
 $W = (-\vec{\mu} \cdot \vec{B})_f - (-\vec{\mu} \cdot \vec{B})_i$
 $= 0 + (\vec{\mu} \cdot \vec{B})_i$
 $= (100 \times 5 \times 10^{-3} \times 1 \times 10^{-3}) \times 0.2 \text{ J}$
 $= 1 \times 10^{-4} \text{ J} = 100 \mu\text{J}$

56. In the given figure an ammeter A consists of a 240Ω coil connected in parallel to a 10Ω shunt. The reading of the ammeter is _____ mA.

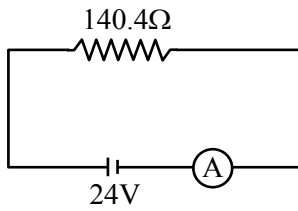

Ans. (160)

Sol.

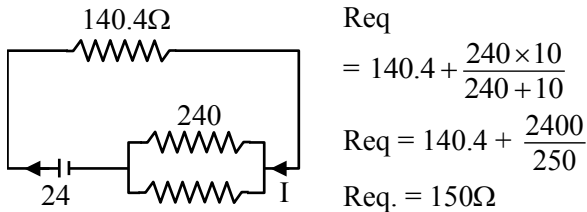

$$\begin{aligned} \therefore \text{Current in ammeter} &= \frac{24}{150} \\ &= 160 \text{ mA} \end{aligned}$$

57. A wire of cross sectional area A , modulus of elasticity $2 \times 10^{11} \text{ Nm}^{-2}$ and length 2 m is stretched between two vertical rigid supports. When a mass of 2 kg is suspended at the middle it sags lower from its original position making angle $\theta = \frac{1}{100}$ radian on the points of support. The value of A is _____ $\times 10^{-4} \text{ m}^2$ (consider $x \ll L$). (given : $g = 10 \text{ m/s}^2$)

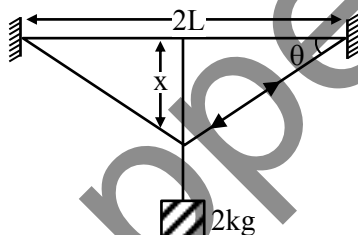

Ans. (1)

Sol.

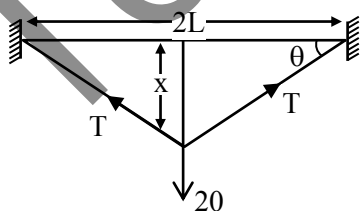

In vertical direction
 $2T \sin\theta = 20$

using small angle approximation $\sin\theta = \theta$

$$\theta = \frac{1}{100}$$

$$\therefore T = \frac{10}{\theta}$$

$$T = 1000 \text{ N}$$

$$\text{Change in length } \Delta L = 2\sqrt{x^2 + L^2} - 2L$$

$$= 2L \left[1 + \frac{x^2}{2L^2} - 1 \right]$$

$$\Delta L = \frac{x^2}{L}$$

$$\therefore \text{Modulus of elasticity} = \frac{\text{stress}}{\text{strain}}$$

$$2 \times 10^{11} = \frac{10^3}{A \times \frac{x^2}{L}} \times 2L$$

$$\therefore A = 1 \times 10^{-4} \text{ m}^2$$

58. Two coherent monochromatic light beams of intensities I and $4I$ are superimposed. The difference between maximum and minimum possible intensities in the resulting beam is xI . The value of x is _____.

Ans. (8)

$$\text{Sol. } I_{\max} = (\sqrt{I} + \sqrt{4I})^2 = 9I$$

$$I_{\min} = (\sqrt{4I} - \sqrt{I})^2 = I$$

$$\therefore I_{\max} - I_{\min} = 8I$$

59. Two open organ pipes of length 60 cm and 90 cm resonate at 6^{th} and 5^{th} harmonics respectively. The difference of frequencies for the given modes is _____ Hz.

(Velocity of sound in air = 333 m/s)

Ans. (740)

Sol. The difference in frequency in open organ pipe =

$$f = \frac{nv}{2L}$$

$$\Delta f = \frac{6v}{2 \times 0.6} - \frac{5v}{2 \times 0.9}$$

$$v = 333 \text{ m/s}$$

$$\Delta f = 740 \text{ Hz}$$

60. A capacitor of $10 \mu\text{F}$ capacitance whose plates are separated by 10 mm through air and each plate has area 4 cm^2 is now filled equally with two dielectric media of $K_1 = 2$, $K_2 = 3$ respectively as shown in figure. If new force between the plates is 8 N . The supply voltage is _____ V.

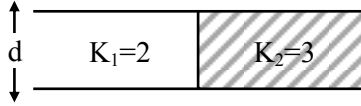

NTA Ans. (80)

Sol.

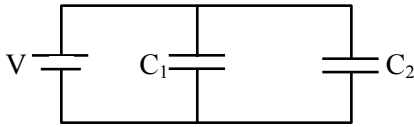

$$C_{\text{eq}} = C_1 + C_2$$

$$C_1 = \frac{2\epsilon_0 A}{2 \times d} = 10 \mu\text{F}$$

$$C_2 = \frac{3\epsilon_0 A}{2d} = 15 \mu\text{F}$$

$$C_{\text{eq}} = 25 \mu\text{F}$$

Now the charge on $C_1 = 10V \mu\text{C}$
 $C_2 = 1.5 V \mu\text{C}$.

Now force between the plates $\left[F = \frac{Q^2}{2A\epsilon_0} \right]$

$$\frac{100V^2 \times 10^{-12}}{2 \times 2 \times 10^{-4} \epsilon_0} + \frac{225V^2 \times 10^{-12}}{2 \times 2 \times 10^{-4} \times \epsilon_0} = 8$$

$$325 V^2 = 8 \times 4 \times 10^{-4} \times 8.85$$

$$V^2 = \frac{32 \times 8.85 \times 10^{-4}}{325}$$

$$\therefore V = \sqrt{\frac{283.2 \times 10^{-4}}{325}}$$

$$V = 0.93 \times 10^{-2}$$

CHEMISTRY

SECTION-A

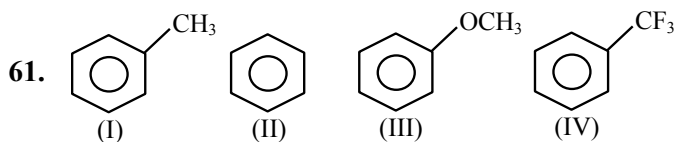

The **correct** arrangement for decreasing order of electrophilic substitution for above compounds

- (1) (IV) > (I) > (II) > (III)
 (2) (III) > (I) > (II) > (IV)
 (3) (II) > (IV) > (III) > (I)
 (4) (III) > (IV) > (II) > (I)

Ans. (2)

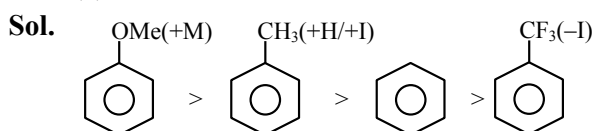

62. Molality (m) of 3 M aqueous solution of NaCl is:
 (Given : Density of solution = 1.25 g mL⁻¹, Molar mass in g mol⁻¹ : Na-23, Cl-35.5)

- (1) 2.90 m (2) 2.79 m
 (3) 1.90 m (4) 3.85 m

Ans. (2)

Sol. 3 moles are present in 1 litre solution

$$\text{molality} = \frac{3 \times 1000}{1.25 \times 1000 - [3 \times 58.5]} = 2.79 \text{ m}$$

63. The incorrect statements regarding enzymes are:

- (A) Enzymes are biocatalysts.
 (B) Enzymes are non-specific and can catalyse different kinds of reactions.
 (C) Most Enzymes are globular proteins.
 (D) Enzyme - oxidase catalyses the hydrolysis of maltose into glucose.

Choose the correct answer from the option given below:

- (1) (B) and (C) (2) (B), (C) and (D)
 (3) (B) and (D) (4) (A), (B) and (C)

Ans. (3)

TEST PAPER WITH SOLUTION

Sol. Direct NCERT Based

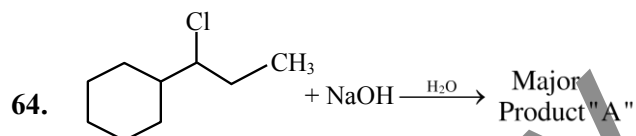

Consider the above chemical reaction. Product "A" is:

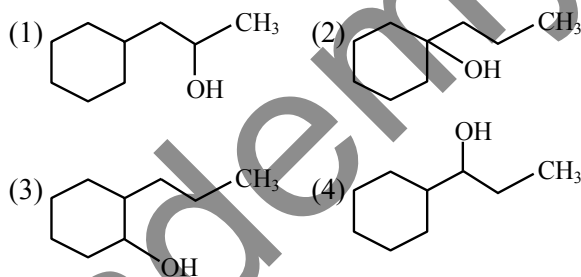

Ans. (2)

Sol.

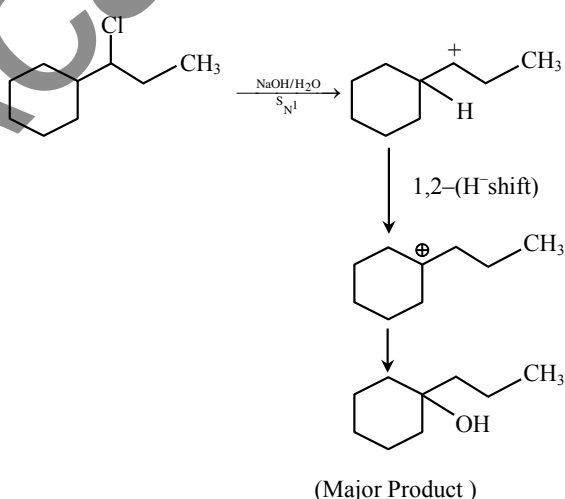

65. During the detection of acidic radical present in a salt, a student gets a pale yellow precipitate soluble with difficulty in NH₄OH solution when sodium carbonate extract was first acidified with dil. HNO₃ and then AgNO₃ solution was added. This indicates presence of:

- (1) Br⁻ (2) CO₃²⁻
 (3) I⁻ (4) Cl⁻

Ans. (1)

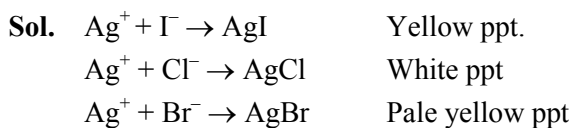

66. How can an electrochemical cell be converted into an electrolytic cell ?

- (1) Applying an external opposite potential greater than E_{cell}^0
- (2) Reversing the flow of ions in salt bridge.
- (3) Applying an external opposite potential lower than E_{cell}^0 .
- (4) Exchanging the electrodes at anode and cathode.

Ans. (1)

Sol. Applied external potential should be greater than E_{cell}^0 in opposite direction.

67. Arrange the following elements in the increasing order of number of unpaired electrons in it.

- (A) Sc (B) Cr
 (C) V (D) Ti
 (E) Mn

Choose the correct answer from the options given below:

- (1) (C) < (E) < (B) < (A) < (D)
- (2) (B) < (C) < (D) < (E) < (A)
- (3) (A) < (D) < (C) < (B) < (E)
- (4) (A) < (D) < (C) < (E) < (B)

Ans. (4)

Sol. Unpaired electron

Sc [Ar] $4s^2 3d^1$	1
Cr [Ar] $4s^1 3d^5$	6
V [Ar] $4s^2 3d^3$	3
Ti : [Ar] $4s^2 3d^2$	2
Mn : [Ar] $4s^2 3d^5$	5

68. Match List-I with List-II.

List-I	List-II
Alkali Metal	Emission Wavelength in nm

- | | |
|--------|-------------|
| (A) Li | (I) 589.2 |
| (B) Na | (II) 455.5 |
| (C) Rb | (III) 670.8 |
| (D) Cs | (IV) 780.0 |

Choose the correct answer from the options given below:

- (1) (A)-(I), (B)-(IV), (C)-(III), (D)-(II)
- (2) (A)-(III), (B)-(I), (C)-(IV), (D)-(II)
- (3) (A)-(IV), (B)-(II), (C)-(I), (D)-(III)
- (4) (A)-(II), (B)-(IV), (C)-(III), (D)-(I)

Ans. (2)

Sol. Fact Based

69. The major products formed:

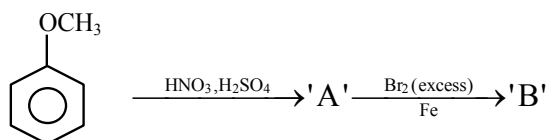

A and B respectively are:

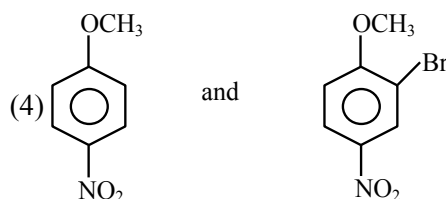
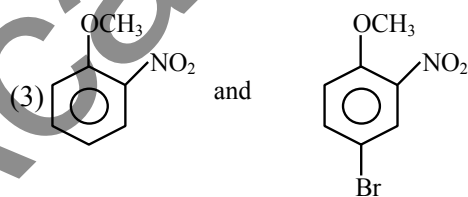
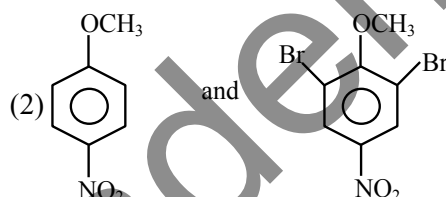
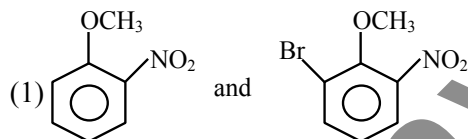

Ans. (2)

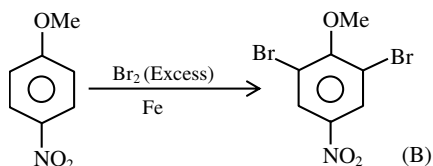
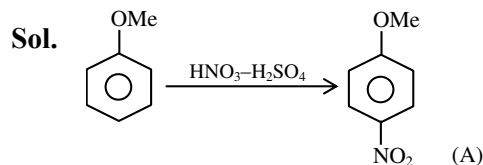

70. The incorrect statement regarding the geometrical isomers of 2-butene is:

- (1) cis-2-butene and trans-2-butene are not interconvertible at room temperature.
- (2) cis-2-butene has less dipole moment than trans-2-butene.
- (3) trans-2-butene is more stable than cis-2-butene.
- (4) cis-2-butene and trans-2-butene are stereoisomers.

Ans. (2)

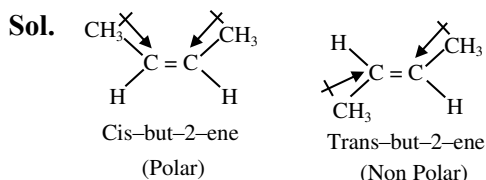

Cis-but-2-ene has higher Dipole moment than trans-but-2-ene.

71. Given below are two statements:

Statement I: PF_5 and BrF_5 both exhibit sp^3d hybridisation.

Statement II: Both SF_6 and $[\text{Co}(\text{NH}_3)_6]^{3+}$ exhibit sp^3d^2 hybridisation.

In the light of the above statements, choose the correct answer from the options given below:

- (1) **Statement I** is true but **Statement II** is false
- (2) Both **Statement I** and **Statement II** are true
- (3) Both **Statement I** and **Statement II** are false
- (4) **Statement I** is false but **Statement II** is true

Ans. (3)



Both Statement (1) and (2) are false.

72. The number of ions from the following that are expected to behave as oxidising agent is:

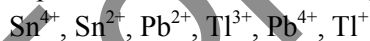

- (1) 3
- (2) 4
- (3) 1
- (4) 2

Ans. (4)

Sol. Due to inert pair effect; Tl^{+3} and Pb^{+4} can behave as oxidising agents.

73. Identify the product (A) in the following reaction.

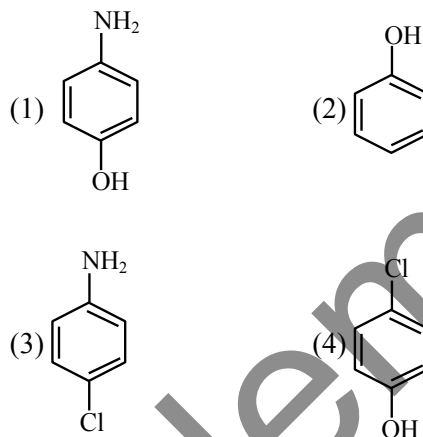
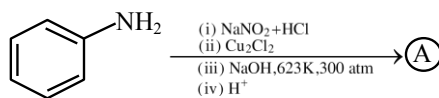

Ans. (2)

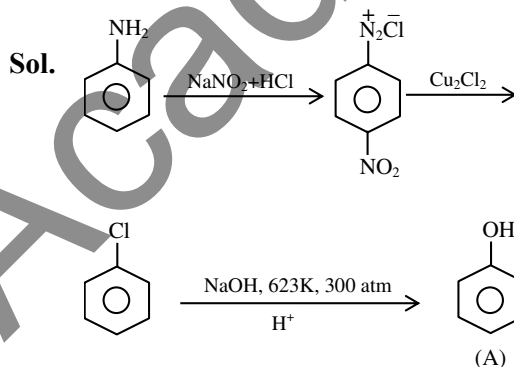

74. The correct statements among the following, for a "chromatography" purification method is:

- (1) Organic compounds run faster than solvent in the thin layer chromatographic plate.
- (2) Non-polar compounds are retained at top and polar compounds come down in column chromatography.
- (3) R_f of a polar compound is smaller than that of a non-polar compound.
- (4) R_f is an integral value.

Ans. (3)

Sol. Non polar compounds are having higher value of R_f than polar compound.

75. Evaluate the following statements related to group 14 elements for their correctness.
- (A) Covalent radius decreases down the group from C to Pb in a regular manner.
- (B) Electronegativity decreases from C to Pb down the group gradually.
- (C) Maximum covalence of C is 4 whereas other elements can expand their covalence due to presence of d orbitals.
- (D) Heavier elements do not form $p\pi-p\pi$ bonds.
- (E) Carbon can exhibit negative oxidation states.
- Choose the **correct** answer from the options given below:

- (1) (C), (D) and (E) Only (2) (A) and (B) Only
 (3) (A), (B) and (C) Only (4) (C) and (D) Only

Ans. (1)

- Sol.** (A) Down the group, radius increases
 (B) EN does not decrease gradually from C to Pb.
 (C) Correct.
 (D) Correct.
 (E) Range of oxidation state of carbon ; -4 to +4

76. Match List-I with the List-II

List-I Reaction	List-II Type of redox reaction
(A) $N_{2(g)} + O_{2(g)} \rightarrow 2NO_{(g)}$	(I) Decomposition
(B) $2Pb(NO_3)_{2(s)} \rightarrow 2PbO_{(s)} + 4NO_{2(g)} + O_{2(g)}$	(II) Displacement
(C) $2Na_{(s)} + 2H_2O_{(l)} \rightarrow 2NaOH_{(aq)} + H_{2(g)}$	(III) Disproportionation
(D) $2NO_{2(g)} + 2OH_{(aq)}^- \rightarrow NO_{2(aq)}^- + NO_{3(aq)}^- + H_2O_{(l)}$	(IV) Combination

Choose the **correct** answer from the options given below:

- (1) (A)-(I), (B)-(II), (C)-(III), (D)-(IV)
 (2) (A)-(III), (B)-(II), (C)-(I), (D)-(IV)
 (3) (A)-(II), (B)-(III), (C)-(IV), (D)-(I)
 (4) (A)-(IV), (B)-(I), (C)-(II), (D)-(III)

Ans. (4)

- Sol.** A \rightarrow (IV)
 B \rightarrow (I)
 C \rightarrow (II)
 D \rightarrow (III)

77. Consider the given reaction, identify the major product P.

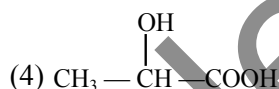
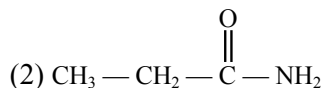
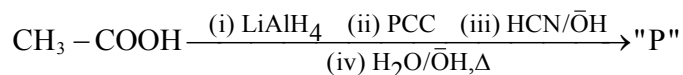

Ans. (4)

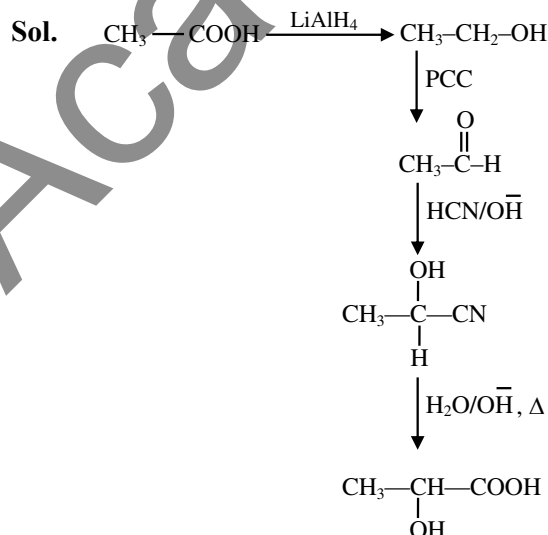

78. The correct IUPAC name of $[PtBr_2(PMe_3)_2]$ is:

- (1) bis(trimethylphosphine)dibromoplatinum(II)
 (2) bis[bromo(trimethylphosphine)]platinum(II)
 (3) dibromobis(trimethylphosphine)platinum(II)
 (4) dibromodi(trimethylphosphine)platinum(II)

Ans. (3)

Sol. Dibromo bis(trimethylphosphine) platinum (II)

79. Match List-I with List-II

List-I Tetrahedral Complex	List-II Electronic configuration
(A) $TiCl_4$	(I) e^2, t_2^0
(B) $[FeO_4]^{2-}$	(II) e^4, t_2^3
(C) $[FeCl_4]^-$	(III) e^0, t_2^0
(D) $[CoCl_4]^{2-}$	(IV) e^2, t_2^3

Choose the **correct** answer from the option given below:

- (1) (A)-(I), (B)-(III), (C)-(IV), (D)-(II)
 (2) (A)-(IV), (B)-(III), (C)-(I), (D)-(II)
 (3) (A)-(III), (B)-(IV), (C)-(II), (D)-(I)
 (4) (A)-(III), (B)-(I), (C)-(IV), (D)-(II)

Ans. (4)

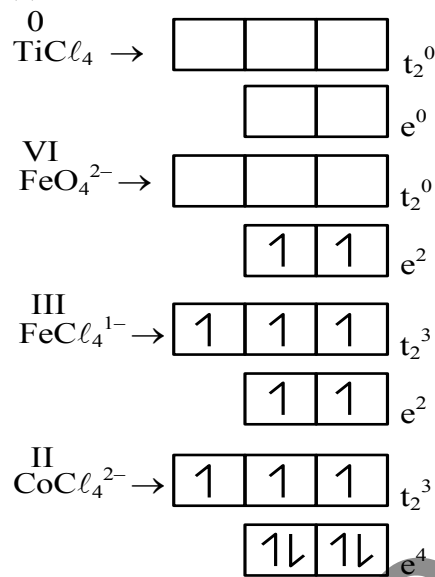

Sol.

80. The ratio $\frac{K_P}{K_C}$ for the reaction:

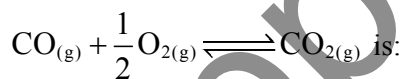

- (1) $(RT)^{1/2}$ (2) RT
 (3) 1 (4) $\frac{1}{\sqrt{RT}}$

Ans. (4)

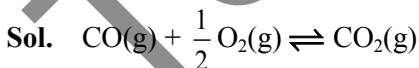

$$\Delta n_g = 1 - \left(1 + \frac{1}{2}\right) = -\frac{1}{2}$$

$$\frac{K_P}{K_C} = (RT)^{\Delta n_g} = \frac{1}{\sqrt{RT}}$$

SECTION-B

81. An amine (X) is prepared by ammonolysis of benzyl chloride. On adding p-toluenesulphonyl chloride to it the solution remains clear. Molar mass of the amine (X) formed is _____ $g\ mol^{-1}$.
 (Given molar mass in $g\ mol^{-1}$ C : 12, H : 1, O : 16, N : 14)

Ans. (287)

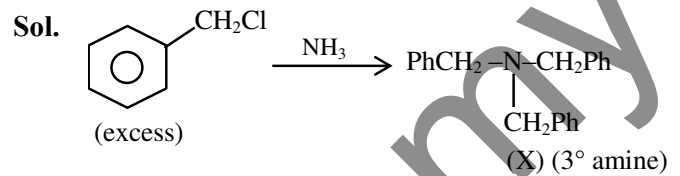

Molar Mass of (X) is $287\ g\ mol^{-1}$

82. Consider the following reactions

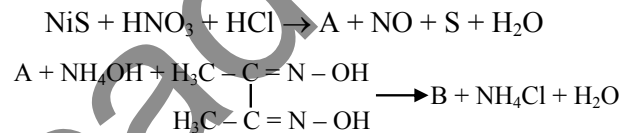

The number of protons that do not involve in hydrogen bonding in the product B is _____.

Ans. (12)

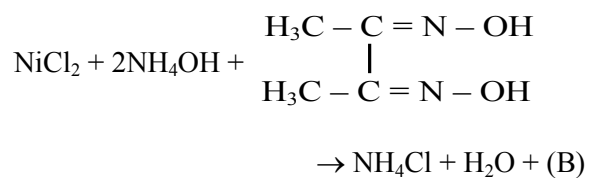
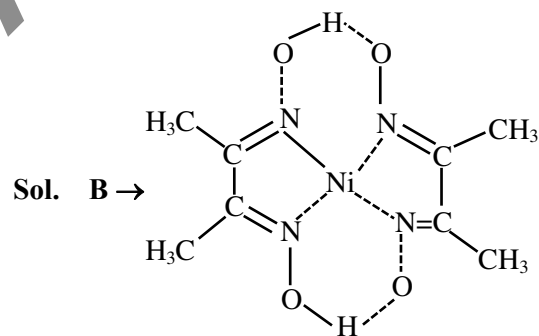

83. When 'x' $\times 10^{-2}$ mL methanol (molar mass = 32 g; density = 0.792 g/cm³) is added to 100 mL water (density = 1 g/cm³), the following diagram is obtained.

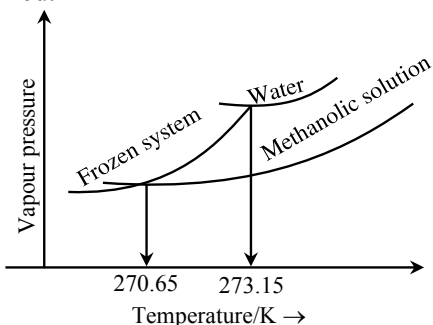

x = (nearest integer)

[Given: Molal freezing point depression constant of water at 273.15 K is 1.86 K kg mol⁻¹]

Ans. (543)

Sol. $\Delta T_f = 273.15 - 270.65 = 2.5$ K

$$\Delta T_f = K_f m \Rightarrow 2.5 = 1.86 \times \frac{n}{0.1}$$

$$\Rightarrow n = 0.1344 \text{ moles}$$

$$\Rightarrow w = 0.1344 \times 32 = 4.3 \text{ g}$$

$$\text{Volume} = \frac{4.3}{0.792} = 5.43 \text{ ml} = 543 \times 10^{-2} \text{ ml}$$

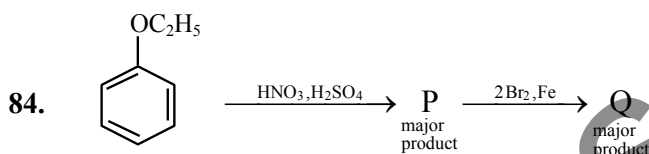

The ratio of number of oxygen atoms to bromine atoms in the product Q is $\text{.....} \times 10^{-1}$.

Ans. (15)

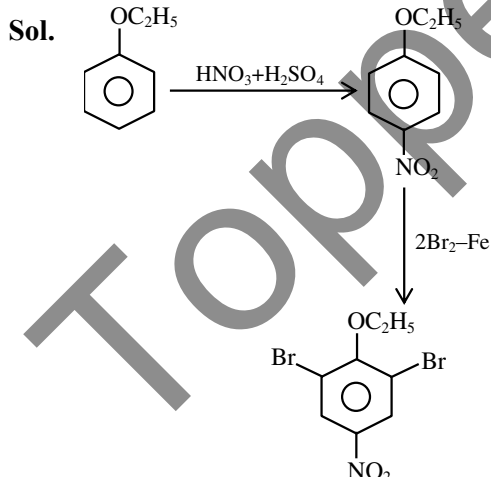

85. Number of carbocation from the following that are **not** stabilized by hyperconjugation is.....

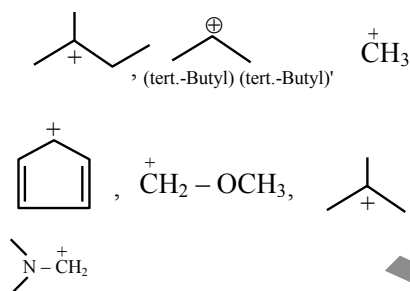

Ans. (5)

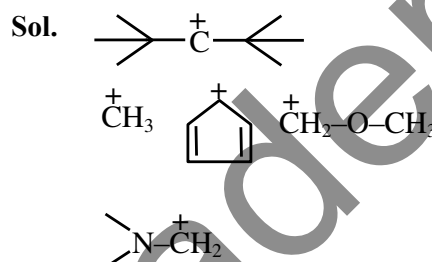

86. For the reaction at 298 K, $2A + B \rightarrow C$. $\Delta H = 400$ kJ mol⁻¹ and $\Delta S = 0.2$ kJ mol⁻¹ K⁻¹. The reaction will become spontaneous above _____ K.

Ans. (2000)

Sol. $\Delta G = 0$

$$T = \frac{\Delta H}{\Delta S} = \frac{400}{0.2} = 2000 \text{ K}$$

87. Total number of species from the following with central atom utilising $2p^2$ hybrid orbitals for bonding is.....

NH₃, SO₂, SiO₂, BeCl₂, C₂H₂, C₂H₄, BCl₃, HCHO, C₆H₆, BF₃, C₂H₄Cl₂

Ans. (6)

Sol. Central atom utilising sp^2 hybrid orbitals

SO₂, C₂H₄, BCl₃, HCHO, C₆H₆, BF₃

88. Consider the two different first order reactions given below

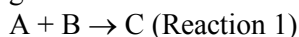

The ratio of the half life of Reaction 1 : Reaction 2 is 5 : 2. If t_1 and t_2 represent the time taken to

complete $\frac{2}{3}$ rd and $\frac{4}{5}$ th of Reaction 1 and

Reaction 2, respectively, then the value of the ratio $t_1 : t_2$ is _____ $\times 10^{-1}$ (nearest integer).

[Given: $\log_{10}(3) = 0.477$ and $\log_{10}(5) = 0.699$]

Ans. (17)

Sol.
$$\frac{(t_{1/2})_I}{(t_{1/2})_{II}} = \frac{K_2}{K_1} = \frac{5}{2}$$

$$\therefore K_1 t_1 = \ln \frac{1}{1 - \frac{2}{3}} = \ln 3$$

$$K_2 t_2 = \ln \frac{1}{1 - \frac{4}{5}} = \ln 5$$

$$\Rightarrow \frac{K_1}{K_2} \times \frac{t_1}{t_2} = \frac{0.477}{0.699}$$

$$\Rightarrow \frac{t_1}{t_2} = \frac{0.477}{0.699} \times \frac{5}{2} = 1.7 = 17 \times 10^{-1}$$

89. For hydrogen atom, energy of an electron in first excited state is -3.4 eV, K.E. of the same electron of hydrogen atom is x eV. Value of x is _____ $\times 10^{-1}$ eV. (Nearest integer)

Ans. (34)

90. Among VO_2^+ , MnO_4^- and $\text{Cr}_2\text{O}_7^{2-}$, the spin-only magnetic moment value of the species with least oxidising ability is.....BM (Nearest integer).

(Given atomic number V = 23, Mn = 25, Cr = 24)

Ans. (0)

Sol. For 3d transition series;

Oxidising power : $\text{V}^{+5} < \text{Cr}^{+6} < \text{Mn}^{+7}$

$\text{V}^{+5} : [\text{Ar}] 4s^0 3d^0$

Number of unpaired electron = 0

$$\mu = 0$$

4. Let $P(x, y, z)$ be a point in the first octant, whose projection in the xy -plane is the point Q . Let $OP = \gamma$; the angle between OQ and the positive x -axis be θ ; and the angle between OP and the positive z -axis be ϕ , where O is the origin. Then the distance of P from the x -axis is :

- (1) $\gamma\sqrt{1 - \sin^2 \phi \cos^2 \theta}$ (2) $\gamma\sqrt{1 + \cos^2 \theta \sin^2 \phi}$
 (3) $\gamma\sqrt{1 - \sin^2 \theta \cos^2 \phi}$ (4) $\gamma\sqrt{1 + \cos^2 \phi \sin^2 \theta}$

Ans. (1)

Sol. $P(x, y, z), Q(x, y, O); x^2 + y^2 + z^2 = \gamma^2$

$$\overline{OQ} = x\hat{i} + y\hat{j}$$

$$\cos\theta = \frac{x}{\sqrt{x^2 + y^2}}$$

$$\cos\phi = \frac{z}{\sqrt{x^2 + y^2 + z^2}}$$

$$\Rightarrow \sin^2\phi = \frac{x^2 + y^2}{x^2 + y^2 + z^2}$$

$$\text{distance of } P \text{ from } x\text{-axis} = \sqrt{y^2 + z^2}$$

$$\Rightarrow \sqrt{\gamma^2 - x^2} \Rightarrow \gamma\sqrt{1 - \frac{x^2}{\gamma^2}}$$

$$= \gamma\sqrt{1 - \cos^2 \theta \sin^2 \phi}$$

5. The number of critical points of the function

$$f(x) = (x - 2)^{2/3} (2x + 1) \text{ is :}$$

- (1) 2 (2) 0
 (3) 1 (4) 3

Ans. (1)

Sol. $f(x) = (x - 2)^{2/3} (2x + 1)$

$$f'(x) = \frac{2}{3}(x - 2)^{-1/3} (2x + 1) + (x - 2)^{2/3} (2)$$

$$f'(x) = 2 \times \frac{(2x + 1) + (x - 2)}{3(x - 2)^{1/3}}$$

$$\frac{3x - 1}{(x - 2)^{1/3}} = 0$$

$$\text{Critical points } x = \frac{1}{3} \text{ and } x = 2$$

6. Let $f(x)$ be a positive function such that the area bounded by $y = f(x), y = 0$ from $x = 0$ to $x = a > 0$ is $e^{-a} + 4a^2 + a - 1$. Then the differential equation, whose general solution is $y = c_1 f(x) + c_2$, where c_1 and c_2 are arbitrary constants, is :

$$(1) (8e^x - 1) \frac{d^2y}{dx^2} + \frac{dy}{dx} = 0$$

$$(2) (8e^x + 1) \frac{d^2y}{dx^2} - \frac{dy}{dx} = 0$$

$$(3) (8e^x + 1) \frac{d^2y}{dx^2} + \frac{dy}{dx} = 0$$

$$(4) (8e^x - 1) \frac{d^2y}{dx^2} - \frac{dy}{dx} = 0$$

Ans. (3)

Sol. $\int_0^a f(x) dx = e^{-a} + 4a^2 + a - 1$

$$f(a) = -e^{-a} + 8a + 1$$

$$f(x) = -e^{-x} + 8x + 1$$

$$\text{Now } y = C_1 f(x) + C_2$$

$$\frac{dy}{dx} = C_1 f'(x) = C_1 (e^{-x} + 8) \quad \dots(1)$$

$$\frac{d^2y}{dx^2} = -C_1 e^{-x} \Rightarrow -e^x \frac{d^2y}{dx^2}$$

Put in equation (1)

$$\frac{dy}{dx} = -e^x \frac{d^2y}{dx^2} (e^{-x} + 8)$$

$$(8e^x + 1) \frac{d^2y}{dx^2} + \frac{dy}{dx} = 0$$

7. Let $f(x) = 4\cos^3 x + 3\sqrt{3}\cos^2 x - 10$. The number of points of local maxima of f in interval $(0, 2\pi)$ is:

- (1) 1 (2) 2
(3) 3 (4) 4

Ans. (2)

Sol. $f(x) = 4\cos^3(x) + 3\sqrt{3}\cos^2(x) - 10 ; x \in (0, 2\pi)$
 $\Rightarrow f'(x) = 12\cos^2 x[-\sin(x)] + 3\sqrt{3}(2\cos(x))[-\sin(x)]$
 $\Rightarrow f'(x) = -6\sin(x)\cos(x)[2\cos(x) + \sqrt{3}]$

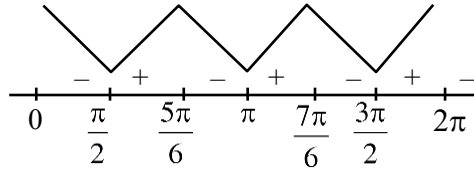

local maxima at $x = \frac{5\pi}{6}, \frac{7\pi}{6}$

8. Let $A = \begin{bmatrix} 2 & a & 0 \\ 1 & 3 & 1 \\ 0 & 5 & b \end{bmatrix}$. If $A^3 = 4A^2 - A - 21I$, where

I is the identity matrix of order 3×3 , then $2a + 3b$ is equal to :

- (1) -10 (2) -13
(3) -9 (4) -12

Ans. (2)

Sol. $A^3 - 4A^2 + A + 21I = 0$
 $\text{tr}(A) = 4 = 5 + 6 \Rightarrow b = -1$
 $|A| = -21$
 $-16 + a = -21 \Rightarrow a = -5$
 $2a + 3b = -13$

9. If the shortest distance between the lines

$$L_1 : \vec{r} = (2 + \lambda)\hat{i} + (1 - 3\lambda)\hat{j} + (3 + 4\lambda)\hat{k}, \lambda \in \mathbb{R}$$

$$L_2 : \vec{r} = 2(1 + \mu)\hat{i} + 3(1 + \mu)\hat{j} + (5 + \mu)\hat{k}, \mu \in \mathbb{R}$$

is $\frac{m}{\sqrt{n}}$, where $\text{gcd}(m, n) = 1$, then the value of

$m + n$ equals.

- (1) 384 (2) 387
(3) 377 (4) 390

Ans. (2)

Sol.

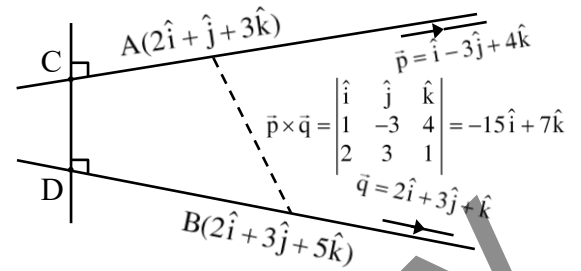

$$\text{Shortest distance (CD)} = \frac{|\overline{AB} \cdot \vec{p} \times \vec{q}|}{|\vec{p} \times \vec{q}|}$$

$$= \frac{|(0\hat{i} + 2\hat{j} + 2\hat{k}) \cdot (-15\hat{i} + 7\hat{j} + 9\hat{k})|}{\sqrt{355}}$$

$$= \frac{0 + 14 + 18}{\sqrt{355}} = \frac{32}{\sqrt{355}}$$

$$\therefore m + n = 32 + 355 = 387$$

10. Let the sum of two positive integers be 24. If the probability, that their product is not less than

$\frac{3}{4}$ times their greatest positive product, is $\frac{m}{n}$,

where $\text{gcd}(m, n) = 1$, then $n - m$ equals :

- (1) 9 (2) 11
(3) 8 (4) 10

Ans. (4)

Sol. $x + y = 24, x, y \in \mathbb{N}$

$$AM > GM \Rightarrow xy \leq 144$$

$$xy \geq 108$$

Favorable pairs of (x, y) are

- (13, 11), (12, 12), (14, 10), (15, 9), (16, 8),
(17, 7), (18, 6), (6, 18), (7, 17), (8, 16), (9, 15),
(10, 14), (11, 13)

i.e. 13 cases

Total choices for $x + y = 24$ is 23

$$\text{Probability} = \frac{13}{23} = \frac{m}{n}$$

$$n - m = 10$$

11. If $\sin x = -\frac{3}{5}$, where $\pi < x < \frac{3\pi}{2}$,

then $80(\tan^2 x - \cos x)$ is equal to :

- (1) 109 (2) 108
(3) 18 (4) 19

Ans. (1)

Sol. $\sin x = -\frac{3}{5}$, $\pi < x < \frac{3\pi}{2}$

$$\tan x = \frac{3}{4} \quad \cos x = -\frac{4}{5}$$

$$80(\tan^2 x - \cos x)$$

$$= 80\left(\frac{9}{16} + \frac{4}{5}\right) = 45 + 64 = 109$$

12. Let $I(x) = \int \frac{6}{\sin^2 x (1 - \cot x)^2} dx$. If $I(0) = 3$, then

$I\left(\frac{\pi}{12}\right)$ is equal to :

- (1) $\sqrt{3}$ (2) $3\sqrt{3}$
(3) $6\sqrt{3}$ (4) $2\sqrt{3}$

Ans. (2)

Sol. $I(x) = \int \frac{6 dx}{\sin^2 x (1 - \cot x)^2} = \int \frac{6 \operatorname{cosec}^2 x dx}{(1 - \cot x)^2}$

Put $1 - \cot x = t$

$\operatorname{cosec}^2 x dx = dt$

$$I = \int \frac{6 dt}{t^2} = \frac{-6}{t} + c$$

$$I(x) = \frac{-6}{1 - \cot x} + c, c = 3$$

$$I(x) = 3 - \frac{6}{1 - \cot x}, I\left(\frac{\pi}{12}\right) = 3 - \frac{6}{1 - (2 + \sqrt{3})}$$

$$I\left(\frac{\pi}{12}\right) = 3 + \frac{6}{\sqrt{3} + 1} = 3 + \frac{6(\sqrt{3} - 1)}{2} = 3\sqrt{3} + \sqrt{2}$$

13. The equations of two sides AB and AC of a triangle ABC are $4x + y = 14$ and $3x - 2y = 5$,

respectively. The point $\left(2, -\frac{4}{3}\right)$ divides the third

side BC internally in the ratio 2 : 1. The equation of the side BC is :

- (1) $x - 6y - 10 = 0$ (2) $x - 3y - 6 = 0$
(3) $x + 3y + 2 = 0$ (4) $x + 6y + 6 = 0$

Ans. (3)

Sol.

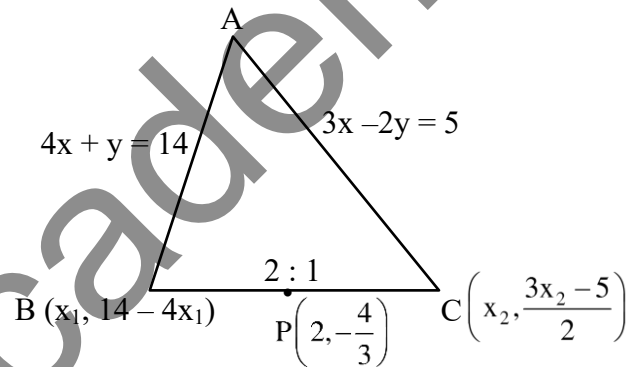

$$\frac{2x_2 + x_1}{3} = 2, \frac{2\left(\frac{3x_2 - 5}{2}\right) + (14 - 4x_1)}{3} = \frac{-4}{3}$$

$$2x_2 + x_1 = 6, 3x_2 - 4x_1 = -13$$

$$x_2 = 1, x_1 = 4$$

So, $C(1, -1), B(4, -2)$

$$m = \frac{-1}{3}$$

$$\text{Equation of BC : } y + 1 = \frac{-1}{3}(x - 1)$$

$$3y + 3 = -x + 1$$

$$x + 3y + 2 = 0$$

14. Let $[t]$ be the greatest integer less than or equal to t . Let A be the set of all prime factors of 2310 and

$$f: A \rightarrow \mathbb{Z} \text{ be the function } f(x) = \left[\log_2 \left(x^2 + \left[\frac{x^3}{5} \right] \right) \right].$$

The number of one-to-one functions from A to the range of f is :

- (1) 20 (2) 120
(3) 25 (4) 24

Ans. (2)

Sol. $N = 2310 = 231 \times 10$

$$= 3 \times 11 \times 7 \times 2 \times 5$$

$$A = \{2, 3, 5, 7, 11\}$$

$$f(x) = \left[\log_2 \left(x^2 + \left[\frac{x^3}{5} \right] \right) \right]$$

$$f(2) = [\log_2(5)] = 2$$

$$f(3) = [\log_2(14)] = 3$$

$$f(5) = [\log_2(25 + 25)] = 5$$

$$f(7) = [\log_2(117)] = 6$$

$$f(11) = [\log_2 387] = 8$$

$$\text{Range of } f: B = \{2, 3, 5, 6, 8\}$$

$$\text{No. of one-one functions} = 5! = 120$$

15. Let z be a complex number such that $|z + 2| = 1$

and $\text{Im} \left(\frac{z+1}{z+2} \right) = \frac{1}{5}$. Then the value of $|\text{Re}(\overline{z+2})|$

is :

- (1) $\frac{\sqrt{6}}{5}$ (2) $\frac{1+\sqrt{6}}{5}$
(3) $\frac{24}{5}$ (4) $\frac{2\sqrt{6}}{5}$

Ans. (4)

Sol. $|z + 2| = 1, \text{Im} \left(\frac{z+1}{z+2} \right) = \frac{1}{5}$

Let $z + 2 = \cos\theta + i\sin\theta$

$$\frac{1}{z+2} = \cos\theta - i\sin\theta$$

$$\Rightarrow \frac{z+1}{z+2} = 1 - \frac{1}{z+2} = 1 - (\cos\theta - i\sin\theta)$$

$$= (1 - \cos\theta) + i\sin\theta$$

$$\text{Im} \left(\frac{z+1}{z+2} \right) = \sin\theta, \sin\theta = \frac{1}{5}$$

$$\cos\theta = \pm \sqrt{1 - \frac{1}{25}} = \pm \frac{2\sqrt{6}}{5}$$

$$|\text{Re}(\overline{z+2})| = \frac{2\sqrt{6}}{5}$$

16. If the set $R = \{(a, b); a + 5b = 42, a, b \in \mathbb{N}\}$

has m elements and $\sum_{n=1}^m (1 + i^{n!}) = x + iy$, where

$I = \sqrt{-1}$, then the value of $m + x + y$ is :

- (1) 8 (2) 12
(3) 4 (4) 5

Ans. (2)

Sol. $a + 5b = 42, a, b \in \mathbb{N}$

$$a = 42 - 5b, b = 1, a = 37$$

$$b = 2, a = 32$$

$$b = 3, a = 27$$

\vdots

$$b = 8, a = 2$$

R has "8" elements $\Rightarrow m = 8$

$$\sum_{n=1}^8 (1 - i^{n!}) = x + iy$$

$$\text{for } n \geq 4, i^{n!} = 1$$

$$\Rightarrow (1 - i) + (1 - i^{2!}) + (1 - i^{3!})$$

$$= 1 - I + 2 + 1 + 1$$

$$= 5 - I = x + iy$$

$$m + x + y = 8 + 5 - 1 = 12$$

17. For the function $f(x) = (\cos x) - x + 1$, $x \in \mathbb{R}$, between the following two statements

(S1) $f(x) = 0$ for only one value of x is $[0, \pi]$.

(S2) $f(x)$ is decreasing in $\left[0, \frac{\pi}{2}\right]$ and increasing in

$\left[\frac{\pi}{2}, \pi\right]$.

- (1) Both (S1) and (S2) are correct
 (2) Only (S1) is correct
 (3) Both (S1) and (S2) are incorrect
 (4) Only (S2) is correct

Ans. (2)

Sol. $f(x) = \cos x - x + 1$

$$f'(x) = -\sin x - 1$$

f is decreasing $\forall x \in \mathbb{R}$

$$f(x) = 0$$

$$f(0) = 2, f(\pi) = -\pi$$

f is strictly decreasing in $[0, \pi]$ and $f(0) \cdot f(\pi) < 0$

\Rightarrow only one solution of $f(x) = 0$

S1 is correct and S2 is incorrect.

18. The set of all α , for which the vector

$$\vec{a} = \alpha \hat{i} + 6\hat{j} - 3\hat{k} \quad \text{and} \quad \vec{b} = \hat{i} - 2\hat{j} - 2\alpha \hat{k}$$

are inclined at an obtuse angle for all $t \in \mathbb{R}$ is :

- (1) $[0, 1)$ (2) $(-2, 0]$

- (3) $\left(-\frac{4}{3}, 0\right]$ (4) $\left(-\frac{4}{3}, 1\right)$

Ans. (3)

Sol. $\vec{a} = \alpha \hat{i} + 6\hat{j} - 3\hat{k}$

$$\vec{b} = \hat{i} - 2\hat{j} - 2\alpha \hat{k}$$

so $\vec{a} \cdot \vec{b} < 0, \forall t \in \mathbb{R}$

$$\alpha t^2 - 12 + 6\alpha t < 0$$

$$\alpha t^2 + 6\alpha t - 12 < 0, \forall t \in \mathbb{R}$$

$$\alpha < 0, \text{ and } D < 0$$

$$36\alpha^2 + 48\alpha < 0$$

$$12\alpha(3\alpha + 4) < 0$$

$$\frac{-4}{3} < \alpha < 0$$

also for $\alpha = 0, \vec{a} \cdot \vec{b} < 0$

$$\text{hence } \alpha \in \left(-\frac{4}{3}, 0\right]$$

19. Let $y = y(x)$ be the solution of the differential equation $(1 + y^2)e^{\tan x} dx + \cos^2 x(1 + e^{2\tan x}) dy = 0$,

$y(0) = 1$. Then $y\left(\frac{\pi}{4}\right)$ is equal to :

- (1) $\frac{2}{e}$ (2) $\frac{1}{e^2}$
 (3) $\frac{1}{e}$ (4) $\frac{2}{e^2}$

Ans. (3)

Sol. $(1 + y^2)e^{\tan x} dx + \cos^2 x(1 + e^{2\tan x}) dy = 0$

$$\int \frac{\sec^2 x e^{\tan x}}{1 + e^{2\tan x}} dx + \int \frac{dy}{1 + y^2} = C$$

$$\Rightarrow \tan^{-1}(e^{\tan x}) + \tan^{-1} y = C$$

$$\text{for } x = 0, y = 1, \tan^{-1}(1) + \tan^{-1} 1 = C$$

$$C = \frac{\pi}{2}$$

$$\tan^{-1}(e^{\tan x}) + \tan^{-1} y = \frac{\pi}{2}$$

$$\text{Put } x = \frac{\pi}{4}, \tan^{-1} e + \tan^{-1} y = \frac{\pi}{2}$$

$$\tan^{-1} y = \cot^{-1} e$$

$$y = \frac{1}{e}$$

20. Let $H : \frac{-x^2}{a^2} + \frac{y^2}{b^2} = 1$ be the hyperbola, whose

eccentricity is $\sqrt{3}$ and the length of the latus rectum is $4\sqrt{3}$. Suppose the point $(\alpha, 6)$, $\alpha > 0$ lies on H . If β is the product of the focal distances of the point $(\alpha, 6)$, then $\alpha^2 + \beta$ is equal to :

- (1) 170 (2) 171
 (3) 169 (4) 172

Ans. (2)

Sol. H : $\frac{y^2}{b^2} - \frac{x^2}{a^2} = 1$, $e = \sqrt{3}$

$$e = \sqrt{1 + \frac{a^2}{b^2}} = \sqrt{3} \Rightarrow \frac{a^2}{b^2} = 2$$

$$a^2 = 2b^2$$

$$\text{length of L.R.} = \frac{2a^2}{b} = 4\sqrt{3}$$

$$a = \sqrt{6}$$

$$P(\alpha, 6) \text{ lie on } \frac{y^2}{3} - \frac{x^2}{6} = 1$$

$$12 - \frac{\alpha^2}{6} = 1 \Rightarrow \alpha^2 = 66$$

$$\text{Foci} = (0, \pm be) = (0, 3) \text{ \& } (0, -3)$$

Let d_1 & d_2 be focal distances of $P(\alpha, 6)$

$$d_1 = \sqrt{\alpha^2 + (6+be)^2}, d_2 = \sqrt{\alpha^2 + (6-be)^2}$$

$$d_1 = \sqrt{66+81}, d_2 = \sqrt{66+9}$$

$$\beta = d_1 d_2 = \sqrt{147 \times 75} = 105$$

$$\alpha^2 + \beta = 66 + 105 = 171$$

SECTION-B

21. Let $A = \begin{bmatrix} 2 & -1 \\ 1 & 1 \end{bmatrix}$. If the sum of the diagonal elements of A^{13} is 3^n , then n is equal to _____.

Ans. (7)

Sol. $A = \begin{bmatrix} 2 & -1 \\ 1 & 1 \end{bmatrix}$

$$A^2 = \begin{bmatrix} 2 & -1 \\ 1 & 1 \end{bmatrix} \begin{bmatrix} 2 & -1 \\ 1 & 1 \end{bmatrix} = \begin{bmatrix} 3 & -3 \\ 3 & 0 \end{bmatrix}$$

$$A^3 = \begin{bmatrix} 3 & -3 \\ 3 & 0 \end{bmatrix} \begin{bmatrix} 2 & -1 \\ 1 & 1 \end{bmatrix} = \begin{bmatrix} 3 & -6 \\ 6 & -3 \end{bmatrix}$$

$$A^4 = \begin{bmatrix} 3 & -6 \\ 6 & -3 \end{bmatrix} \begin{bmatrix} 2 & -1 \\ 1 & 1 \end{bmatrix} = \begin{bmatrix} 0 & -9 \\ 9 & -9 \end{bmatrix}$$

$$A^5 = \begin{bmatrix} 0 & -9 \\ 9 & -9 \end{bmatrix} \begin{bmatrix} 2 & -1 \\ 1 & 1 \end{bmatrix} = \begin{bmatrix} -9 & -9 \\ 9 & -18 \end{bmatrix}$$

$$A^6 = \begin{bmatrix} -9 & -9 \\ 9 & -18 \end{bmatrix} \begin{bmatrix} 2 & -1 \\ 1 & 1 \end{bmatrix} = \begin{bmatrix} -27 & 0 \\ 0 & -27 \end{bmatrix}$$

$$A^7 = \begin{bmatrix} -27 & 0 \\ 0 & -27 \end{bmatrix} \begin{bmatrix} -54 & 27 \\ -27 & -27 \end{bmatrix} = \begin{bmatrix} 3^6 \times 2 & -27^2 \\ 27^2 & 3^6 \end{bmatrix}$$

$$3^7 = 3^n \Rightarrow n = 7$$

22. If the orthocentre of the triangle formed by the lines $2x + 3y - 1 = 0$, $x + 2y - 1 = 0$ and $ax + by - 1 = 0$, is the centroid of another triangle, whose circumcentre and orthocentre respectively are $(3, 4)$ and $(-6, -8)$, then the value of $|a - b|$ is _____.

Ans. (16)

Sol. $2x + 3y - 1 = 0$

$$x + 2y - 1 = 0$$

$$ax + by - 1 = 0$$

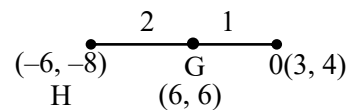

$$\left(\frac{6-6}{3}, \frac{8-8}{3} \right)$$

$$= (0, 0)$$

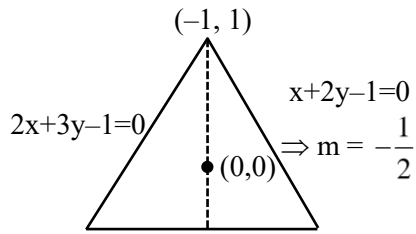

$$ax + by - 1 = 0$$

$$\left(\frac{1-0}{-1-0}\right)\left(\frac{-a}{b}\right) = -1$$

$$\Rightarrow -a = b$$

$$\Rightarrow ax - ay - 1 = 0$$

$$ax - a\left(1 - \frac{2x}{3}\right) - 1 = 0$$

$$x\left(a + \frac{2a}{3}\right) = \frac{a}{3}$$

$$x = \frac{a+3}{5a}$$

$$2\left(\frac{a+3}{5a}\right) + 3y - 1 = 0$$

$$y = \frac{1 - \frac{2a+6}{5a}}{3} = \frac{3a-6}{3 \times 5a}$$

$$y = \frac{a-2}{5a}$$

$$\frac{\left(\frac{a-2}{5a}\right)}{\left(\frac{a+3}{5a}\right)} = 2 \Rightarrow a-2 = 2a+6$$

$$a = -8$$

$$b = 8$$

$$-8x + 8y - 1 = 0$$

$$|a - b| = 16$$

23. Three balls are drawn at random from a bag containing 5 blue and 4 yellow balls. Let the random variables X and Y respectively denote the number of blue and Yellow balls. If \bar{X} and \bar{Y} are the means of X and Y respectively, then $7\bar{X} + 4\bar{Y}$ is equal to _____.

Ans. (17)

Sol.

Blue balls	0	1	2	3	4	5
Prob.	$\frac{{}^5C_0 \cdot {}^4C_1}{{}^9C_3}$	$\frac{{}^5C_1 \cdot {}^4C_2}{{}^9C_3}$	$\frac{{}^5C_2 \cdot {}^4C_1}{{}^9C_3}$	$\frac{{}^5C_3 \cdot {}^4C_0}{{}^9C_3}$	0	0

$$7\bar{X} = \frac{{}^5C_1 \cdot {}^4C_2 + {}^5C_2 \cdot {}^4C_1 \times 2 + {}^5C_3 \cdot {}^4C_0 \times 3}{{}^9C_3} \times 7$$

$$= \frac{30 + 80 + 30}{84} \times 7$$

$$= \frac{140}{12} = \frac{70}{6} = \frac{35}{3}$$

yellow	0	1	2	3	4
		${}^5C_2 \cdot {}^4C_1$	${}^5C_1 \cdot {}^4C_2$	${}^5C_0 \cdot {}^4C_3$	0

$$4\bar{Y} = \frac{40 + 60 + 12}{84} \times 4 = \frac{112}{21} = \frac{16}{3}$$

24. The number of 3-digit numbers, formed using the digits 2, 3, 4, 5 and 7, when the repetition of digits is not allowed, and which are not divisible by 3, is equal to _____.

Ans. (36)

Sol. 2, 3, 4, 5, 7

total number of three digit numbers not divisible by 3 will be formed by using the digits

(4, 5, 7)

(3, 4, 7)

(2, 5, 7)

(2, 4, 7)

(2, 4, 5)

(2, 3, 5)

number of ways = $6 \times 3! = 36$

25. Let the positive integers be written in the form :

$$\begin{array}{ccccccc}
 & & & & & & 1 \\
 & & & & & & 2 & 3 \\
 & & & & & & 4 & 5 & 6 \\
 & & & & & & \vdots & 7 & 8 & 9 & 10 & \vdots
 \end{array}$$

If the k^{th} row contains exactly k numbers for every natural number k , then the row in which the number 5310 will be, is _____.

Ans. (103)

Sol. $S = 1 + 2 + 4 + 7 + \dots + T_n$

$$S = 1 + 2 + 4 + \dots$$

$$T_n = 1 + 1 + 2 + 3 + \dots + (T_n - T_{n-1})$$

$$T_n = 1 + \left(\frac{n-1}{2}\right)[2 + (n-2) \times 1]$$

$$T_n = 1 + 1 + \frac{n(n-1)}{2}$$

$$n = 100 \quad T_n = 1 + \frac{100 \times 99}{2} = 4950 + 1$$

$$n = 101 \quad T_n = 1 + \frac{101 \times 100}{2} = 5050 + 1 = 5051$$

$$n = 102 \quad T_n = 1 + \frac{102 \times 101}{2} = 5151 + 1 = 5152$$

$$n = 103 \quad T_n = 1 + \frac{103 \times 102}{2} = 5254$$

$$n = 104 \quad T_n = 1 + \frac{104 \times 103}{2} = 5357$$

26. If the range of $f(\theta) = \frac{\sin^4 \theta + 3 \cos^2 \theta}{\sin^4 \theta + \cos^2 \theta}$, $\theta \in \mathbb{R}$ is

$[\alpha, \beta]$, then the sum of the infinite G.P., whose first term is 64 and the common ratio is $\frac{\alpha}{\beta}$, is equal to _____.

Ans. (96)

Sol. $f(\theta) = \frac{\sin^4 \theta + 3 \cos^2 \theta}{\sin^4 \theta + \cos^2 \theta}$

$$f(\theta) = 1 + \frac{2 \cos^2 \theta}{\sin^4 \theta + \cos^2 \theta}$$

$$f(\theta) = \frac{2 \cos^2 \theta}{\cos^4 \theta - \cos^2 \theta + 1} + 1$$

$$f(\theta) = \frac{2}{\cos^2 \theta + \sec^2 \theta - 1} + 1$$

$$f(\theta)|_{\min.} = 1$$

$$f(\theta)|_{\max.} = 3$$

$$S = \frac{64}{1 - 1/3} = 96$$

27. Let $\alpha = \sum_{r=0}^n (4r^2 + 2r + 1)^n C_r$ and $\beta = \left(\sum_{r=0}^n \frac{{}^n C_r}{r+1} \right) + \frac{1}{n+1}$. If $140 < \frac{2\alpha}{\beta} < 281$,

then the value of n is _____.

Ans. (5)

Sol. $\alpha = \sum_{r=0}^n (4r^2 + 2r + 1)^n C_r$

$$\alpha = 4 \sum_{r=0}^n r^2 \cdot \frac{n}{r} \cdot {}^{n-1} C_{r-1} + 2 \sum_{r=0}^n r \cdot \frac{n}{r} \cdot {}^{n-1} C_{r-1} + \sum_{r=0}^n {}^n C_r$$

$$+ 4n \sum_{r=0}^n {}^{n-1} C_{r-1} + 2n \sum_{r=0}^n {}^{n-1} C_{r-1} + \sum_{r=0}^n {}^n C_r$$

$$\alpha = 4n(n-1) \cdot 2^{n-2} + 4n \cdot 2^{n-1} + 2n \cdot 2^{n-1} + 2^n$$

$$\alpha = 2^{n-2} [4n(n-1) + 8n + 4n + 4]$$

$$\alpha = 2^{n-2} [4n^2 + 8n + 4]$$

$$\alpha = 2n(n+1)^2$$

$$\beta = \sum_{r=0}^n \frac{{}^n C_r}{r+1} + \frac{1}{n+1}$$

$$= \sum_{r=0}^n \frac{{}^{n+1} C_{r+1}}{n+1} + \frac{1}{n+1}$$

$$= \frac{1}{n+1} (1 + {}^{n+1} C_1 + \dots + {}^{n+1} C_{n+1})$$

$$= \frac{2^{n+1}}{n+1}$$

$$\frac{2\alpha}{\beta} = \frac{2^{n+1} (n+1)^2}{2^{n+1}} \cdot (n+1) = (n+1)^3$$

$$140 < (n+1)^3 < 281$$

$$n = 4 \Rightarrow (n+1)^3 = 125$$

$$n = 5 \Rightarrow (n+1)^3 = 216$$

$$n = 6 \Rightarrow (n+1)^3 = 343$$

$$\therefore n = 5$$

28. Let $\vec{a} = 9\hat{i} - 13\hat{j} + 25\hat{k}$, $\vec{b} = 3\hat{i} + 7\hat{j} - 13\hat{k}$ and $\vec{c} = 17\hat{i} - 2\hat{j} + \hat{k}$ be three given vectors. If \vec{r} is a vector such that $\vec{r} \times \vec{a} = (\vec{b} + \vec{c}) \times \vec{a}$ and $\vec{r} \cdot (\vec{b} - \vec{c}) = 0$, then $\frac{|593\vec{r} + 67\vec{a}|^2}{(593)^2}$ is equal to _____.

Ans. (569)

Sol. $\vec{a} = 9\hat{i} - 13\hat{j} + 25\hat{k}$

$\vec{b} = 3\hat{i} + 7\hat{j} - 13\hat{k}$

$\vec{c} = 17\hat{i} - 2\hat{j} + \hat{k}$

$\vec{b} + \vec{c} = 20\hat{i} + 5\hat{j} - 12\hat{k}$

$\vec{b} - \vec{c} = -14\hat{i} + 9\hat{j} - 14\hat{k}$

$(\vec{r} - (\vec{b} + \vec{c})) \times \vec{a} = 0$

$\vec{r} - (\vec{b} + \vec{c}) = \lambda \vec{a}$

$\vec{r} = \lambda \vec{a} + \vec{b} + \vec{c}$

But $\vec{r} \cdot (\vec{b} - \vec{c}) = 0$

$\Rightarrow (\lambda \vec{a} + \vec{b} + \vec{c}) \cdot (\vec{b} - \vec{c}) = 0$

$\Rightarrow \lambda \vec{a} \cdot \vec{b} + \vec{b} \cdot \vec{b} + \vec{c} \cdot \vec{b} - \lambda \vec{a} \cdot \vec{c} - \vec{b} \cdot \vec{c} - \vec{c} \cdot \vec{c} = 0$

$\lambda = \frac{\vec{c} \cdot \vec{c} - \vec{b} \cdot \vec{b}}{\vec{a} \cdot \vec{b} - \vec{a} \cdot \vec{c}} = \frac{294 - 227}{-389 - 204} = \frac{-67}{593}$

$\therefore \vec{r} = \vec{b} + \vec{c} - \frac{67}{593} \vec{a}$

$\Rightarrow 593\vec{r} + 67\vec{a} = 593(\vec{b} + \vec{c})$

$\Rightarrow |\vec{b} + \vec{c}|^2 = 569$

29. Let the area of the region enclosed by the curve $y = \min\{\sin x, \cos x\}$ and the x-axis between $x = -\pi$ to $x = \pi$ be A. Then A^2 is equal to _____.

Ans. (16)

Sol. $y = \min\{\sin x, \cos x\}$
 x -axis $x = -\pi$ $x = \pi$

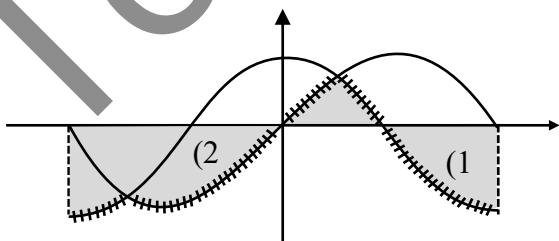

$$\int_0^{\pi/4} \sin x = (\cos x)_{\pi/4}^0 = 1 - \frac{1}{\sqrt{2}}$$

$$\int_{-\pi}^{-3\pi/4} (\sin x - \cos x) = (-\cos x - \sin x)_{-\pi}^{-3\pi/4}$$

$$= (\cos x + \sin x)_{-3\pi/4}^{-\pi}$$

$$= (-1 + 0) - \left(-\frac{1}{\sqrt{2}} - \frac{1}{\sqrt{2}}\right)$$

$$= -1 + \frac{1}{\sqrt{2}} + \frac{1}{\sqrt{2}}$$

$$\int_{\pi/4}^{\pi/2} \cos x dx = (\sin x)_{\pi/4}^{\pi/2} = 1 - \frac{1}{\sqrt{2}}$$

$$A = 4$$

$$A^2 = 16$$

30. The value of

$$\lim_{x \rightarrow 0} 2 \left(\frac{1 - \cos x \sqrt{\cos 2x} \sqrt[3]{\cos 3x} \dots \sqrt[10]{\cos 10x}}{x^2} \right)$$
 is

_____.

Ans. (55)

Sol.

$$\lim_{x \rightarrow 0} 2 \left(\frac{\left(1 - \left(1 - \frac{x^2}{2!}\right)\right) \left(1 - \frac{4x^2}{2!}\right) \left(1 - \frac{9x^2}{2!}\right) \dots \left(1 - \frac{100x^2}{2!}\right)}{x^2} \right)$$

By expansion

$$\lim_{x \rightarrow 0} \frac{2 \left(1 - \left(1 - \frac{x^2}{2}\right)\right) \left(1 - \frac{1}{2} \cdot \frac{4x^2}{2}\right) \left(1 - \frac{1}{3} \cdot \frac{9x^2}{2}\right) \dots \left(1 - \frac{1}{10} \cdot \frac{100x^2}{2}\right)}{x^2}$$

$$\lim_{x \rightarrow 0} \frac{2 \left(1 - \left(1 - \frac{x^2}{2}\right)\right) \left(1 - \frac{2x^2}{2}\right) \left(1 - \frac{3x^2}{2}\right) \dots \left(1 - \frac{10x^2}{2}\right)}{x^2}$$

$$\lim_{x \rightarrow 0} \frac{2 \left(1 - 1 + x^2 \left(\frac{1}{2} + \frac{2}{2} + \frac{3}{2} + \dots + \frac{10}{2}\right)\right)}{x^2}$$

$$2 \left(\frac{1}{2} + \frac{2}{2} + \frac{3}{2} + \dots + \frac{10}{2}\right)$$

$$1 + 2 + \dots + 10 = \frac{10 \times 11}{2} = 55$$

PHYSICS

TEST PAPER WITH SOLUTION

SECTION-A

31. Three bodies A, B and C have equal kinetic energies and their masses are 400 g, 1.2 kg and 1.6 kg respectively. The ratio of their linear momenta is :

- (1) $1:\sqrt{3}:2$ (2) $1:\sqrt{3}:\sqrt{2}$
 (3) $\sqrt{2}:\sqrt{3}:1$ (4) $\sqrt{3}:\sqrt{2}:1$

Ans. (1)

Sol. $KE = \frac{P^2}{2m}$

$P \propto \sqrt{m}$

Hence, $P_A : P_B : P_C$

$= \sqrt{400} : \sqrt{1200} : \sqrt{1600} = 1 : \sqrt{3} : 2$

32. Average force exerted on a non-reflecting surface at normal incidence is $2.4 \times 10^{-4} \text{N}$. If 360 W/cm^2 is the light energy flux during span of 1 hour 30 minutes. Then the area of the surface is:

- (1) 0.2 m^2 (2) 0.02 m^2
 (3) 20 m^2 (4) 0.1 m^2

Ans. (2)

Sol. Pressure = $\frac{I}{C} = \frac{F}{A}$

$\Rightarrow \frac{360}{10^{-4} \times 3 \times 10^8} = \frac{2.4 \times 10^{-4}}{A}$

$\Rightarrow A = 2 \times 10^{-2} \text{ m}^2 = 0.02 \text{ m}^2$

33. A proton and an electron are associated with same de-Broglie wavelength. The ratio of their kinetic energies is:

(Assume $h = 6.63 \times 10^{-34} \text{ J s}$, $m_e = 9.0 \times 10^{-31} \text{ kg}$ and $m_p = 1836 \text{ times } m_e$)

- (1) $1 : 1836$ (2) $1 : \frac{1}{1836}$
 (3) $1 : \frac{1}{\sqrt{1836}}$ (4) $1 : \sqrt{1836}$

Ans. (1)

Sol. λ is same for both

$P = \frac{h}{\lambda}$ same for both

$P = \sqrt{2mK}$

Hence,

$K \propto \frac{1}{m}$

$\Rightarrow \frac{KE_p}{KE_e} = \frac{m_e}{m_p} = \frac{1}{1836}$

34. A mixture of one mole of monoatomic gas and one mole of a diatomic gas (rigid) are kept at room temperature (27°C). The ratio of specific heat of gases at constant volume respectively is:

- (1) $\frac{7}{5}$ (2) $\frac{3}{2}$
 (3) $\frac{3}{5}$ (4) $\frac{5}{3}$

Ans. (3)

Sol. $\frac{(C_v)_{\text{mono}}}{(C_v)_{\text{dia}}} = \frac{\frac{3}{2}R}{\frac{5}{2}R} = \frac{3}{5}$

35. In an expression $a \times 10^b$:

- (1) a is order of magnitude for $b \leq 5$
 (2) b is order of magnitude for $a \leq 5$
 (3) b is order of magnitude for $5 < a \leq 10$
 (4) b is order of magnitude for $a \geq 5$

Ans. (2)

Sol. $a \times 10^b$

if $a \leq 5$ order is b

$a > 5$ order is $b + 1$

36. In the given circuit, the terminal potential difference of the cell is :

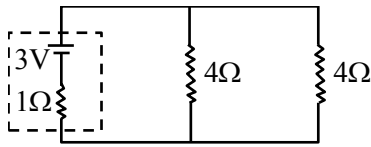

- (1) 2 V (2) 4 V
(3) 1.5 V (4) 3 V

Ans. (1)

Sol.

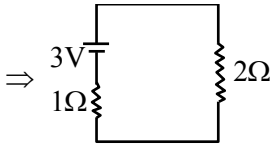
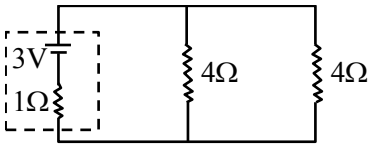

$$i = \frac{3}{1+2} = 1\text{A}$$

$$v = E - ir$$

$$= 3 - 1 \times 1 = 2\text{V}$$

37. Binding energy of a certain nucleus is 18×10^8 J. How much is the difference between total mass of all the nucleons and nuclear mass of the given nucleus:

- (1) 0.2 μg (2) 20 μg
(3) 2 μg (4) 10 μg

Ans. (2)

Sol. $\Delta mc^2 = 18 \times 10^8$

$$\Delta m \times 9 \times 10^{16} = 18 \times 10^8$$

$$\Delta m = 2 \times 10^{-8} \text{kg} = 20 \mu\text{g}$$

38. Paramagnetic substances:

- A. align themselves along the directions of external magnetic field.
B. attract strongly towards external magnetic field.
C. has susceptibility little more than zero.
D. move from a region of strong magnetic field to weak magnetic field.

Choose the **most appropriate** answer from the options given below:

- (1) A, B, C, D (2) B, D Only
(3) A, B, C Only (4) A, C Only

Ans. (4)

Sol. A, C only

39. A clock has 75 cm, 60 cm long second hand and minute hand respectively. In 30 minutes duration the tip of second hand will travel x distance more than the tip of minute hand. The value of x in meter is nearly (Take $\pi = 3.14$):

- (1) 139.4 (2) 140.5
(3) 220.0 (4) 118.9

Ans. (1)

Sol. $x_{\min} = \pi \times r_{\min}$

$$= \pi \times \frac{60}{100} \text{m.}$$

$$x_{\text{second}} = 30 \times 2\pi \times r_{\text{second}}$$

$$= 30 \times 2\pi \times \frac{75}{100}$$

$$x = x_{\text{second}} - x_{\min}$$

$$= 139.4 \text{ m}$$

40. Young's modulus is determined by the equation given by $Y = 49000 \frac{\text{m dyne}}{\ell \text{ cm}^2}$ where M is the mass

and ℓ is the extension of wire used in the experiment. Now error in Young modulus(Y) is estimated by taking data from M- ℓ plot in graph paper. The smallest scale divisions are 5 g and 0.02 cm along load axis and extension axis respectively. If the value of M and ℓ are 500 g and 2 cm respectively then percentage error of Y is :

- (1) 0.2 % (2) 0.02 %
(3) 2 % (4) 0.5 %

Ans. (3)

Sol. $\frac{\Delta Y}{Y} = \frac{\Delta m}{m} + \frac{\Delta \ell}{\ell}$
 $= \frac{5}{500} + \frac{0.02}{2} = 0.01 + 0.01$
 $\frac{\Delta Y}{Y} = 0.02 \Rightarrow \% \frac{\Delta Y}{Y} = 2\%$

41. Two different adiabatic paths for the same gas intersect two isothermal curves as shown in P-V diagram. The relation between the ratio $\frac{V_a}{V_d}$ and the

ratio $\frac{V_b}{V_c}$ is:

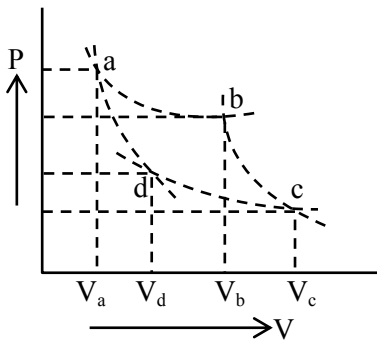

- (1) $\frac{V_a}{V_d} = \left(\frac{V_b}{V_c}\right)^{-1}$ (2) $\frac{V_a}{V_d} \neq \frac{V_b}{V_c}$
 (3) $\frac{V_a}{V_d} = \frac{V_b}{V_c}$ (4) $\frac{V_a}{V_d} = \left(\frac{V_b}{V_c}\right)^2$

Ans. (3)

Sol. For adiabatic process

$$TV^{\gamma-1} = \text{constant}$$

$$T_a \cdot V_a^{\gamma-1} = T_d \cdot V_d^{\gamma-1}$$

$$\left(\frac{V_a}{V_d}\right)^{\gamma-1} = \frac{T_d}{T_a}$$

$$T_b \cdot V_b^{\gamma-1} = T_c \cdot V_c^{\gamma-1}$$

$$\left(\frac{V_b}{V_c}\right)^{\gamma-1} = \frac{T_c}{T_b}$$

$$\frac{V_a}{V_d} = \frac{V_b}{V_c} \quad \left(\begin{array}{l} \because T_d = T_c \\ T_a = T_b \end{array} \right)$$

42. Two planets A and B having masses m_1 and m_2 move around the sun in circular orbits of r_1 and r_2 radii respectively. If angular momentum of A is L and that of B is $3L$, the ratio of time period $\left(\frac{T_A}{T_B}\right)$ is:

- (1) $\left(\frac{r_2}{r_1}\right)^{\frac{3}{2}}$ (2) $\left(\frac{r_1}{r_2}\right)^3$
 (3) $\frac{1}{27} \left(\frac{m_2}{m_1}\right)^3$ (4) $27 \left(\frac{m_1}{m_2}\right)^3$

Ans. (3)

Sol. $\frac{\pi r_1^2}{T_A} = \frac{L}{2m_1}$ (1)

$$\frac{\pi r_2^2}{T_B} = \frac{3L}{2m_2}$$
 (2)

$$\Rightarrow \frac{T_A}{T_B} = 3 \cdot \frac{m_1}{m_2} \left(\frac{r_1}{r_2}\right)^2$$

$$\left(\frac{T_A}{T_B}\right)^2 = \left(\frac{r_1}{r_2}\right)^3 \Rightarrow \left(\frac{r_1}{r_2}\right)^2 = \left(\frac{T_A}{T_B}\right)^{\frac{4}{3}}$$

$$\Rightarrow \frac{1}{27} \cdot \left(\frac{m_2}{m_1}\right)^3 = \left(\frac{T_A}{T_B}\right)$$

43. A LCR circuit is at resonance for a capacitor C , inductance L and resistance R . Now the value of resistance is halved keeping all other parameters same. The current amplitude at resonance will be now:

- (1) Zero (2) double
 (3) same (4) halved

Ans. (2)

Sol. In resonance $Z = R$

$$I = \frac{V}{R}$$

$R \rightarrow$ halved

$$\Rightarrow I \rightarrow 2I$$

I becomes doubled.

44. The output Y of following circuit for given inputs is :

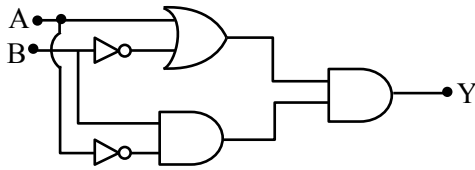

- (1) $A \cdot B(A + B)$ (2) $A \cdot B$
 (3) 0 (4) $\bar{A} \cdot B$

Ans. (3)

Sol. By truth table

A	B	Y
0	0	0
0	1	0
1	0	0
1	1	0

45. Two charged conducting spheres of radii a and b are connected to each other by a conducting wire. The ratio of charges of the two spheres respectively is:

- (1) \sqrt{ab} (2) ab
 (3) $\frac{a}{b}$ (4) $\frac{b}{a}$

Ans. (3)

Sol. Potential at surface will be same

$$\frac{Kq_1}{a} = \frac{Kq_2}{b}$$

$$\frac{q_1}{q_2} = \frac{a}{b}$$

46. Correct Bernoulli's equation is (symbols have their usual meaning) :

- (1) $P + mgh + \frac{1}{2}mv^2 = \text{constant}$
 (2) $P + \rho gh + \frac{1}{2}\rho v^2 = \text{constant}$
 (3) $P + \rho gh + \rho v^2 = \text{constant}$
 (4) $P + \frac{1}{2}\rho gh + \frac{1}{2}\rho v^2 = \text{constant}$

Ans. (2)

Sol. $P + \rho gh + \frac{1}{2}\rho v^2 = \text{constant}$

47. A player caught a cricket ball of mass 150 g moving at a speed of 20 m/s. If the catching process is completed in 0.1 s, the magnitude of force exerted by the ball on the hand of the player is:

- (1) 150 N (2) 3 N
 (3) 30 N (4) 300 N

Ans. (3)

Sol. $F = \frac{\Delta P}{\Delta t} = \frac{mv - 0}{0.1}$
 $= \frac{150 \times 10^{-3} \times 20}{0.1} = 30 \text{ N}$

48. A stationary particle breaks into two parts of masses m_A and m_B which move with velocities v_A and v_B respectively. The ratio of their kinetic energies ($K_B : K_A$) is :

- (1) $v_B : v_A$ (2) $m_B : m_A$
 (3) $m_B v_B : m_A v_A$ (4) 1 : 1

Ans. (1)

Sol. Initial momentum is zero.

Hence $|P_A| = |P_B|$

$\Rightarrow m_A v_B = m_B v_A$

$$\frac{(KE)_A}{(KE)_B} = \frac{\frac{1}{2}m_A v_A^2}{\frac{1}{2}m_B v_B^2} = \frac{v_A}{v_B}$$

$$\frac{(KE)_B}{(KE)_A} = \frac{v_B}{v_A}$$

49. Critical angle of incidence for a pair of optical media is 45° . The refractive indices of first and second media are in the ratio:

- (1) $\sqrt{2} : 1$ (2) 1 : 2
 (3) $1 : \sqrt{2}$ (4) 2 : 1

Ans. (1)

Sol. $\sin\theta_c = \frac{\mu_R}{\mu_d} = \frac{\mu_2}{\mu_1}$

$\sin 45^\circ = \frac{\mu_2}{\mu_1}$

$\Rightarrow \frac{1}{\sqrt{2}} = \frac{\mu_2}{\mu_1}$

$\Rightarrow \frac{\mu_1}{\mu_2} = \frac{\sqrt{2}}{1}$

50. The diameter of a sphere is measured using a vernier caliper whose 9 divisions of main scale are equal to 10 divisions of vernier scale. The shortest division on the main scale is equal to 1 mm. The main scale reading is 2 cm and second division of vernier scale coincides with a division on main scale. If mass of the sphere is 8.635 g, the density of the sphere is:

- (1) 2.5 g/cm³ (2) 1.7 g/cm³
 (3) 2.2 g/cm³ (4) 2.0 g/cm³

Ans. (4)

Sol. Given 9MSD = 10VSD

mass = 8.635 g

LC = 1 MSD – 1 VSD

LC = 1 MSD – $\frac{9}{10}$ MSD

LC = $\frac{1}{10}$ MSD

LC = 0.01 cm

Reading of diameter = MSR + LC × VSR

= 2 cm + (0.01) × (2)

= 2.02 cm

Volume of sphere = $\frac{4}{3}\pi\left(\frac{d}{2}\right)^3 = \frac{4}{3}\pi\left(\frac{2.02}{2}\right)^3$
 = 4.32 cm³

Density = $\frac{\text{mass}}{\text{volume}} = \frac{8.635}{4.32} = 1.998 \sim 2.00\text{g}$

SECTION-B

51. A uniform thin metal plate of mass 10 kg with dimensions is shown. The ratio of x and y coordinates of center of mass of plate in $\frac{n}{9}$. The value of n is _____.

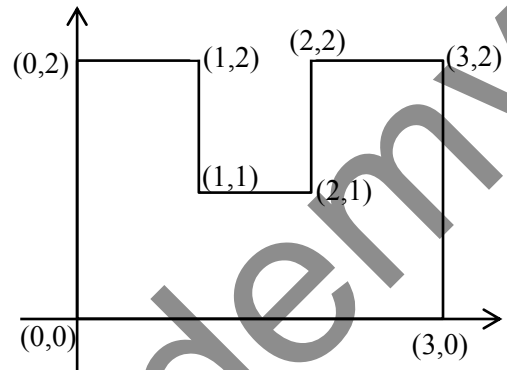

Ans. (15)

Sol. $m_1 = \sigma \times 5 = 10\text{Kg}$

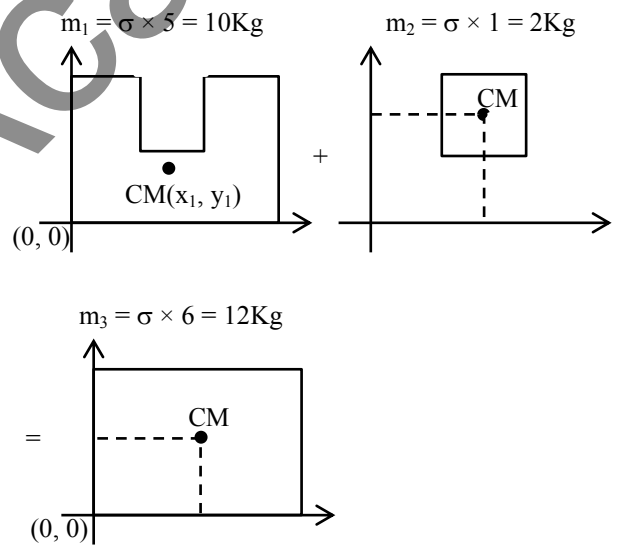

$\Rightarrow m_1 x_1 + m_2 x_2 = m_3 x_3$

$10x_1 + 2(1.5) = 12(1.5) \Rightarrow x_1 = 1.5\text{ cm}$

$\Rightarrow m_1 y_1 + m_2 y_2 = m_3 y_3$

$10y_1 + 2(1.5) = 12 \times 1 \Rightarrow y_1 = 0.9\text{ cm}$

$\frac{x_1}{y_1} = \frac{1.5}{0.9} = \frac{15}{9}$

$n = 15$

52. An electron with kinetic energy 5 eV enters a region of uniform magnetic field of 3 μT perpendicular to its direction. An electric field E is applied perpendicular to the direction of velocity and magnetic field. The value of E , so that electron moves along the same path, is _____ NC^{-1} .

(Given, mass of electron = 9×10^{-31} kg, electric charge = 1.6×10^{-19} C)

Ans. (4)

Sol. For the given condition of moving undeflected, net force should be zero.

$$qE = qvB$$

$$E = vB$$

$$= \sqrt{\frac{2 \times KE}{m}} \times B$$

$$= \sqrt{\frac{2 \times 5 \times 1.6 \times 10^{-19}}{9 \times 10^{-31}}} \times 3 \times 10^{-6}$$

$$= 4 \text{ N/C}$$

53. A square loop PQRS having 10 turns, area $3.6 \times 10^{-3} \text{ m}^2$ and resistance 100 Ω is slowly and uniformly being pulled out of a uniform magnetic field of magnitude $B = 0.5 \text{ T}$ as shown. Work done in pulling the loop out of the field in 1.0 s is _____ $\times 10^{-6} \text{ J}$.

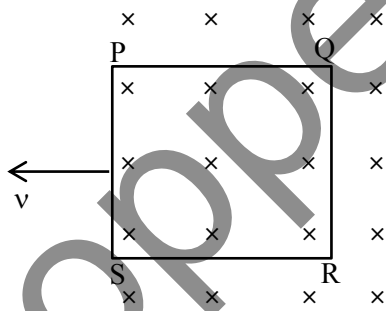

Ans. (3)

Sol. $\epsilon = NB\ell v$

$$i = \frac{\epsilon}{R} = \frac{NB\ell v}{R}$$

$$F = N(i\ell B) = \frac{N^2 B^2 \ell^2 v}{R}$$

$$W = F \times \ell = \frac{N^2 B^2 \ell^3}{R} \left(\frac{\ell}{t} \right)$$

$$A = \ell^2$$

$$W = \frac{(10 \times 10)(0.5)^2 \times (3.6 \times 10^{-3})^2}{100 \times 1}$$

$$W = 3.24 \times 10^{-6} \text{ J}$$

54. Resistance of a wire at 0 $^\circ\text{C}$, 100 $^\circ\text{C}$ and t $^\circ\text{C}$ is found to be 10 Ω , 10.2 Ω and 10.95 Ω respectively. The temperature t in Kelvin scale is _____.

Ans. (748)

Sol. $R = R_0(1 + \alpha\Delta T)$

$$\frac{\Delta R}{R_0} = \alpha\Delta T$$

Case-I

$$0^\circ\text{C} \rightarrow 100^\circ\text{C}$$

$$\frac{10.2 - 10}{10} = \alpha(100 - 0) \quad \dots (1)$$

Case-II

$$0^\circ\text{C} \rightarrow t^\circ\text{C}$$

$$\frac{10.95 - 10}{10} = \alpha(t - 0) \quad \dots (2)$$

$$\Rightarrow \frac{t}{100} = \frac{0.95}{0.2} = 475^\circ\text{C}$$

$$t = 475 + 273 = 748 \text{ K}$$

55. An electric field, $\vec{E} = \frac{2\hat{i} + 6\hat{j} + 8\hat{k}}{\sqrt{6}}$ passes through the surface of 4 m^2 area having unit vector $\hat{n} = \left(\frac{2\hat{i} + \hat{j} + \hat{k}}{\sqrt{6}} \right)$. The electric flux for that surface is _____ V m.

Ans. (12)

Sol. $\phi = \vec{E} \cdot \vec{A}$

$$= \left(\frac{2\hat{i} + 6\hat{j} + 8\hat{k}}{\sqrt{6}} \right) \cdot 4 \left(\frac{2\hat{i} + \hat{j} + \hat{k}}{\sqrt{6}} \right)$$

$$= \frac{4}{6} \times (4 + 6 + 8) = 12 \text{ Vm}$$

56. A liquid column of height 0.04 cm balances excess pressure of soap bubble of certain radius. If density of liquid is $8 \times 10^3 \text{ kg m}^{-3}$ and surface tension of soap solution is 0.28 Nm^{-1} , then diameter of the soap bubble is _____ cm.
(if $g = 10 \text{ ms}^{-2}$)

Ans. (7)

Sol. $\rho gh = \frac{4S}{R}$

$$\Rightarrow R = \frac{4 \times 0.28}{8 \times 10^3 \times 10 \times 4 \times 10^{-4}}$$

$$\Rightarrow \frac{0.28}{8} \text{ m} = \frac{28}{8} \text{ cm}$$

$$\Rightarrow R = 3.5 \text{ cm}$$

$$\text{Diameter} = 7 \text{ cm}$$

57. A closed and an open organ pipe have same lengths. If the ratio of frequencies of their seventh overtones is $\left(\frac{a-1}{a}\right)$ then the value of a is _____.

Ans. (16)

Sol. For closed organ pipe

$$f_c = (2n+1) \frac{v}{4l} = \frac{15v}{4l}$$

For open organ pipe

$$f_o = (n+1) \frac{v}{2l} = \frac{8v}{2l}$$

$$\frac{f_c}{f_o} = \frac{15}{16} = \frac{a-1}{a}$$

$$\Rightarrow a = 16$$

58. Three vectors \vec{OP} , \vec{OQ} and \vec{OR} each of magnitude A are acting as shown in figure. The resultant of the three vectors is $A\sqrt{x}$. The value of x is _____.

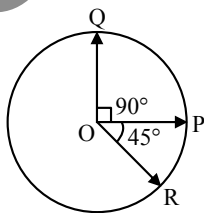

Ans. (3)

Sol.

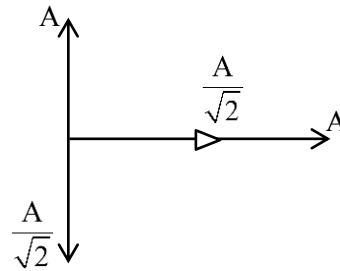

$$\vec{R} = \left(A + \frac{A}{\sqrt{2}}\right)\hat{i} + \left(A - \frac{A}{\sqrt{2}}\right)\hat{j}$$

$$|\vec{R}| = \sqrt{\left(A + \frac{A}{\sqrt{2}}\right)^2 + \left(A - \frac{A}{\sqrt{2}}\right)^2} = \sqrt{3}A$$

59. A parallel beam of monochromatic light of wavelength 600 nm passes through single slit of 0.4 mm width. Angular divergence corresponding to second order minima would be _____ $\times 10^{-3}$ rad.

Ans. (6)

Sol. $\sin \theta = \theta = \frac{2\lambda}{b}$

$$= \frac{2 \times 600 \times 10^{-9}}{4 \times 10^{-4}} = 3 \times 10^{-3} \text{ rad}$$

$$\text{Total divergence} = (3 + 3) \times 10^{-3} = 6 \times 10^{-3} \text{ rad}$$

60. In an alpha particle scattering experiment distance of closest approach for the α particle is $4.5 \times 10^{-14} \text{ m}$. If target nucleus has atomic number 80, then maximum velocity of α -particle is _____ $\times 10^5 \text{ m/s}$ approximately.

$$\left(\frac{1}{4\pi\epsilon_0} = 9 \times 10^9 \text{ SI unit, mass of } \alpha \text{ particle} = \right.$$

$$\left. 6.72 \times 10^{-27} \text{ kg}\right)$$

Ans. (156)

Sol. $v = \sqrt{\frac{4KZe^2}{mr_{\min}}}$

$$= \sqrt{\frac{4 \times 9 \times 10^9 \times 80}{6.72 \times 10^{-27} \times 4.5 \times 10^{-14}}} \times 1.6 \times 10^{-19}$$

$$= 9.759 \times 10^{25} \times 1.6 \times 10^{-19}$$

$$= 156 \times 10^5 \text{ m/s}$$

CHEMISTRY

TEST PAPER WITH SOLUTION

SECTION-A

61. Given below are two statements:

Statement I :

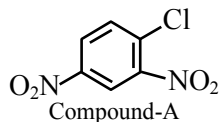

IUPAC name of Compound A is 4-chloro-1,3-dinitrobenzene:

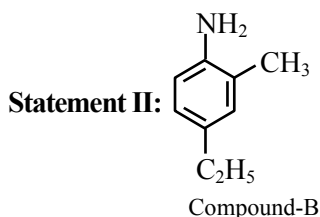

IUPAC name of Compound B is 4-ethyl-2-methylaniline.

In the light of the above statements, choose the **most appropriate** answer from the options given below:

- (1) Both Statement I and Statement II are correct
- (2) Statement I is incorrect but Statement II is correct
- (3) Statement I is correct but Statement II is incorrect
- (4) Both Statement I and Statement II are incorrect

Ans. (2)

Sol. Statement I :

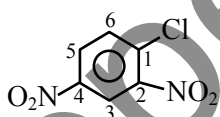

IUPAC name
 \Rightarrow 1-chloro-2,4-dinitrobenzene
 \Rightarrow statement-I is incorrect

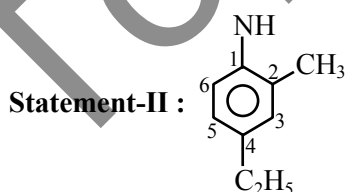

\Rightarrow 4-ethyl-2-methylaniline
 \Rightarrow statement-II is correct

62. Which among the following compounds will undergo fastest S_N2 reaction.

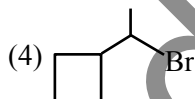
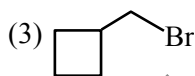
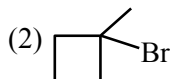
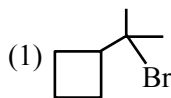

Ans. (3)

Sol.

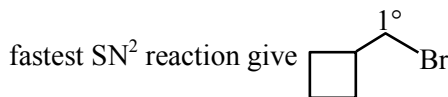
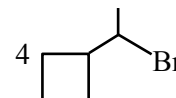

Rate of S_N2 is $Me-x > 1^\circ-x > 2^\circ-x > 3^\circ-x$

63. Combustion of glucose ($C_6H_{12}O_6$) produces CO_2 and water. The amount of oxygen (in g) required for the complete combustion of 900 g of glucose is:

[Molar mass of glucose in $g\ mol^{-1} = 180$]

- (1) 480
- (2) 960
- (3) 800
- (4) 32

Ans. (2)

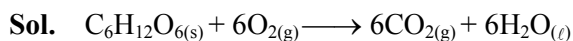

$$\frac{900}{180}$$

$$= 5\ mol \quad 30\ mol$$

$$\text{Mass of } O_2 \text{ required} = 30 \times 32 = 960\ gm$$

64. Identify the major products A and B respectively in the following set of reactions.

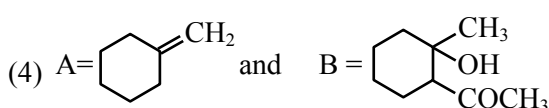
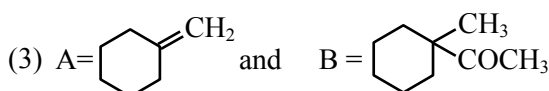
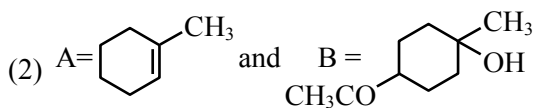
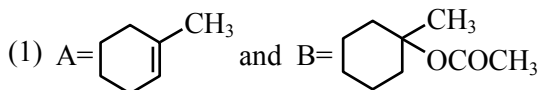
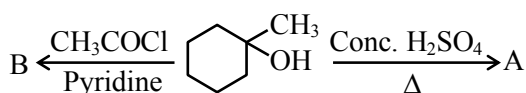

Ans. (1)

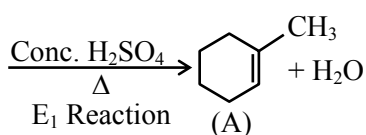
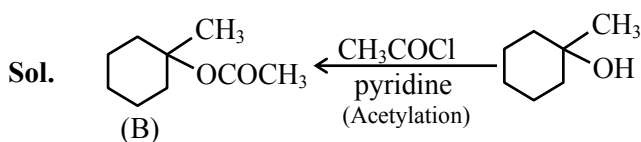

65. Given below are two statements : One is labelled as **Assertion A** and the other is labelled as **Reason R**:

Assertion A : The stability order of +1 oxidation state of Ga, In and Tl is $\text{Ga} < \text{In} < \text{Tl}$.

Reason R : The inert pair effect stabilizes the lower oxidation state down the group.

In the light of the above statements, choose the *correct* answer from the options given below :

- (1) Both **A** and **R** are true and **R** is the correct explanation of **A**.
 (2) **A** is true but **R** is false.
 (3) Both **A** and **R** are true but **R** is NOT the correct explanation of **A**.
 (4) **A** is false but **R** is true.

Ans. (1)

Sol. The relative stability of +1 oxidation state progressively increases for heavier elements due to inert pair effect.

$$\therefore \text{Stability of } Al^{+1} < Ga^{+1} < In^{+1} < Tl^{+1}$$

66. Match List I with List-II

List-I (Name of the test)		List-II (Reaction sequence involved) [M is metal]	
A	Borax bead test	I.	$MCO_3 \rightarrow MO$ $\xrightarrow[+\Delta]{Co(NO_3)_2} CoO \cdot MO$
B.	Charcoal cavity test	II.	$MCO_3 \rightarrow MCl_2 \rightarrow M^{2+}$
C.	Cobalt nitrate test	III.	$MSO_4 \xrightarrow[\Delta]{Na_2B_4O_7} M(BO_2)_2 \rightarrow MBO_2 \rightarrow M$
D.	Flame test	IV.	$MSO_4 \xrightarrow[\Delta]{Na_2CO_3} MCO_3 \rightarrow MO \rightarrow M$

Choose the **correct** answer from the option below :

- (1) A-III, B-I, C-IV, D-II
 (2) A-III, B-II, C-IV, D-I
 (3) A-III, B-I, C-II, D-IV
 (4) A-III, B-IV, C-I, D-II

Ans. (4)

Sol. **Cobalt nitrate test**

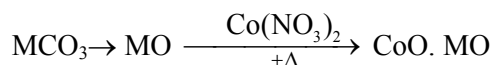

Flame test



Borax Bead test



Charcoal cavity test

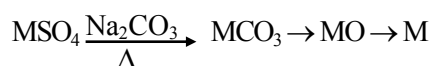

67. Match List I and with List II

List-I (Molecule)		List-II(Shape)	
A	NH ₃	I.	Square pyramid
B.	BrF ₅	II.	Tetrahedral
C.	PCl ₅	III	Trigonal pyramidal
D.	CH ₄	IV	Trigonal bipyramidal

Choose the **correct** answer from the option below :

- (1) A-IV, B-III, C-I, D-II
 (2) A-II, B-IV, C-I, D-III
 (3) A-III, B-I, C-IV, D-II
 (4) A-III, B-IV, C-I, D-II

Ans. (3)

Sol.

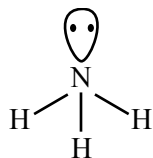

Trigonal pyramidal

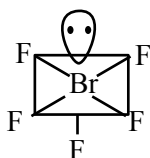

Square pyramidal

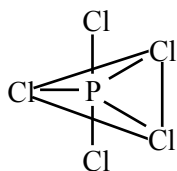

Trigonal bipyramidal

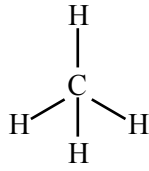

Tetrahedral

68. For the given hypothetical reactions, the equilibrium constants are as follows:

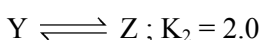
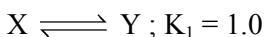

The equilibrium constant for the reaction

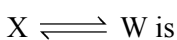

- (1) 6.0 (2) 12.0
 (3) 8.0 (4) 7.0

Ans. (3)

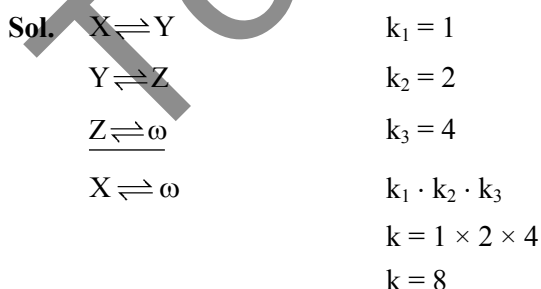

69. Thiosulphate reacts differently with iodine and bromine in the reaction given below :

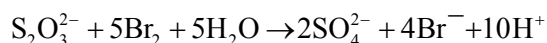
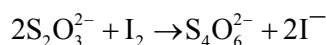

Which of the following statement justifies the above dual behaviour of thiosulphate?

- (1) Bromine undergoes oxidation and iodine undergoes reduction by iodine in these reactions
 (2) Thiosulphate undergoes oxidation by bromine and reduction by iodine in these reaction
 (3) Bromine is a stronger oxidant than iodine
 (4) Bromine is a weaker oxidant than iodine

Ans. (3)

Sol. In the reaction of $S_2O_3^{2-}$ with I_2 , oxidation state of sulphur changes to +2 to +2.5

In the reaction of $S_2O_3^{2-}$ with Br_2 , oxidation state of sulphur changes from +2 to +6.

∴ Both I_2 and Br_2 are oxidant (oxidising agent) and Br_2 is stronger oxidant than I_2 .

70. An octahedral complex with the formula $CoCl_3nNH_3$ upon reaction with excess of $AgNO_3$ solution given 2 moles of $AgCl$. Consider the oxidation state of Co in the complex is 'x'. The value of "x + n" is _____.

- (1) 3 (2) 6
 (3) 8 (4) 5

Ans. (3)

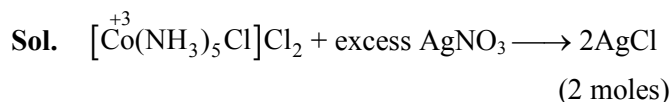

$$x + 0 - 1 - 2 = 0$$

$$x = +3$$

$$n = 5$$

$$\therefore x + n = 8$$

75. Given below are two statements:

Statement I : $\text{N}(\text{CH}_3)_3$ and $\text{P}(\text{CH}_3)_3$ can act as ligands to form transition metal complexes.

Statement II: As N and P are from same group, the nature of bonding of $\text{N}(\text{CH}_3)_3$ and $\text{P}(\text{CH}_3)_3$ is always same with transition metals.

In the light of the above statements, choose the **most appropriate** answer from the options given below:

- (1) Statement I is incorrect but Statement II is correct
- (2) Both Statement I and Statement II are correct
- (3) Statement I is correct but Statement II is incorrect
- (4) Both Statement I and Statement II are incorrect

Ans. (3)

Sol. $\text{N}(\text{CH}_3)_3$ and $\text{P}(\text{CH}_3)_3$ both are Lewis base and acts as ligand, However, $\text{P}(\text{CH}_3)_3$ has a π -acceptor character.

76. Match **List I** with **List II**

List-I (Elements)		List-II (Properties in their respective groups)	
A	Cl, S	I.	Elements with highest electronegativity
B.	Ge, As	II.	Elements with largest atomic size
C.	Fr, Ra	III	Elements which show properties of both metals and non metal
D.	F, O	IV	Elements with highest negative electron gain enthalpy

Choose the **correct** answer from the options given below :

- (1) A-II, B-III, C-IV, D-I
- (2) A-III, B-II, C-I, D-IV
- (3) A-IV, B-III, C-II, D-I
- (4) A-II, B-I, C-IV, D-III

Ans. (3)

Sol. Elements with highest electronegativity \rightarrow F, O

Elements with largest atomic size \rightarrow Fr, Ra

Elements which shows properties of both metal and non-metals i.e. metalloids \rightarrow Ge, As

Elements with highest negative electron gain enthalpy \rightarrow Cl, S

77. Iron (III) catalyses the reaction between iodide and persulphate ions, in which

- A. Fe^{3+} oxidises the iodide ion
- B. Fe^{3+} oxidises the persulphate ion
- C. Fe^{2+} reduces the iodide ion
- D. Fe^{2+} reduces the persulphate ion

Choose the **most appropriate** answer from the options given below:

- (1) B and C only
- (2) B only
- (3) A only
- (4) A and D only

Ans. (4)

Sol. $2\text{Fe}^{3+} + 2\text{I}^- \longrightarrow 2\text{Fe}^{2+} + \text{I}_2$

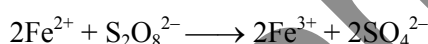

Fe^{3+} oxidises I^- to I_2 and convert itself into Fe^{2+} . This Fe^{2+} reduces $\text{S}_2\text{O}_8^{2-}$ to SO_4^{2-} and converts itself into Fe^{3+} .

78. Match **List I** with **List II**

List-I (Compound)		List-II (Colour)	
A	$\text{Fe}_4[\text{Fe}(\text{CN})_6]_3 \cdot x\text{H}_2\text{O}$	I.	Violet
B.	$[\text{Fe}(\text{CN})_5\text{NOS}]^{4-}$	II.	Blood Red
C.	$[\text{Fe}(\text{SCN})]^{2+}$	III.	Prussian Blue
D.	$(\text{NH}_4)_3\text{PO}_4 \cdot 12\text{MoO}_3$	IV.	Yellow

Choose the **correct** answer from the options given below :

- (1) A-III, B-I, C-II, D-IV
- (2) A-IV, B-I, C-II, D-III
- (3) A-II, B-III, C-IV, D-I
- (4) A-I, B-II, C-III, D-IV

Ans. (1)

Sol. $\text{Fe}_4[\text{Fe}(\text{CN})_6]_3 \cdot x\text{H}_2\text{O} \rightarrow$ Prussian Blue

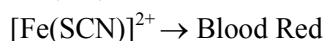

79. Number of complexes with even number of electrons in t_{2g} orbitals is -

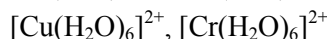
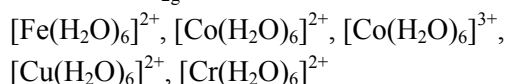

- (1) 1
- (2) 3
- (3) 2
- (4) 5

Ans. (2)

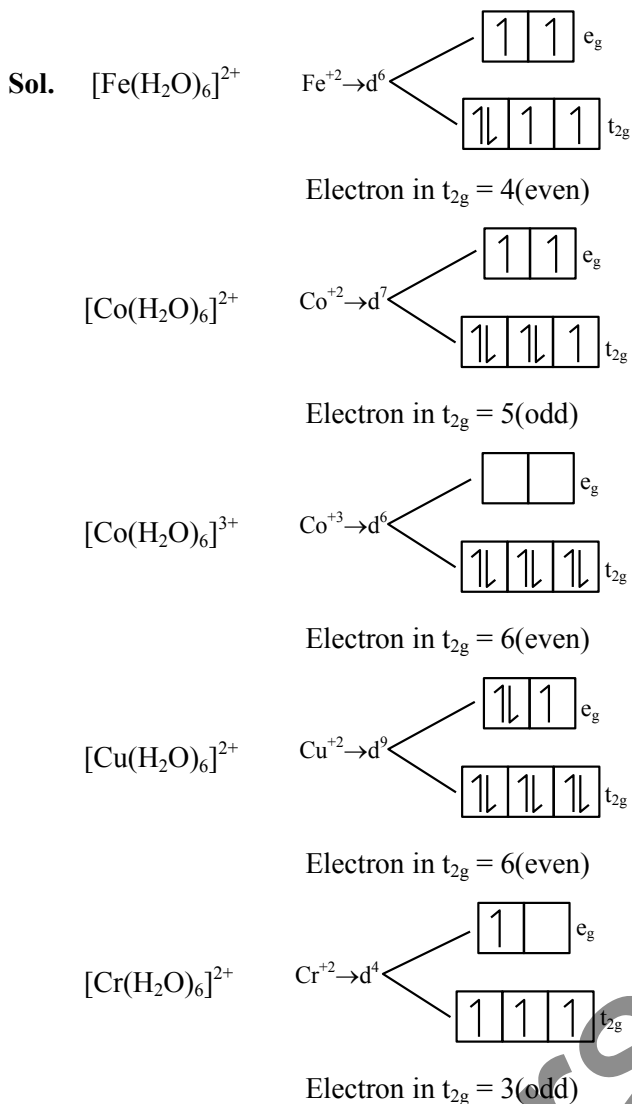

80. Identify the product (P) in the following reaction:

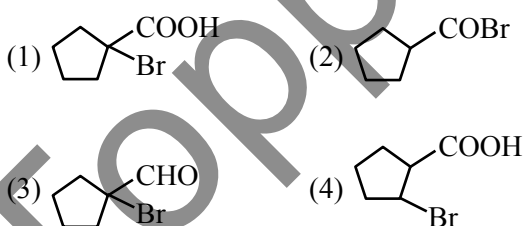
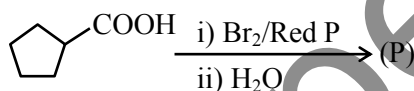

Ans. (1)

Sol. HVZ Reaction

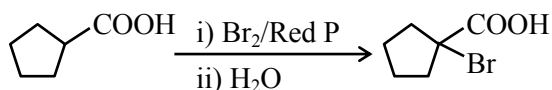

SECTION-B

81. A hypothetical electromagnetic wave is show below.

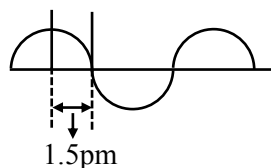

The frequency of the wave is $x \times 10^{19}$ Hz.

$x =$ _____ (nearest integer)

Ans. (5)

Sol. $\lambda = 1.5 \times 4 \text{ pm}$
 $= 6 \times 10^{-12} \text{ meter}$

$\lambda \nu = C$

$6 \times 10^{-12} \times \nu = 3 \times 10^8$

$\nu = 5 \times 10^{19} \text{ Hz}$

82.

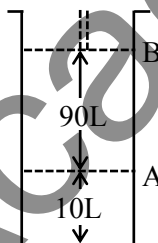

Consider the figure provided.

1 mol of an ideal gas is kept in a cylinder, fitted with a piston, at the position A, at 18°C . If the piston is moved to position B, keeping the temperature unchanged, then 'x' L atm work is done in this reversible process.

$x =$ _____ L atm. (nearest integer)

[Given : Absolute temperature = $^\circ\text{C} + 273.15$,
 $R = 0.08206 \text{ L atm mol}^{-1} \text{ K}^{-1}$]

Ans. (55)

Sol. $\omega = -nRT \ln \left(\frac{V_2}{V_1} \right)$

$= -1 \times 0.08206 \times 291.15 \ln \left(\frac{100}{10} \right)$

$= -55.0128$

Work done by system $\approx 55 \text{ atm lit.}$

83. Number of amine compounds from the following giving solids which are soluble in NaOH upon reaction with Hinsberg's reagent is _____.

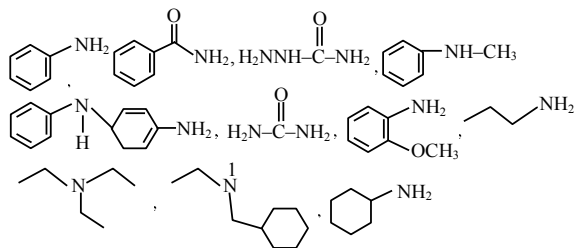

Ans. (5)

Sol. Primary amine give an ionic solid upon reaction with Hinsberg reagent which is soluble in NaOH.

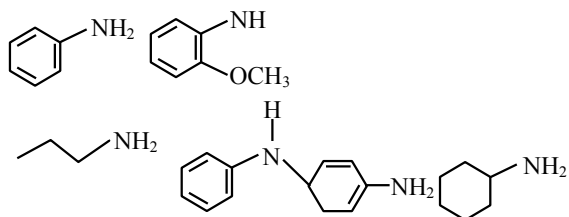

84. The number of optical isomers in following compound is : _____.

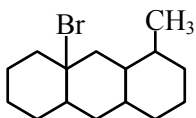

Ans. (32)

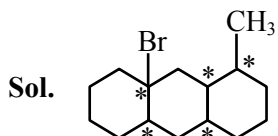

Sol.

Total chiral centre = 5

No. of optical isomers = $2^5 = 32$

85. The 'spin only' magnetic moment value of MO_4^{2-} is _____ BM. (Where M is a metal having least metallic radii. among Sc, Ti, V, Cr, Mn and Zn). (Given atomic number : Sc = 21, Ti = 22, V = 23, Cr = 24, Mn = 25 and Zn = 30)

Ans. (0)

Sol. Metal having least metallic radii among Sc, Ti, V, Cr, Mn & Zn is Cr.

Spin only magnetic moment of CrO_4^{2-} .

Here Cr^{+6} is in d^0 configuration (diamagnetic).

86. Number of molecules from the following which are exceptions to octet rule is _____.
 CO_2 , NO_2 , H_2SO_4 , BF_3 , CH_4 , SiF_4 , ClO_2 , PCl_5 , BeF_2 , C_2H_6 , CHCl_3 , CBr_4

Ans. (6)

Sol.

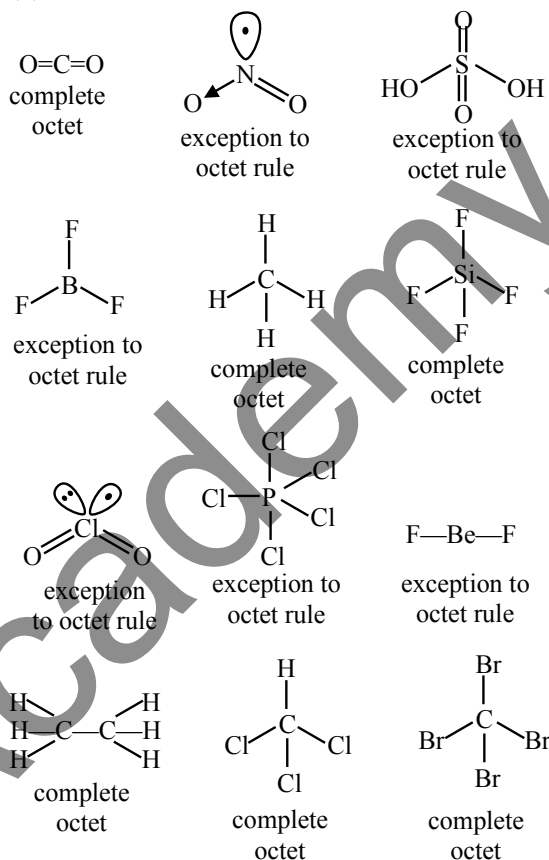

87. If 279 g of aniline is reacted with one equivalent of benzenediazonium chloride, the maximum amount of aniline yellow formed will be _____ g. (nearest integer) (consider complete conversion)

Ans. (591)

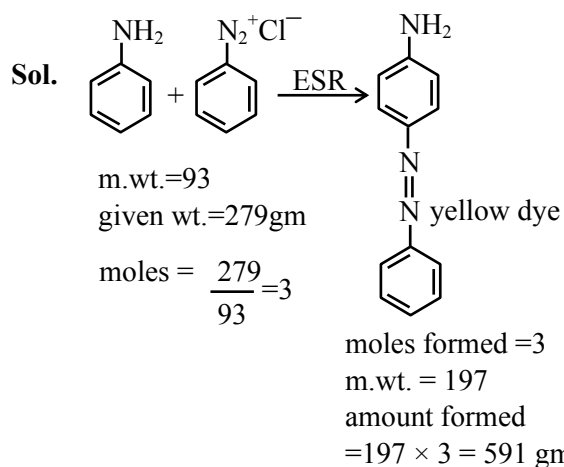

88. Consider the following reaction



The time taken for A to become $1/4^{\text{th}}$ of its initial concentration is twice the time taken to become $1/2$ of the same. Also, when the change of concentration of B is plotted against time, the resulting graph gives a straight line with a negative slope and a positive intercept on the concentration axis.

The overall order of the reaction is ____.

Ans. (1)

Sol. For 1^{st} order reaction

$$75\% \text{ life} = 2 \times 50\% \text{ life}$$

So order with respect to A will be first order.

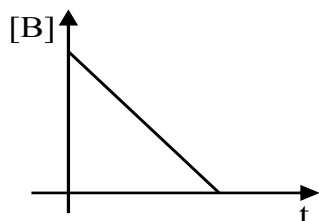

So order with respect to B will be zero.

$$\text{Overall order of reaction} = 1 + 0 = 1$$

89. Major product B of the following reaction has ____ π -bond.

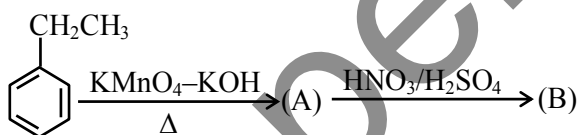

Ans. (5)

Sol. Major product B is \rightarrow

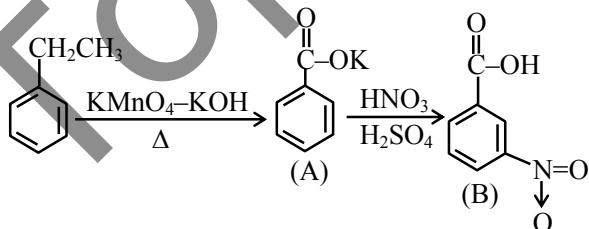

Total number of π bonds in B are 5

90. A solution containing 10g of an electrolyte AB_2 in 100g of water boils at 100.52°C . The degree of ionization of the electrolyte (α) is ____ $\times 10^{-1}$. (nearest integer)

[Given : Molar mass of $AB_2 = 200\text{g mol}^{-1}$. K_b (molal boiling point elevation const. of water) = $0.52\text{ K kg mol}^{-1}$, boiling point of water = 100°C ; AB_2 ionises as $AB_2 \rightarrow A^{2+} + 2B^-$]

Ans. (5)

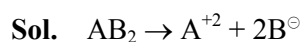

$$i = 1 + (3 - 1)\alpha$$

$$i = 1 + 2\alpha$$

$$\Delta T_b = k_b \cdot i \cdot m$$

$$0.52 = 0.52 (1 + 2\alpha) \frac{10}{\frac{200}{100}} \frac{1000}{1000}$$

$$1 = (1 + 2\alpha) \frac{10}{20}$$

$$2 = 1 + 2\alpha$$

$$\alpha = 0.5$$

$$\text{Ans. } \alpha = 5 \times 10^{-1}$$

4. In an increasing geometric progression of positive terms, the sum of the second and sixth terms is $\frac{70}{3}$ and the product of the third and fifth terms is 3

49. Then the sum of the 4th, 6th and 8th terms is :-

- (1) 96 (2) 78
(3) 91 (4) 84

Ans. (3)

Sol. $T_2 + T_6 = \frac{70}{3}$

$$ar + ar^5 = \frac{70}{3}$$

$$T_3 \cdot T_5 = 49$$

$$ar^2 \cdot ar^4 = 49$$

$$a^2 r^6 = 49$$

$$ar^3 = +7, a = \frac{7}{r^3}$$

$$ar(1 + r^4) = \frac{70}{3}$$

$$\frac{7}{r^2}(1 + r^4) = \frac{70}{3}, r^2 = t$$

$$\frac{1}{t}(1 + t^2) = \frac{10}{3}$$

$$3t^2 - 10t + 3 = 0$$

$$t = 3, \frac{1}{3}$$

Increasing G.P. $r^2 = 3, r = \sqrt{3}$

$$T_4 + T_6 + T_8$$

$$= ar^3 + ar^5 + ar^7$$

$$= ar^3(1 + r^2 + r^4)$$

$$= 7(1 + 3 + 9) = 91$$

5. The number of ways five alphabets can be chosen from the alphabets of the word MATHEMATICS, where the chosen alphabets are not necessarily distinct, is equal to :

- (1) 175 (2) 181
(3) 177 (4) 179

Ans. (4)

Sol. AA, MM, TT, H, I, C, S, E

(1) All distinct

$${}^8C_5 \rightarrow 56$$

(2) 2 same, 3 different

$${}^3C_1 \times {}^7C_3 \rightarrow 105$$

(3) 2 same 1st kind, 2 same 2nd kind, 1 different

$${}^3C_2 \times {}^6C_1 \rightarrow 18$$

$$\text{Total} \rightarrow 179$$

6. The sum of all possible values of $\theta \in [-\pi, 2\pi]$, for which $\frac{1 + i \cos \theta}{1 - 2i \cos \theta}$ is purely imaginary, is equal

to

(1) 2π

(2) 3π

(3) 5π

(4) 4π

Ans. (2)

Sol. $Z = \frac{1 + i \cos \theta}{1 - 2i \cos \theta}$

$$Z = -\bar{Z} \Rightarrow \frac{1 + i \cos \theta}{1 - 2i \cos \theta} = -\left(\frac{1 + i \cos \theta}{1 - 2i \cos \theta}\right)$$

$$(1 + i \cos \theta)(1 - 2i \cos \theta) = -(1 - 2i \cos \theta)(1 + i \cos \theta)$$

$$(1 + i \cos \theta)(1 + 2i \cos \theta) = -(1 - 2i \cos \theta)(1 - i \cos \theta)$$

$$1 + 3i \cos \theta - 2 \cos^2 \theta = -(1 - 3i \cos \theta - 2 \cos^2 \theta)$$

$$2 - 4 \cos^2 \theta = 0$$

$$\Rightarrow \cos^2 \theta = \frac{1}{2} \Rightarrow \theta = -\frac{\pi}{4}, -\frac{3\pi}{4}, \frac{\pi}{4}, \frac{3\pi}{4}, \frac{5\pi}{4}, \frac{7\pi}{4}$$

$$\text{sum} = 3\pi$$

7. If the system of equations $x + 4y - z = \lambda$, $7x + 9y + \mu z = -3$, $5x + y + 2z = -1$ has infinitely many solutions, then $(2\mu + 3\lambda)$ is equal to :

(1) 2

(2) -3

(3) 3

(4) -2

Ans. (2)

Sol. $\Delta = \begin{vmatrix} 1 & 4 & -1 \\ 7 & 9 & \mu \\ 5 & 1 & 2 \end{vmatrix} = 0$

$$\Rightarrow (18 - \mu) - 4(14 - 5\mu) - (7 - 45) = 0 \Rightarrow \mu = 0$$

$$\Delta = \Delta_x = \Delta_y = \Delta_z = 0 \text{ (For infinite solution)}$$

$$\Delta_x = \begin{vmatrix} \lambda & 4 & -1 \\ -3 & 9 & \mu \\ -1 & 1 & 2 \end{vmatrix} = 0$$

$$\lambda(18 - \mu) - 4(-6 + \mu) - 1(-3 + 9) = 0$$

$$18\lambda + 24 - 6 = 0 \Rightarrow \lambda = -1$$

8. If the shortest distance between the lines

$$\frac{x - \lambda}{2} = \frac{y - 4}{3} = \frac{z - 3}{4} \text{ and}$$

$$\frac{x - 2}{4} = \frac{y - 4}{6} = \frac{z - 7}{8} \text{ is } \frac{13}{\sqrt{29}}, \text{ then a value}$$

of λ is :

(1) $-\frac{13}{25}$ (2) $\frac{13}{25}$

(3) 1 (4) -1

Ans. (3)

Sol. $\vec{r}_1 = (\lambda\hat{i} + 4\hat{j} + 3\hat{k}) + \alpha(2\hat{i} + 3\hat{j} + 4\hat{k})$ $\vec{b} = 2\hat{i} + 3\hat{j} + 4\hat{k}$
 $\vec{r}_2 = (2\hat{i} + 4\hat{j} + 7\hat{k}) + \beta(2\hat{i} + 3\hat{j} + 4\hat{k})$ $\vec{a}_1 = \lambda\hat{i} + 4\hat{j} + 3\hat{k}$
 $\vec{a}_2 = 2\hat{i} + 4\hat{j} + 7\hat{k}$

$$\text{Shortest dist.} = \frac{|\vec{b} \times (\vec{a}_2 - \vec{a}_1)|}{|\vec{b}|} = \frac{13}{\sqrt{29}}$$

$$\frac{|(2\hat{i} + 3\hat{j} + 4\hat{k}) \times ((2 - \lambda)\hat{i} + 4\hat{k})|}{\sqrt{29}} = \frac{13}{\sqrt{29}}$$

$$|-8\hat{j} - 3(2 - \lambda)\hat{k} + 12\hat{i} + 4(2 - \lambda)\hat{j}| = 13$$

$$|12\hat{i} - 4\lambda\hat{j} + (3\lambda - 6)\hat{k}| = 13$$

$$144 + 16\lambda^2 + (3\lambda - 6)^2 = 169$$

$$16\lambda^2 + (3\lambda - 6)^2 = 25 = \lambda \Rightarrow = 1$$

9. If the value of $\frac{3 \cos 36^\circ + 5 \sin 18^\circ}{5 \cos 36^\circ - 3 \sin 18^\circ}$ is $\frac{a\sqrt{5} - b}{c}$,

where a, b, c are natural numbers and gcd(a, c) = 1, then a + b + c is equal to :

(1) 50 (2) 40

(3) 52 (4) 54

Ans. (3)

Sol. $\frac{3\left(\frac{\sqrt{5}+1}{4}\right) + 5\left(\frac{\sqrt{5}-1}{4}\right)}{5\left(\frac{\sqrt{5}+1}{4}\right) - 3\left(\frac{\sqrt{5}-1}{4}\right)} = \frac{8\sqrt{5}-2}{2\sqrt{5}+8}$
 $= \frac{4\sqrt{5}-1}{\sqrt{5}+4} \times \frac{\sqrt{5}-4}{\sqrt{5}-4}$

$$= \frac{20 - 16\sqrt{5} - \sqrt{5} + 4}{-11}$$

$$= \frac{17\sqrt{5} - 24}{11} \Rightarrow a = 17, b = 27, c = 11$$

$$a + b + c = 52$$

10. Let $y = y(x)$ be the solution curve of the

$$\text{differential equation } \sec y \frac{dy}{dx} + 2x \sin y = x^3 \cos y,$$

$y(1) = 0$. Then $y(\sqrt{3})$ is equal to :

(1) $\frac{\pi}{3}$

(2) $\frac{\pi}{6}$

(3) $\frac{\pi}{4}$

(4) $\frac{\pi}{12}$

Ans. (3)

Sol. $\sec^2 y \frac{dy}{dx} + 2x \sin y \sec y = x^3 \cos y \sec y$

$$\sec^2 y \frac{dy}{dx} + 2x \tan y = x^3$$

$$\tan y = t \Rightarrow \sec^2 y \frac{dy}{dx} = \frac{dt}{dx}$$

$$\frac{dt}{dx} + 2xt = x^3, \text{ If } t = e^{\int 2x dx} = e^{x^2}$$

$$te^{x^2} = \int x^3 \cdot e^{x^2} dx + c$$

$$x^2 = Z \Rightarrow t \cdot e^Z = \frac{1}{2} \int e^Z \cdot Z dZ = \frac{1}{2} [e^Z \cdot Z - e^Z] + c$$

$$2 \tan y = (x^2 - 1) + 2ce^{-x^2}$$

$$y(1) = 0 \Rightarrow c = 0 \Rightarrow y(\sqrt{3}) = \frac{\pi}{4}$$

11. The area of the region in the first quadrant inside

the circle $x^2 + y^2 = 8$ and outside the parabola $y^2 = 2x$ is equal to :

(1) $\frac{\pi}{2} - \frac{1}{3}$

(2) $\pi - \frac{2}{3}$

(3) $\frac{\pi}{2} - \frac{2}{3}$

(4) $\pi - \frac{1}{3}$

Ans. (2)

Sol.

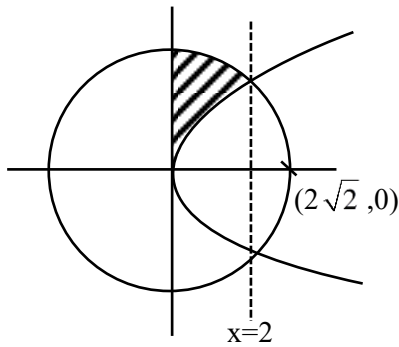

Required area = Ar(circle from 0 to 2) – ar(para from 0 to 2)

$$\begin{aligned}
 &= \int_0^2 \sqrt{8-x^2} \, dx - \int_0^2 \sqrt{2x} \, dx \\
 &= \left[\frac{x}{2} \sqrt{8-x^2} + \frac{8}{2} \sin^{-1} \frac{x}{2\sqrt{2}} \right]_0^2 - \sqrt{2} \left[\frac{2x\sqrt{x}}{3/2} \right]_0^2 \\
 &= \frac{2}{2} \sqrt{8-4} + \frac{8}{2} \sin^{-1} \frac{2}{2\sqrt{2}} - \frac{2\sqrt{2}}{3} (2\sqrt{2} - 0) \\
 &\Rightarrow 2 + 4 \cdot \frac{\pi}{4} - \frac{8}{3} = \pi - \frac{2}{3}
 \end{aligned}$$

12. If the line segment joining the points (5, 2) and (2, a) subtends an angle $\frac{\pi}{4}$ at the origin, then the absolute value of the product of all possible values of a is :

- (1) 6 (2) 8
(3) 2 (4) 4

Ans. (4)

Sol.

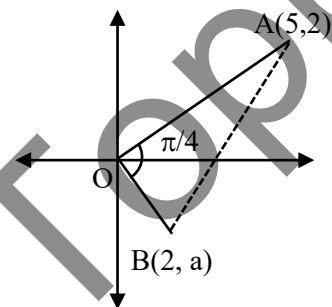

$$m_{OA} = \frac{2}{5}$$

$$m_{OB} = \frac{a}{2}$$

$$\tan \frac{\pi}{4} = \left| \frac{\frac{2}{5} - \frac{a}{2}}{1} \right|$$

$$1 = \left| \frac{4-5a}{10+2a} \right|$$

$$4-5a = \pm(10+2a)$$

$$4-5a = 10+2a$$

$$\Rightarrow 7a+6=0$$

$$\Rightarrow a = -\frac{6}{7}$$

$$-\frac{6}{7} \times \frac{14}{3} = -4$$

$$4-5a = -10-2a$$

$$3a = 14$$

$$a = +\frac{14}{3}$$

13. Let $\vec{a} = 4\hat{i} - \hat{j} + \hat{k}$, $\vec{b} = 11\hat{i} - \hat{j} + \hat{k}$ and \vec{c} be a vector such that

$$(\vec{a} + \vec{b}) \times \vec{c} = \vec{c} \times (-2\vec{a} + 3\vec{b}).$$

If $(2\vec{a} + 3\vec{b}) \cdot \vec{c} = 1670$, then $|\vec{c}|^2$ is equal to :

- (1) 1627 (2) 1618
(3) 1600 (4) 1609

Ans. (2)

Sol. $(\vec{a} + \vec{b}) \times \vec{c} - \vec{c} \times (-2\vec{a} + 3\vec{b}) = 0$

$$(\vec{a} + \vec{b}) \times \vec{c} + (-2\vec{a} + 3\vec{b}) \times \vec{c} = 0$$

$$\Rightarrow (\vec{a} + \vec{b}) - 2\vec{a} + 3\vec{b} \times \vec{c} = 0$$

$$\Rightarrow \vec{c} = \lambda(4\vec{b} - \vec{a})$$

$$\Rightarrow = \lambda(44\hat{i} - 4\hat{j} + 4\hat{k} - 4\hat{i} + \hat{j} - \hat{k})$$

$$= \lambda(40\hat{i} - 3\hat{j} + 3\hat{k})$$

Now

$$(8\hat{i} - 2\hat{j} + 2\hat{k} + 33\hat{i} - 3\hat{j} + 3\hat{k}) \cdot \lambda(40\hat{i} - 3\hat{j} + 3\hat{k}) = 1670$$

$$\Rightarrow (41\hat{i} - 5\hat{j} + 5\hat{k}) \cdot (40\hat{i} - 3\hat{j} + 3\hat{k}) \times \lambda = 1670$$

$$\Rightarrow (1640 + 15 + 15)\lambda = 1670 \Rightarrow \lambda = 1$$

$$\text{so } \vec{c} = 40\hat{i} - 3\hat{j} - 3\hat{k}$$

$$\Rightarrow |\vec{c}|^2 = 1600 + 9 + 9 = 1618$$

14. If the function $f(x) = 2x^3 - 9ax^2 + 12a^2x + 1$, $a > 0$ has a local maximum at $x = \alpha$ and a local minimum $x = \alpha^2$, then α and α^2 are the roots of the equation :

- (1) $x^2 - 6x + 8 = 0$ (2) $8x^2 + 6x - 8 = 0$
 (3) $8x^2 - 6x + 1 = 0$ (4) $x^2 + 6x + 8 = 0$

Ans. (1)

Sol. $f(x) = 6x^2 - 18ax + 12a^2 = 0$ $\begin{cases} \alpha \\ \alpha^2 \end{cases}$

$\alpha + \alpha^2 = 3a$ & $\alpha \times \alpha^2 = 2a^2$

\downarrow
 $(\alpha + \alpha^2)^3 = 27a^3$
 $\Rightarrow 2a^2 + 4a^4 + 3(3a)(2a^2) = 27a^3$
 $\Rightarrow 2 + 4a^2 + 18a = 27a$
 $\Rightarrow 4a^2 - 9a + 2 = 0$
 $\Rightarrow 4a^2 - 8a - a + 2 = 0$
 $\Rightarrow (4a - 1)(a - 2) = 0 \Rightarrow a = 2$
 so $6x^2 - 36x + 48 = 0$
 $\Rightarrow x^2 - 6x + 8 = 0$ (1)

If we take $a = \frac{1}{4}$ then $\alpha = \frac{1}{2}$ which is not possible

15. There are three bags X, Y and Z. Bag X contains 5 one-rupee coins and 4 five-rupee coins; Bag Y contains 4 one-rupee coins and 5 five-rupee coins and Bag Z contains 3 one-rupee coins and 6 five-rupee coins. A bag is selected at random and a coin drawn from it at random is found to be a one-rupee coin. Then the probability, that it came from bag Y, is :

- (1) $\frac{1}{3}$ (2) $\frac{1}{2}$
 (3) $\frac{1}{4}$ (4) $\frac{5}{12}$

Ans. (1)

Sol.

X	Y	Z
5 one & 4 five	4 one & 5 five	3 one & 6 five

$$P = \frac{4/9}{5/9 + 4/9 + 3/9} = \frac{4}{12} = \frac{1}{3}$$

16. Let $\int_{\alpha}^{\log_e 4} \frac{dx}{\sqrt{e^x - 1}} = \frac{\pi}{6}$. Then e^{α} and $e^{-\alpha}$ are the roots of the equation :

- (1) $2x^2 - 5x + 2 = 0$ (2) $x^2 - 2x - 8 = 0$
 (3) $2x^2 - 5x - 2 = 0$ (4) $x^2 + 2x - 8 = 0$

Ans. (1)

Sol. $\int_{\alpha}^{\log_e 4} \frac{dx}{\sqrt{e^x - 1}} = \frac{\pi}{6}$

Let $e^x - 1 = t^2$
 $e^x dx = 2t dt$
 $= \int \frac{2dt}{t^2 + 1}$
 $= 2 \tan^{-1} t$
 $= 2 \tan^{-1} (\sqrt{e^x - 1}) \Big|_{\alpha}^{\log_e 4}$
 $= 2 [\tan^{-1} \sqrt{3} - \tan^{-1} \sqrt{e^{\alpha} - 1}] = \frac{\pi}{6}$

$= \frac{\pi}{3} - \tan^{-1} \sqrt{e^{\alpha} - 1} = \frac{\pi}{12}$

$\Rightarrow \tan^{-1} \sqrt{e^{\alpha} - 1} = \frac{\pi}{4}$

$e^{\alpha} = 2$ $e^{-\alpha} = \frac{1}{2}$

$x^2 - \left(2 + \frac{1}{2}\right)x + 1 = 0$

$2x^2 - 5x + 2 = 0$

17. Let $f(x) = \begin{cases} -a & \text{if } -a \leq x \leq 0 \\ x+a & \text{if } 0 < x \leq a \end{cases}$

where $a > 0$ and $g(x) = (f|x|) - |f(x)|/2$.

Then the function $g : [-a, a] \rightarrow [-a, a]$ is

- (1) neither one-one nor onto.
 (2) both one-one and onto.
 (3) one-one.
 (4) onto

Ans. (1)

Sol. $y = f(x)$

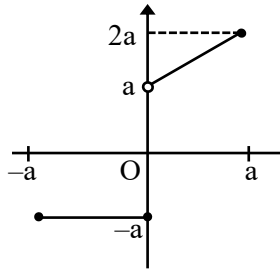

$y = f|x|$

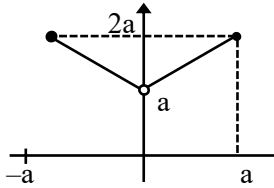

$y = |f(x)|$

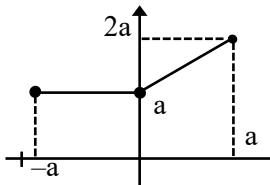

$$g(x) = \frac{f(|x|) - |f(x)|}{2}$$

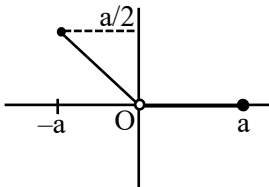

18. Let $A = \{2, 3, 6, 8, 9, 11\}$ and $B = \{1, 4, 5, 10, 15\}$. Let R be a relation on $A \times B$ defined by $(a, b)R(c, d)$ if and only if $3ad - 7bc$ is an even integer. Then the relation R is
- (1) reflexive but not symmetric.
 - (2) transitive but not symmetric.
 - (3) reflexive and symmetric but not transitive.
 - (4) an equivalence relation.

Ans. (3)

Sol. $A = \{2, 3, 6, 8, 9, 11\}$ $(a, b)R(c, d)$
 $B = \{1, 4, 5, 10, 15\}$ $3ad - 7bc$
 Reflexive : $(a, b)R(a, b)$

$\Rightarrow 3ab - 7ba = -4ab$ always even so it is reflexive.

Symmetric : If $3ad - 7bc = \text{Even}$

Case-I : odd odd

Case-II : even even

(c, d) $R(a, b) \Rightarrow 3bc - 3ab$

Case-I : odd odd

Case-II : even even

so symmetric relation

Transitive :

Set $(3, 4)R(6, 4)$ Satisfy relation

Set $(6, 4)R(3, 1)$ Satisfy relation

but $(3, 4)R(3, 1)$ does not satisfy relation

so not transitive.

19. For $a, b > 0$, let

$$f(x) = \begin{cases} \frac{\tan((a+1)x) + b \tan x}{3}, & x < 0 \\ \frac{\sqrt{ax + b^2x^2} - \sqrt{ax}}{b\sqrt{a}x\sqrt{x}}, & x > 0 \end{cases}$$

be a continuous function at $x = 0$. Then $\frac{b}{a}$ is equal

to

- (1) 5
- (2) 4
- (3) 8
- (4) 6

Ans. (4)

Sol. $\lim_{x \rightarrow 0} f(x) = f(0) = 3$

$$\lim_{x \rightarrow 0^+} \frac{\sqrt{ax + b^2x^2} - \sqrt{ax}}{b\sqrt{a}x\sqrt{x}} = 3$$

$$\lim_{x \rightarrow 0^+} \frac{ax + b^2x^2 - ax}{b\sqrt{a}x^{3/2}(\sqrt{ax + b^2x^2} + \sqrt{ax})}$$

$$\lim_{x \rightarrow 0^+} \frac{b^2}{b\sqrt{a}(\sqrt{a + b^2x} + \sqrt{a})}$$

$$\frac{b}{\sqrt{a} \cdot 2\sqrt{a}} \Rightarrow \frac{b}{2a} = 3 \Rightarrow \frac{b}{a} = 6$$

20. If the term independent of x in the expansion of

$$\left(\sqrt{ax^2} + \frac{1}{2x^3}\right)^{10}$$

is 105, then a^2 is equal to :

- (1) 4 (2) 9
 (3) 6 (4) 2

Ans. (1)

Sol. $\left(\sqrt{ax^2} + \frac{1}{2x^3}\right)^{10}$

General term = ${}^{10}C_r (\sqrt{ax^2})^{10-r} \left(\frac{1}{2x^3}\right)^r$

$$20 - 2r - 3r = 0$$

$$r = 4$$

$${}^{10}C_4 a^3 \cdot \frac{1}{16} = 105$$

$$a^3 = 8$$

$$a^2 = 4$$

SECTION-B

21. Let A be the region enclosed by the parabola $y^2 = 2x$ and the line $x = 24$. Then the maximum area of the rectangle inscribed in the region A is _____.

Ans. (128)

Sol.

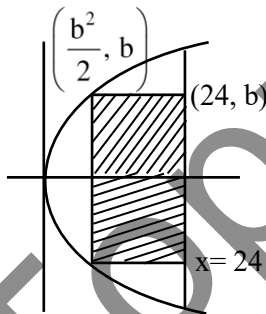

$$A = 2\left(24 - \frac{b^2}{2}\right) \cdot b$$

$$\frac{dA}{db} = 0 \Rightarrow b = 4$$

$$A = 2(24 - 8)4$$

$$= 128$$

22. If $\alpha = \lim_{x \rightarrow 0^+} \left(\frac{e^{\sqrt{\tan x}} - e^{\sqrt{x}}}{\sqrt{\tan x} - \sqrt{x}}\right)$ and

$\beta = \lim_{x \rightarrow 0} (1 + \sin x)^{\frac{1}{2} \cot x}$ are the roots of the quadratic equation $ax^2 + bx - \sqrt{e} = 0$, then $12 \log_e(a + b)$ is equal to _____.

Ans. (6)

Sol. $\alpha = \lim_{x \rightarrow 0^+} e^{\sqrt{x}} \frac{(e^{\sqrt{\tan x} - \sqrt{x}} - 1)}{\sqrt{\tan x} - \sqrt{x}}$

$$= 1$$

$$\beta = \lim_{x \rightarrow 0} (1 + \sin x)^{\frac{1}{2} \cot x}$$

$$= e^{1/2}$$

$$x^2 - (1 + \sqrt{e})x + \sqrt{e} = 0$$

$$ax^2 + bx - \sqrt{e} = 0$$

On comparing

$$a = -1, b = \sqrt{e} + 1$$

$$12 \log_e(a + b) = 12 \times \frac{1}{2} = 6$$

23. Let S be the focus of the hyperbola $\frac{x^2}{3} - \frac{y^2}{5} = 1$,

on the positive x -axis. Let C be the circle with its centre at $A(\sqrt{6}, \sqrt{5})$ and passing through the point S . If O is the origin and SAB is a diameter of C then the square of the area of the triangle OSB is equal to -

Ans. (40)

Sol.

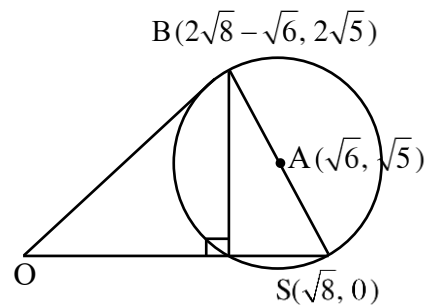

$$\text{Area} = \frac{1}{2} (OS) h = \frac{1}{2} \sqrt{8} \cdot 2\sqrt{5} = \sqrt{40}$$

24. Let $P(\alpha, \beta, \gamma)$ be the image of the point $Q(1, 6, 4)$ in the line $\frac{x}{1} = \frac{y-1}{2} = \frac{z-2}{3}$. Then $2\alpha + \beta + \gamma$ is equal to _____.

Ans. (11)

Sol.

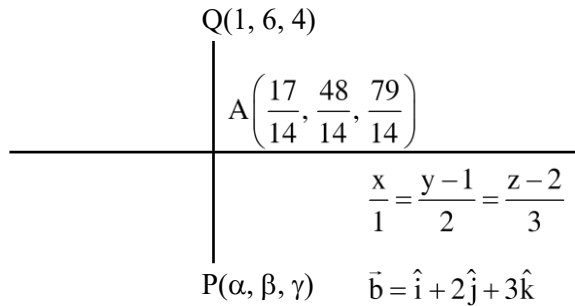

$$A(t, 2t+1, 3t+2)$$

$$\vec{QA} = (t-1)\hat{i} + (2t-5)\hat{j} + (3t-2)\hat{k}$$

$$\vec{QA} \cdot \vec{b} = 0$$

$$(t-1) + 2(2t-5) + 3(3t-2) = 0$$

$$14t = 17$$

$$\alpha = \frac{20}{14} \quad \beta = \frac{12}{14} \quad \gamma = \frac{102}{14}$$

$$2\alpha + \beta + \gamma = \frac{154}{14} = 11$$

25. An arithmetic progression is written in the following way

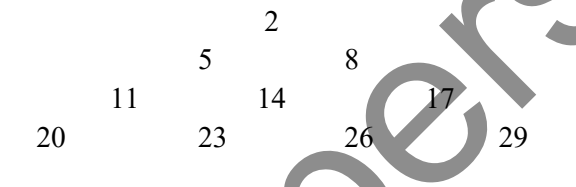

The sum of all the terms of the 10th row is _____.

Ans. (1505)

Sol. 2, 5, 11, 20,

$$\text{General term} = \frac{3n^2 - 3n + 4}{2}$$

$$T_{10} = \frac{3(100) - 3(10) + 4}{2}$$

$$= 137$$

10 terms with c.d. = 3

$$\text{sum} = \frac{10}{2}(2(137) + 9(3))$$

$$= 1505$$

26. The number of distinct real roots of the equation $|x+1||x+3| - 4|x+2| + 5 = 0$, is _____.

Ans. (2)

Sol. $|x+1||x+3| - 4|x+2| + 5 = 0$

case-1

$$x \leq -3$$

$$(x+1)(x+3) + 4(x+2) + 5 = 0$$

$$x^2 + 4x + 3 + 4x + 8 + 5 = 0$$

$$x^2 + 8x + 16 = 0$$

$$(x+4)^2 = 0$$

$$x = -4$$

case-2

$$-3 \leq x \leq -2$$

$$-x^2 - 4x - 3 + 4x + 8 + 5 = 0$$

$$-x^2 + 10 = 0$$

$$x = \pm\sqrt{10}$$

case-3

$$-2 \leq x \leq -1$$

$$-x^2 - 4x - 3 - 4x - 8 + 5 = 0$$

$$-x^2 - 8x - 6 = 0$$

$$x^2 + 8x + 6 = 0$$

$$x = \frac{-8 \pm 2\sqrt{10}}{2} = -4 \pm \sqrt{10}$$

case-4

$$x \geq -1$$

$$x^2 + 4x + 3 - 4x - 8 + 5 = 0$$

$$x^2 = 0$$

$$x = 0$$

No. of solution = 2

27. Let a ray of light passing through the point $(3, 10)$ reflects on the line $2x + y = 6$ and the reflected ray passes through the point $(7, 2)$. If the equation of the incident ray is $ax + by + 1 = 0$, then $a^2 + b^2 + 3ab$ is equal to _____.

Ans. (1)

Sol.

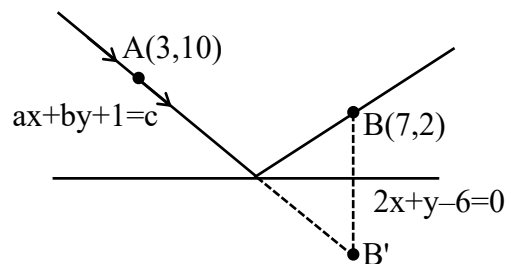

For B' $\frac{x-7}{2} = \frac{y-2}{1} = -2 \left(\frac{14+2-6}{5} \right)$
 $\frac{x-7}{2} = \frac{y-2}{1} = -4$
 $x = -1 \quad y = -2 \quad B'(-1, -2)$

incident ray AB'

$$M_{AB'} = 3$$

$$y + 2 = 3(x + 1)$$

$$3x - y + 1 = 0$$

$$a = 3 \quad b = -1$$

$$a^2 + b^2 + 3ab = 9 + 1 - 9 = 1$$

28. Let $a, b, c \in \mathbb{N}$ and $a < b < c$. Let the mean, the mean deviation about the mean and the variance of the 5 observations 9, 25, a, b, c be 18, 4 and $\frac{136}{5}$, respectively. Then $2a + b - c$ is equal to _____.

Ans. (33)

Sol. $a, b, c \in \mathbb{N} \quad a < b < c$

$$\bar{x} = \text{mean} = \frac{9 + 25 + a + b + c}{5} = 18$$

$$a + b + c = 56$$

$$\text{Mean deviation} = \frac{\sum |x_i - \bar{x}|}{n} = 4$$

$$= 9 + 7 + |18 - a| + |18 - b| + |18 - c| = 20$$

$$= |18 - a| + |18 - b| + |18 - c| = 4$$

$$\text{Variance} = \frac{\sum |x_i - \bar{x}|^2}{n} = \frac{136}{5}$$

$$= 81 + 49 + |18 - a|^2 + |18 - b|^2 + |18 - c|^2 = 136$$

$$= (18 - a)^2 + (18 - b)^2 + (18 - c)^2 = 6$$

Possible values $(18 - a)^2 = 1, (18 - b)^2 = 1, (18 - c)^2 = 4$

$$a < b < c$$

so $18 - a = 1 \quad 18 - b = 1 \quad 18 - c = 2$

$$a = 17 \quad b = 19 \quad c = 20$$

$$a + b + c = 56$$

$$2a + b - c = 34 = 19 - 20 = 33$$

29. Let $\alpha|x| = |y|e^{xy-\beta}$, $\alpha, \beta \in \mathbb{N}$ be the solution of the differential equation $xdy - ydx + xy(xdy + ydx) = 0$, $y(1) = 2$. Then $\alpha + \beta$ is equal to _____

Ans. (4)

Sol. $\alpha|x| = |y|e^{xy-\beta}$, $a, b \in \mathbb{N}$
 $xdy - ydx + xy(xdy + ydx) = 0$

$$\frac{dy}{y} - \frac{dx}{x} + (xdy + ydx) = 0$$

$$\ln|y| - \ln|x| + xy = c$$

$$y(1) = 2$$

$$\ln|2| - 0 + 2 = c$$

$$c = 2 + \ln 2$$

$$\ln|y| - \ln|x| + xy = 2 + \ln 2$$

$$\ln|x| = \ln\left|\frac{y}{2}\right| - 2 + xy$$

$$|x| = \left|\frac{y}{2}\right|e^{xy-2}$$

$$2|x| = |y|e^{xy-2}$$

$$\alpha = 2 \quad \beta = 2 \quad \alpha + \beta = 4$$

30. If $\int \frac{1}{\sqrt[5]{(x-1)^4(x+3)^6}} dx = A \left(\frac{\alpha x - 1}{\beta x + 3} \right)^B + C$,

where C is the constant of integration, then the value of $\alpha + \beta + 20AB$ is _____.

Ans. (7)

Sol. $\int \frac{1}{\sqrt[5]{(x-1)^4(x+3)^6}} dx = A \left(\frac{\alpha x - 1}{\beta x + 3} \right)^B + C$

$$I = \int \frac{1}{(x-1)^{4/5}(x+3)^{6/5}} dx$$

$$I = \int \frac{1}{\left(\frac{x-1}{x+3}\right)^{4/5}(x+3)^2} dx$$

$$\left(\frac{x-1}{x+3}\right) = t \Rightarrow \frac{4}{(x+3)^2} dx = dt \quad t^{-4/5+1}$$

$$I = \frac{1}{4} \int \frac{1}{t^{4/5}} dt = \frac{1}{4} \frac{t^{1/5}}{1/5} + c$$

$$I = \frac{5}{4} \left(\frac{x-1}{x+3} \right)^{1/5} + C$$

$$A = \frac{5}{4} \quad \alpha = \beta = 1 \quad B = \frac{1}{5}$$

$$\alpha + \beta + 20AB = 2 + 20 \times \frac{5}{4} \times \frac{1}{5} = 7$$

PHYSICS

TEST PAPER WITH SOLUTION

SECTION-A

31.

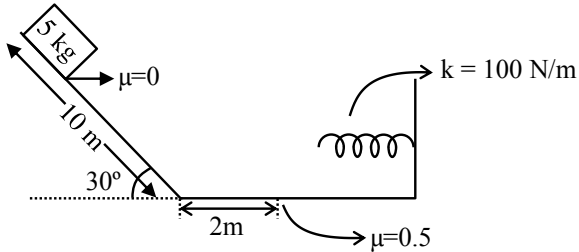

A block is simply released from the top of an inclined plane as shown in the figure above. The maximum compression in the spring when the block hits the spring is :

- (1) $\sqrt{6}m$ (2) 2 m
 (3) 1 m (4) $\sqrt{5}m$

Ans. (2)

Sol. $w_g + w_{Fr} + w_s = \Delta KE$

$$5 \times 10 \times 5 - 0.5 \times 5 \times 10 \times x - \frac{1}{2} Kx^2 = 0 - 0$$

$$250 = 25x + 50x^2$$

$$2x^2 + x - 10 = 0$$

$$x = 2$$

32. In a hypothetical fission reaction

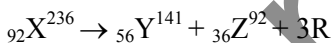

The identity of emitted particles (R) is :

- (1) Proton (2) Electron
 (3) Neutron (4) γ -radiations

Ans. (3)

Sol. Z in LHS = 92

$$Z \text{ in RHS} = 56 + 36 = 92$$

$$A \text{ in LHS} = 236$$

$$A \text{ in RHS} = 141 + 92 = 233$$

So 3 neutrons are released.

33. If ϵ_0 is the permittivity of free space and E is the electric field, then $\epsilon_0 E^2$ has the dimensions :

- (1) $[M^0 L^{-2} T A]$ (2) $[M L^{-1} T^{-2}]$
 (3) $[M^{-1} L^{-3} T^4 A^2]$ (4) $[M L^2 T^{-2}]$

Ans. (2)

Sol. $E = \frac{KQ}{R^2}$

$$E = \frac{Q}{4\pi\epsilon_0 R^2}$$

$$\epsilon_0 = \frac{Q}{4\pi R^2 E}$$

$$\text{Now, } \epsilon_0 E^2 = \frac{Q}{4\pi R^2 E} \cdot E^2 = \frac{Q}{4\pi R^2} \cdot E$$

$$[\epsilon_0 E^2] = \left[\frac{[Q][E]}{[R^2]} \right] = \frac{[Q][E]}{[R^2]} = \frac{[Q]}{[R^2]} \frac{[W]}{[Q][R]}$$

$$= \frac{[W]}{[R^3]} = \frac{ML^2T^{-2}}{L^3} = ML^{-1}T^{-2}$$

34. The position of the image formed by the combination of lenses is :

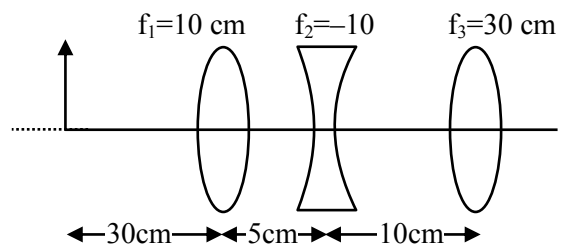

- (1) 30 cm (right of third lens)
 (2) 15 cm (left of second lens)
 (3) 30 cm (left of third lens)
 (4) 15 cm (right of second lens)

Ans. (1)

Sol. For lens 1 : $f_1 = 10, u = -30, v = ?$

$$v = \frac{uf}{u+f} = \frac{-30 \times 10}{-30+10} = 15$$

For lens 2 : $f_1 = -10, u = 10, v = ?$

$$v = \frac{uf}{u+f} = \frac{10 \times -10}{10-10} = \infty$$

For lens 3 : $f = 30, u = -\infty, v = ?$

So v will be 30.

35. A plane progressive wave is given by $y = 2 \cos 2\pi(330 t - x)$ m. The frequency of the wave is :

- (1) 165 Hz (2) 330 Hz
(3) 660 Hz (4) 340 Hz

Ans. (2)

Sol. $y = 2 \cos 2\pi(330 t - x)$ m

$$y = A \cos(\omega t - kx)$$

by comparing $\omega = 2\pi \times 330$

$$2\pi f = 2\pi \times 330$$

$$f = 330$$

36. A thin circular disc of mass M and radius R is rotating in a horizontal plane about an axis passing through its centre and perpendicular to its plane with angular velocity ω . If another disc of same dimensions but of mass $\frac{M}{2}$ is placed gently on the first disc co-axially, then the new angular velocity of the system is :

- (1) $\frac{4}{5}\omega$ (2) $\frac{5}{4}\omega$
(3) $\frac{2}{3}\omega$ (4) $\frac{3}{2}\omega$

Ans. (3)

Sol. $I_1\omega = I_2\omega_2$

$$\frac{MR^2}{2}\omega = \frac{3}{2}\left(\frac{MR^2}{2}\right)\omega_2$$

$$\omega_2 = \frac{2}{3}\omega$$

37. A cube of ice floats partly in water and partly in kerosene oil. The ratio of volume of ice immersed in water to that in kerosene oil (specific gravity of Kerosene oil = 0.8, specific gravity of ice = 0.9)

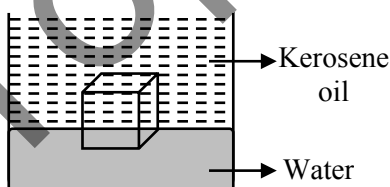

- (1) 8 : 9 (2) 5 : 4
(3) 9 : 10 (4) 1 : 1

Ans. (4)

Sol. v_1 = volume immersed in water.

v_2 = volume immersed in oil.

$$v_1 \rho_w g + v_2 \rho_o g = (v_1 + v_2) \rho_c g$$

$$v_1 + \frac{v_2 \rho_o}{\rho_w} = (v_1 + v_2) \frac{\rho_c}{\rho_w}$$

$$= v_1 + 0.8 v_2 = 0.9 v_1 + 0.9 v_2$$

$$= 0.1 v_1 = 0.1 v_2$$

$$v_1 : v_2 = 1 : 1$$

38. Given below are two statements :

Statement (I) : The mean free path of gas molecules is inversely proportional to square of molecular diameter.

Statement (II) : Average kinetic energy of gas molecules is directly proportional to absolute temperature of gas.

In the light of the above statements, choose the correct answer from the option given below:

- (1) **Statement I** is false but **Statement II** is true.
(2) **Statement I** is true but **Statement II** is false.
(3) Both **Statement I** and **Statement II** are false
(4) Both **Statement I** and **Statement II** are true.

Ans. (4)

Sol. $\lambda = \frac{RT}{\sqrt{2}\pi d^2 N_A P}$

$$KE = \frac{f}{2} nRT$$

39. Two satellite A and B go round a planet in circular orbits having radii $4R$ and R respectively. If the speed of A is $3v$, the speed of B will be :

- (1) $\frac{4}{3}v$ (2) $3v$
(3) $6v$ (4) $12v$

Ans. (3)

Sol. $v = \sqrt{\frac{GM}{R}}$

$$\frac{v_A}{v_B} = \sqrt{\frac{R_B}{R_A}} = \sqrt{\frac{R}{4R}} = \frac{1}{2}$$

$$v_B = 2v_A = 6v$$

Case-2 : With friction

$$a = g \sin \theta - \mu g \cos \theta$$

$$\ell = \frac{1}{2}(g \sin \theta - \mu g \cos \theta)t_2^2$$

$$\sqrt{\frac{2\ell}{g \sin \theta - \mu g \cos \theta}} = n \sqrt{\frac{2\ell}{g \sin \theta}}$$

$$\mu = 1 - \frac{1}{n^2}$$

45. A coil of negligible resistance is connected in series with 90Ω resistor across 120 V , 60 Hz supply. A voltmeter reads 36 V across resistance.

Inductance of the coil is :

- (1) 0.76 H (2) 2.86 H
 (3) 0.286 H (4) 0.91 H

Ans. (1)

Sol.

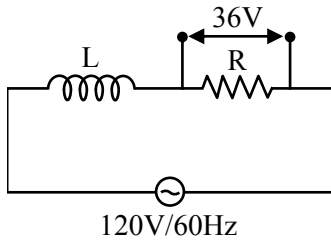

$$36 = I_{\text{rms}} R$$

$$36 = \frac{120}{\sqrt{X_L^2 + R^2}} \times R$$

$$R = 90 \Omega \Rightarrow 36 = \frac{120 \times 90}{\sqrt{X_L^2 + 90^2}}$$

$$\sqrt{X_L^2 + 90^2} = 300$$

$$X_L^2 = 81900$$

$$X_L = 286.18$$

$$\omega L = 286.18$$

$$L = \frac{286.18}{376.8}$$

$$L = 0.76 \text{ H}$$

46. There are 100 divisions on the circular scale of a screw gauge of pitch 1 mm . With no measuring quantity in between the jaws, the zero of the circular scale lies 5 divisions below the reference line. The diameter of a wire is then measured using this screw gauge. It is found the 4 linear scale divisions are clearly visible while 60 divisions on circular scale coincide with the reference line. The diameter of the wire is :

- (1) 4.65 mm (2) 4.55 mm
 (3) 4.60 mm (4) 3.35 mm

Ans. (2)

$$\text{Sol. Least count} = \frac{1}{100} \text{ mm} = 0.01 \text{ mm}$$

$$\text{zero error} = +0.05 \text{ mm}$$

$$\text{Reading} = 4 \times 1 \text{ mm} + 60 \times 0.01 \text{ mm} - 0.05 \text{ mm} = 4.55 \text{ mm}$$

47. A proton and an electron have the same de Broglie wavelength. If K_p and K_e be the kinetic energies of proton and electron respectively. Then choose the correct relation :

- (1) $K_p > K_e$ (2) $K_p = K_e$
 (3) $K_p = K_e^2$ (4) $K_p < K_e$

Ans. (4)

Sol. De Broglie wavelength of proton & electron = λ

$$\therefore \lambda = \frac{h}{p}$$

$$\therefore p_{\text{proton}} = p_{\text{electron}}$$

$$\therefore KE = \frac{p^2}{2m}$$

$$\therefore KE_{\text{proton}} < KE_{\text{electron}}$$

$$[K_p < K_e]$$

48. Least count of a vernier caliper is $\frac{1}{20N} \text{ cm}$. The value of one division on the main scale is 1 mm . Then the number of divisions of main scale that coincide with N divisions of vernier scale is :

- (1) $\left(\frac{2N-1}{20N}\right)$ (2) $\left(\frac{2N-1}{2}\right)$
 (3) $(2N-1)$ (4) $\left(\frac{2N-1}{2N}\right)$

Ans. (2)

Sol. Least count of vernier calipers = $\frac{1}{20N}$ cm

\therefore Least count = 1 MSD – 1 VSD

let x no. of divisions of main scale coincides with N division of vernier scale, then

$$1 \text{ VSD} = \frac{x \times 1\text{mm}}{N}$$

$$\therefore \frac{1}{20N} \text{ cm} = 1 \text{ mm} - \frac{x \times 1\text{mm}}{N}$$

$$\frac{1}{2N} \text{ mm} = 1\text{mm} - \frac{x}{N} \text{ mm}$$

$$x = \left(1 - \frac{1}{2N}\right) N$$

$$x = \frac{2N - 1}{2}$$

49. If M_o is the mass of isotope ${}^{12}_5\text{B}$, M_p and M_n are the masses of proton and neutron, then nuclear binding energy of isotope is :

(1) $(5 M_p + 7 M_n - M_o)C^2$

(2) $(M_o - 5 M_p)C^2$

(3) $(M_o - 12 M_n)C^2$

(4) $(M_o - 5 M_p - 7 M_n)C^2$

Ans. (1)

Sol. B.E. = $\Delta m C^2$

$$(5 M_p + 7 M_n - M_o)C^2$$

50. A diatomic gas ($\gamma = 1.4$) does 100 J of work in an isobaric expansion. The heat given to the gas is :

(1) 350 J

(2) 490 J

(3) 150 J

(4) 250 J

Ans. (1)

For Isobaric process

$$w = P\Delta v = nR\Delta T = 100 \text{ J}$$

$$Q = \Delta u + w$$

$$\Delta Q = \frac{f}{2} nR\Delta T + nR\Delta T$$

$$\left(\frac{f}{2} + 1\right) nR\Delta T$$

$$\left(\frac{5}{2} + 1\right) 100 = 350 \text{ J}$$

SECTION-B

51. The coercivity of a magnet is 5×10^3 A/m. The amount of current required to be passed in a solenoid of length 30 cm and the number of turns 150, so that the magnet gets demagnetised when inside the solenoid isA.

Ans. (10)

Sol.

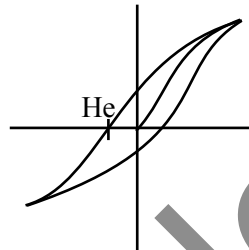

$$H_c = \frac{\mu_o ni}{\mu_o}$$

$$5 \times 10^3 = \frac{150}{30} \times 100 \times i$$

$$\frac{50}{5} = i$$

$$I = 10$$

52. Small water droplets of radius 0.01 mm are formed in the upper atmosphere and falling with a terminal velocity of 10 cm/s. Due to condensation, if 8 such droplets are coalesced and formed a larger drop, the new terminal velocity will becm/s.

Ans. (40)

Sol. m = mass of small drop

M = mass of bigger drop

$$V_t = \frac{2 R^2 (\rho - \sigma) g}{9 \eta}$$

$$8 \propto m = M$$

$$8r^3 = R^3 \Rightarrow R = 2R$$

as $V_t \propto R^2 \therefore$ Radius double so V_t becomes 4 time

$$\therefore 4 \times 10 = 40 \text{ cm/s}$$

53. If the net electric field at point P along Y axis is zero, then the ratio of $\left| \frac{q_2}{q_3} \right|$ is $\frac{8}{5\sqrt{x}}$,

where $x = \dots\dots\dots$

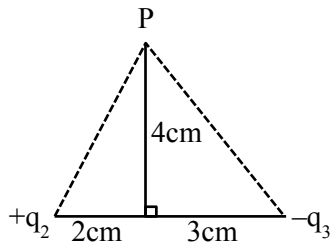

Ans. (5)

Sol.

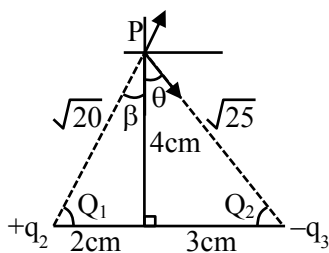

$$\frac{Kq_2}{20} \cos\beta = \frac{Kq_3}{25} \cos\theta$$

$$\frac{Kq_2}{20} \frac{4}{\sqrt{20}} = \frac{Kq_3}{25} \frac{4}{\sqrt{25}}$$

$$\frac{q_2}{q_3} = \frac{20}{25} \sqrt{\frac{20}{25}} = \frac{8}{5\sqrt{x}}$$

$$\Rightarrow \sqrt{x} = \frac{8 \times 25 \sqrt{25}}{5 \times 20 \sqrt{20}}$$

$$x = 5$$

54. A heater is designed to operate with a power of 1000 W in a 100 V line. It is connected in combination with a resistance of 10 Ω and a resistance R, to a 100 V mains as shown in figure. For the heater to operate at 62.5 W, the value of R should be $\dots\dots\dots \Omega$.

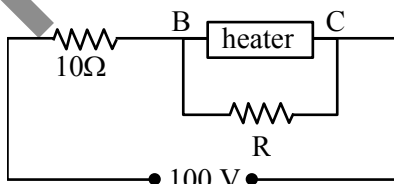

Ans. (5)

$$\text{Sol. } R_{\text{heater}} = \frac{V^2}{P} = \frac{(100)^2}{1000} = 10\Omega$$

$$\text{For heater } P = \frac{V^2}{R} \Rightarrow V = \sqrt{PR}$$

$$V = \sqrt{62.5 \times 10}$$

$$V = 25 \text{ v}$$

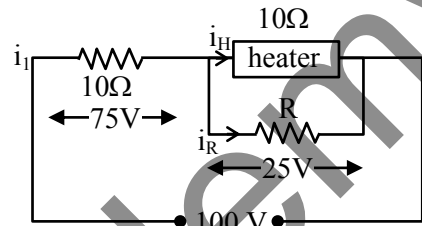

$$i_1 = \frac{75}{10} = 7.5 \text{ A}, \quad i_H = \frac{25}{10} = 2.5 \text{ A.}$$

$$i_R = i_1 - i_H = 5$$

$$V = IR$$

$$R = \frac{25}{5} = 5\Omega$$

55. An alternating emf $E = 110\sqrt{2} \sin 100t$ volt is applied to a capacitor of $2\mu\text{F}$, the rms value of current in the circuit is $\dots\dots\dots \text{mA}$.

Ans. (22)

$$\text{Sol. } C = 2\mu\text{f}; \quad E = 110\sqrt{2} \sin(100t)$$

$$X_C = \frac{1}{\omega C} = \frac{1}{100 \times 2 \times 10^6}$$

$$= \frac{10000}{2} = 5000\Omega$$

$$i_o = \frac{110\sqrt{2}}{5000}$$

$$i_{\text{rms}} = \frac{110\sqrt{2}}{5000\sqrt{2}}$$

$$= \frac{110}{5} \text{ mA}$$

$$= 22 \text{ mA}$$

56. Two slits are 1 mm apart and the screen is located 1 m away from the slits. A light wavelength 500 nm is used. The width of each slit to obtain 10 maxima of the double slit pattern within the central maximum of the single slit pattern is $\times 10^{-4}$ m.

Ans. (2)

Sol. $d = 1 \text{ mm}$, $D = 1 \text{ m}$, $\lambda = 500 \text{ nm}$

$$10 \left(\frac{\lambda D}{d} \right) = \frac{2\lambda D}{a}$$

$$a = \frac{d}{5}$$

$$= \frac{10 \times 10^{-4} \text{ m}}{5}$$

$$= 2 \times 10^{-4}$$

57. An object of mass 0.2 kg executes simple harmonic motion along x axis with frequency of $\left(\frac{25}{\pi} \right)$ Hz. At the position $x = 0.04 \text{ m}$ the object has kinetic energy 0.5 J and potential energy 0.4 J. The amplitude of oscillation is cm.

Ans. (6)

Sol. Total energy = K.E. + P.E.

$$\text{at } x = 0.04 \text{ m, T.E.} = 0.5 + 0.4 = 0.9 \text{ J}$$

$$\text{T.E.} = 1 m \omega^2 A^2 = 0.9$$

$$= \frac{1}{2} \times 0.2 \left(2\pi \times \frac{25}{\pi} \right)^2 \times A^2 = 0.9$$

$$\Rightarrow A = 0.06 \text{ m}$$

$$A = 6 \text{ cm}$$

58. A potential divider circuit is connected with a dc source of 20 V, a light emitting diode of glow in voltage 1.8 V and a zener diode of breakdown voltage of 3.2 V. The length (PR) of the resistive wire is 20 cm. The minimum length of PQ to just glow the LED is cm.

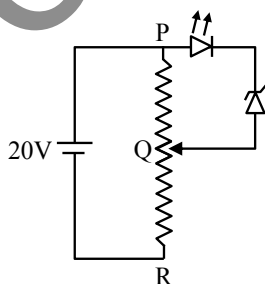

Ans. (5)

Sol.

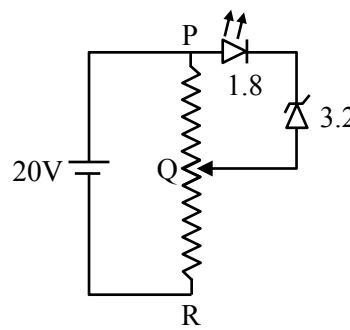

$$PR = 20 \text{ cm}$$

$$V_{PQ} = \frac{1}{4} \times R_{PR}$$

$$l_{\min} (PQ) = \frac{1}{4} \times 20$$

$$= 5 \text{ cm}$$

59. A body of mass M thrown horizontally with velocity v from the top of the tower of height H touches the ground at a distance of 100m from the foot of the tower. A body of mass $2M$ thrown at a velocity $\frac{v}{2}$ from the top of the tower of height $4H$ will touch the ground at a distance ofm.

Ans. (100)

Sol.

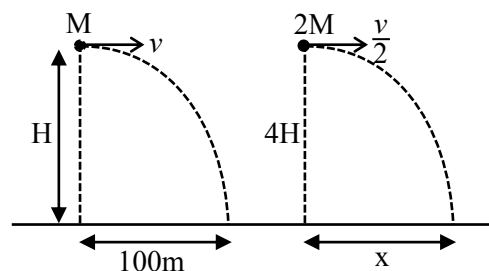

$$100 = v \sqrt{\frac{2H}{g}}; \quad x = \frac{v}{2} \sqrt{\frac{2(4H)}{g}} = v \sqrt{\frac{2H}{g}}$$

$$\Rightarrow x = 100$$

60. A circular table is rotating with an angular velocity of ω rad/s about its axis (see figure). There is a smooth groove along a radial direction on the table. A steel ball is gently placed at a distance of 1m on the groove. All the surface are smooth. If the radius of the table is 3 m, the radial velocity of the ball w.r.t. the table at the time ball leaves the table is $x\sqrt{2}\omega$ m/s, where the value of x is.....

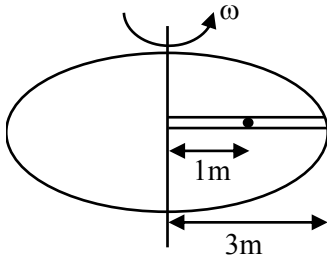

Ans. (2)

Sol. $a_c = \omega^2 x$

$$\frac{v dv}{dx} = \omega^2 x$$

$$\int_0^v v dv = \int_1^3 \omega^2 x dx$$

$$\frac{v^2}{2} = \omega^2 \left[\frac{x^2}{2} \right]$$

$$\frac{v^2}{2} = \frac{\omega^2}{2} [3^2 - 1^2]$$

$$v = 2\sqrt{2}\omega$$

$$x = 2$$

CHEMISTRY

SECTION-A

61. In qualitative test for identification of presence of phosphorous, the compound is heated with an oxidising agent. Which is further treated with nitric acid and ammonium molybdate respectively. The yellow coloured precipitate obtained is :

- (1) $\text{Na}_3\text{PO}_4 \cdot 12\text{MoO}_3$
 (2) $(\text{NH}_4)_3\text{PO}_4 \cdot 12(\text{NH}_4)_2\text{MoO}_4$
 (3) $(\text{NH}_4)_3\text{PO}_4 \cdot 12\text{MoO}_3$
 (4) $\text{MoPO}_4 \cdot 21\text{NH}_4\text{NO}_3$

Ans. (3)

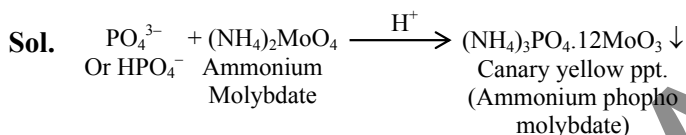

62. For a reaction $A \xrightarrow{K_1} B \xrightarrow{K_2} C$

If the rate of formation of B is set to be zero then the concentration of B is given by :

- (1) $K_1K_2[A]$ (2) $(K_1 - K_2)[A]$
 (3) $(K_1 + K_2)[A]$ (4) $(K_1/K_2)[A]$

Ans. (4)

Sol. Rate of formation of B is

$$\frac{d[B]}{dt} = k_1[A] - k_2[B]$$

$$0 = k_1[A] - k_2[B]$$

$$\left(\frac{k_1}{k_2}\right)[A] = [B]$$

63. When ψ_A and ψ_B are the wave functions of atomic orbitals, then σ^* is represented by :

- (1) $\psi_A - 2\psi_B$ (2) $\psi_A - \psi_B$
 (3) $\psi_A + 2\psi_B$ (4) $\psi_A + \psi_B$

Ans. (2)

TEST PAPER WITH SOLUTION

Sol. Antibonding molecular orbitals are formed by destructive interference of wave functions.

$$(\text{ABMO}) \sigma^* = \psi_A - \psi_B$$

64. Which one the following compounds will readily react with dilute NaOH?

- (1) $\text{C}_6\text{H}_5\text{CH}_2\text{OH}$ (2) $\text{C}_2\text{H}_5\text{OH}$
 (3) $(\text{CH}_3)_3\text{COH}$ (4) $\text{C}_6\text{H}_5\text{OH}$

Ans. (4)

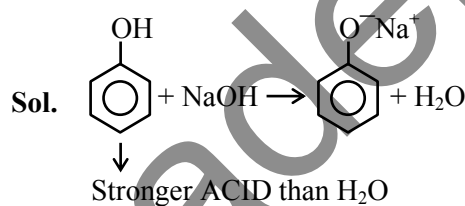

65. The shape of carbocation is :

- (1) trigonal planar (2) diagonal pyramidal
 (3) tetrahedral (4) diagonal

Ans. (1)

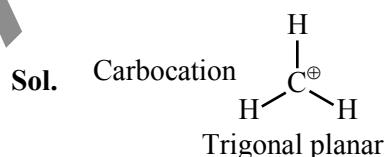

66. Given below are two statements :

Statement (I) : $\text{S}_{\text{N}}2$ reactions are 'stereospecific', indicating that they result in the formation only one stereo-isomers as the product.

Statement (II) : $\text{S}_{\text{N}}1$ reactions generally result in formation of product as racemic mixtures. In the light of the above statements, choose the **correct** answer from the options given below :

- (1) **Statement I** is true but **Statement II** is false
 (2) **Statement I** is false but **Statement II** is true
 (3) Both **Statement I** and **Statement II** is true
 (4) Both **Statement I** and **Statement II** is false

Ans. (3)

Sol. $\text{S}_{\text{N}}2 \rightarrow$ Inversion

$\text{S}_{\text{N}}1 \rightarrow$ Racemisation

67. Match List-I with List-II.

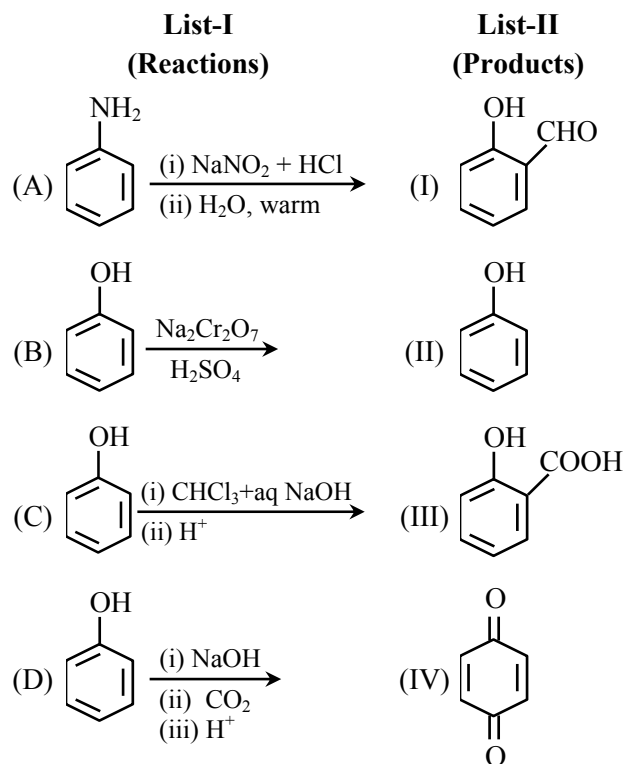

Choose the **correct** answer from the options given below :

- (1) (A)-(III), (B)-(II), (C)-(I), (D)-(IV)
- (2) (A)-(IV), (B)-(II), (C)-(III), (D)-(I)
- (3) (A)-(I), (B)-(IV), (C)-(II), (D)-(III)
- (4) (A)-(II), (B)-(IV), (C)-(I), (D)-(III)

Ans. (4)

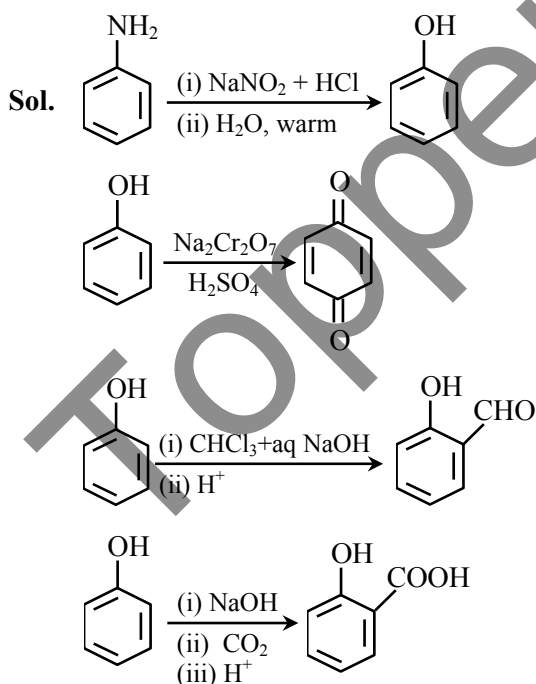

68. Match List-I with List-II.

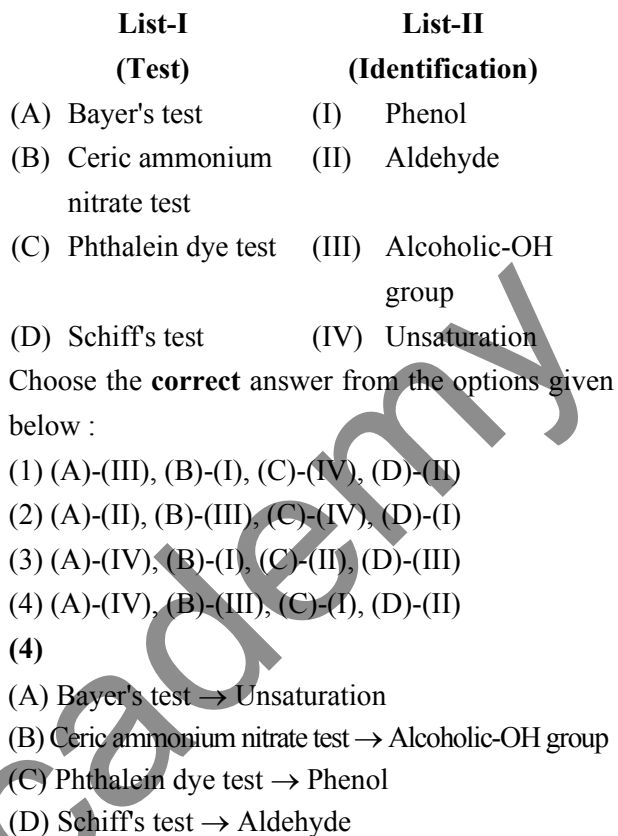

Ans. (4)

Sol. (A) Bayer's test → Unsaturation
 (B) Ceric ammonium nitrate test → Alcoholic-OH group
 (C) Phthalein dye test → Phenol
 (D) Schiff's test → Aldehyde

69. Identify the **incorrect** statements about group 15 elements :

- (A) Dinitrogen is a diatomic gas which acts like an inert gas at room temperature.
- (B) The common oxidation states of these elements are -3, +3 and +5.
- (C) Nitrogen has unique ability to form pπ-pπ multiple bonds.
- (D) The stability of +5 oxidation states increases down the group.
- (E) Nitrogen shows a maximum covalency of 6.

Choose the **correct** answer from the options given below.

- (1) (A), (B), (D) only
- (2) (A), (C), (E) only
- (3) (B), (D), (E) only
- (4) (D) and (E) only

Ans. (4)

Sol. (D) Due to inert pair effect lower oxidation state is more stable.
 (E) Nitrogen belongs to 2nd period and cannot expand its octet.

70. IUPAC name of following hydrocarbon (X) is :

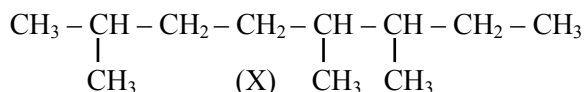

- (1) 2-Ethyl-3,6-dimethylheptane
- (2) 2-Ethyl-2,6-diethylheptane
- (3) 2,5,6-Trimethyloctane
- (4) 3,4,7-Trimethyloctane

Ans. (3)

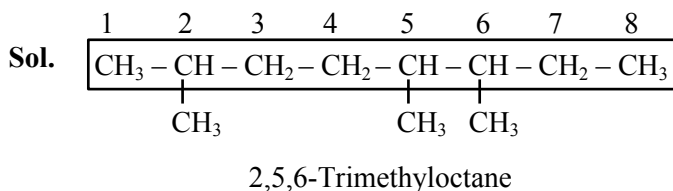

71. The equilibrium $\text{Cr}_2\text{O}_7^{2-} \rightleftharpoons 2\text{CrO}_4^{2-}$ is shifted to the right in :

- (1) an acidic medium
- (2) a basic medium
- (3) a weakly acidic medium
- (4) a neutral medium

Ans. (2)

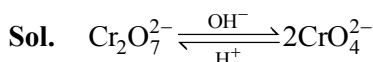

72. Given below are two statements :

Statement (I) : A Buffer solution is the mixture of a salt and an acid or a base mixed in any particular quantities.

Statement (II) : Blood is naturally occurring buffer solution whose pH is maintained by $\text{H}_2\text{CO}_3 / \text{HCO}_3^-$ concentrations.

In the light of the above statements, choose the correct answer from the options given below.

- (1) **Statement I** is false but **Statement II** is true
- (2) Both **Statement I** and **Statement II** is true
- (3) Both **Statement I** and **Statement II** is false
- (4) **Statement I** is true but **Statement II** is false

Ans. (1)

Sol. Buffer solution is a mixture of either weak acid / weak base and its respective conjugate.

Blood is a buffer solution of carbonic acid H_2CO_3 and bicarbonate HCO_3^-

Statement I is false but Statement II is true.

73. The correct sequence of acidic strength of the following aliphatic acids in their decreasing order is :

$\text{CH}_3\text{CH}_2\text{COOH}$, CH_3COOH , $\text{CH}_3\text{CH}_2\text{CH}_2\text{COOH}$, HCOOH

- (1) $\text{HCOOH} > \text{CH}_3\text{COOH} > \text{CH}_3\text{CH}_2\text{COOH} > \text{CH}_3\text{CH}_2\text{CH}_2\text{COOH}$
- (2) $\text{HCOOH} > \text{CH}_3\text{CH}_2\text{CH}_2\text{COOH} > \text{CH}_3\text{CH}_2\text{COOH} > \text{CH}_3\text{COOH}$
- (3) $\text{CH}_3\text{CH}_2\text{CH}_2\text{COOH} > \text{CH}_3\text{CH}_2\text{COOH} > \text{CH}_3\text{COOH} > \text{HCOOH}$
- (4) $\text{CH}_3\text{COOH} > \text{CH}_3\text{CH}_2\text{COOH} > \text{CH}_3\text{CH}_2\text{CH}_2\text{COOH} > \text{HCOOH}$

Ans. (1)

Sol. $\text{CH}_3\text{CH}_2\text{COOH}$, CH_3COOH , $\text{CH}_3\text{CH}_2\text{CH}_2\text{COOH}$, HCOOH

The correct order is :

$\text{HCOOH} > \text{CH}_3\text{COOH} > \text{CH}_3\text{CH}_2\text{COOH} > \text{CH}_3\text{CH}_2\text{CH}_2\text{COOH}$

74. Given below are two statements :

Statement (I) : All the following compounds react with p-toluenesulfonyl chloride.

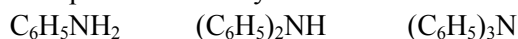

Statement (II) : Their products in the above reaction are soluble in aqueous NaOH.

In the light of the above statements, choose the correct answer from the options given below.

- (1) Both **Statement I** and **Statement II** is false
- (2) **Statement I** is true but **Statement II** is false
- (3) **Statement I** is false but **Statement II** is true
- (4) Both **Statement I** and **Statement II** is true

Ans. (1)

Sol. Hinsberg test given by 1° amine only.

75. The emf of cell $\text{Tl} \left| \text{Tl}^+ \right| \left| \text{Cu}^{2+} \right| \text{Cu}$ is 0.83 V at

298 K. It could be increased by :

- (1) increasing concentration of Tl^+ ions
- (2) increasing concentration of both Tl^+ and Cu^{2+} ions
- (3) decreasing concentration of both Tl^+ and Cu^{2+} ions
- (4) increasing concentration of Cu^{2+} ions

Ans. (4)

Sol.

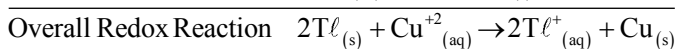

$$E_{\text{cell}} = E_{\text{cell}}^{\circ} - \frac{0.0591}{2} \log \frac{[\text{Tl}^{+}]^2}{[\text{Cu}^{+2}]}$$

E_{cell} increases by increasing concentration of $[\text{Cu}^{+2}]$ ions.

76. Identify the correct statements about p-block elements and their compounds.

- (A) Non metals have higher electronegativity than metals.
(B) Non metals have lower ionisation enthalpy than metals.
(C) Compounds formed between highly reactive nonmetals and highly reactive metals are generally ionic.
(D) The non-metal oxides are generally basic in nature.
(E) The metal oxides are generally acidic or neutral in nature.

- (1) (D) and (E) only (2) (A) and (C) only
(3) (B) and (E) only (4) (B) and (D) only

Ans. (2)

Sol. As electronegativity increases non-metallic nature increases.

Along the period ionisation energy increases.

High electronegativity difference results in ionic bond formation.

Oxides of metals are generally basic and that of non-metals are acidic in nature.

77. Given below are two statements :

Statement (I) : Kjeldahl method is applicable to estimate nitrogen in pyridine.

Statement (II) : The nitrogen present in pyridine can easily be converted into ammonium sulphate in Kjeldahl method.

In the light of the above statements, choose the **correct** answer from the options given below.

- (1) Both **Statement I** and **Statement II** is false
(2) **Statement I** is false but **Statement II** is true
(3) Both **Statement I** and **Statement II** is true
(4) **Statement I** is true but **Statement II** is false

Ans. (1)

Sol. Nitrogen present in pyridine can not be estimated by Kjeldahl method as the nitrogen present in pyridine can not be easily converted into ammonium sulphate.

78. The reaction ;

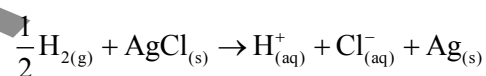

occurs in which of the following galvanic cell :

- (1) $\text{Pt} | \text{H}_{2(g)} | \text{HCl}_{(\text{soln.})} | \text{AgCl}_{(s)} | \text{Ag}$
(2) $\text{Pt} | \text{H}_{2(g)} | \text{HCl}_{(\text{soln.})} | \text{AgNO}_{3(aq)} | \text{Ag}$
(3) $\text{Pt} | \text{H}_{2(g)} | \text{KCl}_{(\text{soln.})} | \text{AgCl}_{(s)} | \text{Ag}$
(4) $\text{Ag} | \text{AgCl}_{(s)} | \text{KCl}_{(\text{soln.})} | \text{AgNO}_{3(aq)} | \text{Ag}$

Ans. (3)

Sol. Anodic half cell

Gas – gas ion electrode

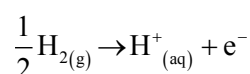

Cathodic Reaction

Metal-metal insoluble salt anion electrode

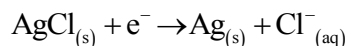
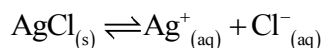
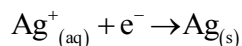

Overall redox reaction

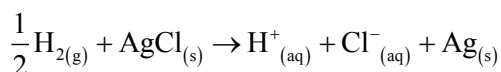

Cell Representation

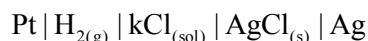

79. Given below are two statements :

Statement (I) : Fusion of MnO_2 with KOH and an oxidising agent gives dark green K_2MnO_4 .

Statement (II) : Manganate ion on electrolytic oxidation in alkaline medium gives permanganate ion.

In the light of the above statements, choose the **correct** answer from the options given below.

- (1) Both **Statement I** and **Statement II** is true
- (2) Both **Statement I** and **Statement II** is false
- (3) **Statement I** is true but **Statement II** is false
- (4) **Statement I** is false but **Statement II** is true

Ans. (1)



Dark green

Electrolytic oxidation in alkaline medium :

At anode :

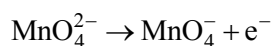

80. Match **List-I** with **List-II**.

List-I (Complex ion)	List-II (Spin only magnetic moment in B.M.)
(A) $[\text{Cr}(\text{NH}_3)_6]^{3+}$	(I) 4.90
(B) $[\text{NiCl}_4]^{2-}$	(II) 3.87
(C) $[\text{CoF}_6]^{3-}$	(III) 0.0
(D) $[\text{Ni}(\text{CN})_4]^{2-}$	(IV) 2.83

Choose the **correct** answer from the options given below :

- (1) (A)-(I), (B)-(IV), (C)-(II), (D)-(III)
- (2) (A)-(IV), (B)-(III), (C)-(I), (D)-(II)
- (3) (A)-(II), (B)-(IV), (C)-(I), (D)-(III)
- (4) (A)-(II), (B)-(III), (C)-(I), (D)-(IV)

Ans. (3)

Sol. (A) $[\text{Cr}(\text{NH}_3)_6]^{3+}$

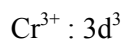

$n = 3$ (unpaired electrons)

$\mu \approx 3.87$ B.M. (II)

(B) $[\text{NiCl}_4]^{2-}$

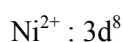

$n = 2$

$\mu \approx 2.83$ B.M. (IV)

(C) $[\text{CoF}_6]^{3-}$

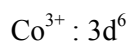

$n = 4$

$\mu \approx 4.90$ B.M. (I)

(D) $[\text{Ni}(\text{CN})_4]^{2-}$

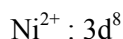

$n = 0$

$\mu = 0$ B.M. (III)

SECTION-B

81. $\Delta_{\text{vap}} H^\ominus$ for water is $+40.49 \text{ kJ mol}^{-1}$ at 1 bar and 100°C . Change in internal energy for this vapourisation under same condition is _____ kJ mol^{-1} . (Integer answer)

(Given $R = 8.3 \text{ JK}^{-1} \text{ mol}^{-1}$)

Ans. (38)

Sol. $\text{H}_2\text{O}(\ell) \rightleftharpoons \text{H}_2\text{O}(\text{g}) \quad \Delta H_{\text{vap}}^0 = 40.79 \text{ kJ / mole}$

$$\Delta H_{\text{vap}}^0 = \Delta U_{\text{vap}}^0 + \Delta n_g RT$$

$$40.79 = \Delta U_{\text{vap}}^0 + \frac{1 \times 8.3 \times 373.15}{1000}$$

$$\Delta U_{\text{vap}}^0 = 40.79 - 3.0971$$

$$= 37.6929$$

$$\Delta U_{\text{vap}}^0 \approx 38$$

82. Number of molecules having bond order 2 from the following molecule is _____.

$\text{C}_2, \text{O}_2, \text{Be}_2, \text{Li}_2, \text{Ne}_2, \text{N}_2, \text{He}_2$

Ans. (2)

Sol. C_2

$$(12e^-) : \sigma 1s^2, \sigma^* 1s^2, \sigma 2s^2, \sigma^* 2s^2 \left[\pi 2p_x^2 = \pi 2p_y^2 \right]$$

$$\text{B.O.} = \frac{8-4}{2} = 2$$

O_2

$$(16e^-) : \sigma 1s^2, \sigma^* 1s^2, \sigma 2s^2, \sigma^* 2s^2, \sigma 2p_z^2$$

$$\left[\pi 2p_x^2 = \pi 2p_y^2 \right] \left[\pi^* 2p_x^1 = \pi^* 2p_y^1 \right]$$

$$\text{B.O.} = \frac{10-6}{2} = 2$$

Be_2

$$(8e^-) : \sigma 1s^2, \sigma^* 1s^2, \sigma 2s^2, \sigma^* 2s^2$$

$$\text{B.O.} = \frac{4-4}{2} = 0$$

Li_2

$$(6e^-) : \sigma 1s^2, \sigma^* 1s^2, \sigma 2s^2$$

$$\text{B.O.} = \frac{4-2}{2} = 1$$

Ne_2

$$(20e^-) : \sigma 1s^2, \sigma^* 1s^2, \sigma 2s^2, \sigma^* 2s^2, \sigma 2p_z^2$$

$$\left[\pi 2p_x^2 = \pi 2p_y^2 \right] \left[\pi^* 2p_x^2 = \pi^* 2p_y^2 \right] \sigma^* 2p_z^2$$

$$\text{B.O.} = \frac{10-10}{2} = 0$$

N_2

$$(14e^-) : \sigma 1s^2, \sigma^* 1s^2, \sigma 2s^2, \sigma^* 2s^2 \left[\pi 2p_x^2 = \pi 2p_y^2 \right] \sigma 2p_z^2$$

$$\text{B.O.} = \frac{10-4}{2} = 6$$

He_2

$$(4e^-) : \sigma 1s^2, \sigma^* 1s^2$$

$$\text{B.O.} = \frac{2-2}{2} = 0$$

83. Total number of optically active compounds from the following is _____.

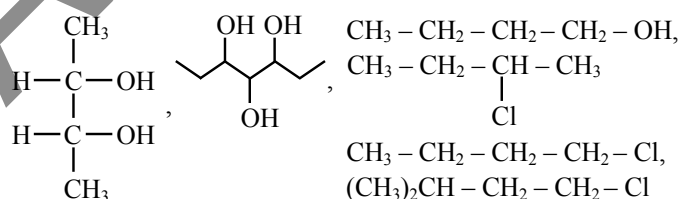

Ans. (1)

Sol. $\text{CH}_3-\text{CH}_2-\underset{\text{Cl}}{\text{CH}}-\text{CH}_3$

84. The total number of carbon atoms present in tyrosine, an amino acid, is _____.

Ans. (9)

Sol. Tyrosine

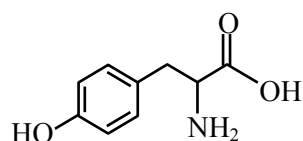

Number of carbon atoms = 9

85. Two moles of benzaldehyde and one mole of acetone under alkaline conditions using aqueous NaOH after heating gives x as the major product. The number of π bonds in the product x is

Ans. (9)

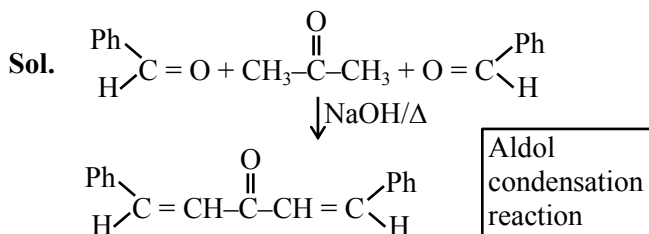

86. Total number of aromatic compounds among the following compounds is _____.

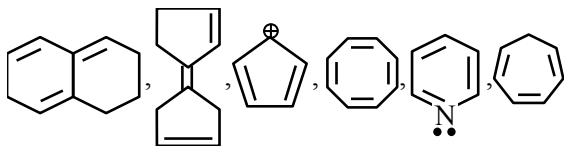

Ans. (1)

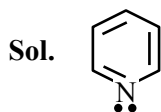

87. Molality of an aqueous solution of urea is 4.44 m. Mole fraction of urea in solution is $x \times 10^{-3}$. Value of x is _____. (integer answer)

Ans. (74)

Sol. Molality of urea is 4.44 m, that means 4.44 moles of urea present in 1000 gm of water.

$$\therefore X_{\text{urea}} = \frac{4.44}{4.44 + \frac{1000}{18}} = 0.0740$$

OR

$$74 \times 10^{-3}$$

$$X = 74$$

88. Total number of unpaired electrons in the complex ion $[\text{Co}(\text{NH}_3)_6]^{3+}$ and $[\text{NiCl}_4]^{2-}$ is

Ans. (2)

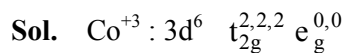

Unpaired $e^- = 0$



Unpaired $e^- = 2$

89. Wavenumber for a radiation having 5800 Å wavelength is $x \times 10 \text{ cm}^{-1}$. The value of x is _____.

Ans. (1724)

Sol. $\bar{\nu} (\text{wave no.}) = \frac{1}{\lambda} = \frac{1}{5800 \times 10^{-8} \text{ cm}} = 17241$

OR

$$1724 \times 10 \text{ cm}^{-1} \Rightarrow x = 1724$$

90. A solution is prepared by adding 1 mole ethyl alcohol in 9 mole water. The mass percent of solute in the solution is _____. (Integer Answer) (Given : Molar mass in g mol^{-1} Ethyl alcohol : 46, water : 18)

Ans. (22)

Sol. Mass percent of Alcohol

$$= \frac{\text{Mass of ethyl alcohol}}{\text{Total mass of solution}} \times 100$$

$$= \frac{1 \times 46}{1 \times 46 + 9 \times 18} \times 100 = \frac{4600}{208}$$

$$= 22.11 \quad \text{Or } 22$$

FINAL JEE-MAIN EXAMINATION – APRIL, 2024

(Held On Tuesday 09th April, 2024)

TIME : 9 : 00 AM to 12 : 00 NOON

MATHEMATICS

TEST PAPER WITH SOLUTION

SECTION-A

1. Let the line L intersect the lines
 $x - 2 = -y = z - 1$, $2(x + 1) = 2(y - 1) = z + 1$
 and be parallel to the line $\frac{x-2}{3} = \frac{y-1}{1} = \frac{z-2}{2}$.

Then which of the following points lies on L ?

- (1) $\left(-\frac{1}{3}, 1, 1\right)$ (2) $\left(-\frac{1}{3}, 1, -1\right)$
 (3) $\left(-\frac{1}{3}, -1, -1\right)$ (4) $\left(-\frac{1}{3}, -1, 1\right)$

Ans. (2)

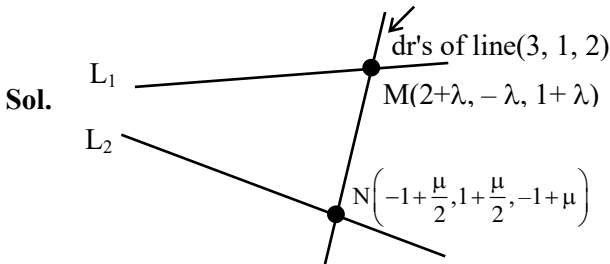

$$L_1: \frac{x-2}{1} = \frac{y}{-1} = \frac{z-1}{1} = \lambda$$

$$L_2: \frac{x+1}{\frac{1}{2}} = \frac{y-1}{\frac{1}{2}} = \frac{z+1}{1} = \mu$$

dr of line MN will be

$\langle 3 + \lambda - \frac{\mu}{2}, -1 - \lambda - \frac{\mu}{2}, 2 + \lambda - \mu \rangle$ & it will be proportional to $\langle 3, 1, 2 \rangle$

$$\therefore \frac{3 + \lambda - \frac{\mu}{2}}{3} = \frac{-1 - \lambda - \frac{\mu}{2}}{1} = \frac{2 + \lambda - \mu}{2}$$

$$\begin{aligned} \underbrace{\frac{3 + \lambda - \frac{\mu}{2}}{3}}_{4\lambda + \mu = -6} &= \underbrace{\frac{-1 - \lambda - \frac{\mu}{2}}{1}}_{4 + 3\lambda = 0} = \frac{2 + \lambda - \mu}{2} \end{aligned}$$

$$\Rightarrow \lambda = -\frac{4}{3} \text{ \& \ } \mu = -\frac{2}{3}$$

\therefore Coordinate of M will be $\left(\frac{2}{3}, \frac{4}{3}, -\frac{1}{3}\right)$

and equation of required line will be.

$$\frac{x - \frac{2}{3}}{3} = \frac{y - \frac{4}{3}}{1} = \frac{z + \frac{1}{3}}{2} = k$$

So any point on this line will be

$$\left(\frac{2}{3} + 3k, \frac{4}{3} + k, -\frac{1}{3} + 2k\right)$$

$$\therefore \frac{2}{3} + 3k = -\frac{1}{3} \Rightarrow k = -\frac{1}{3}$$

\therefore Point lie on the line for

$$k = -\frac{1}{3} \text{ is } \left(-\frac{1}{3}, 1, -1\right)$$

2. The parabola $y^2 = 4x$ divides the area of the circle $x^2 + y^2 = 5$ in two parts. The area of the smaller part is equal to :

(1) $\frac{2}{3} + 5 \sin^{-1}\left(\frac{2}{\sqrt{5}}\right)$ (2) $\frac{1}{3} + 5 \sin^{-1}\left(\frac{2}{\sqrt{5}}\right)$

(3) $\frac{1}{3} + \sqrt{5} \sin^{-1}\left(\frac{2}{\sqrt{5}}\right)$ (4) $\frac{2}{3} + \sqrt{5} \sin^{-1}\left(\frac{2}{\sqrt{5}}\right)$

Ans. (1)

Sol. $y^2 = 4x$
 $x^2 + y^2 = 5$

\therefore Area of shaded region as shown in the figure will be

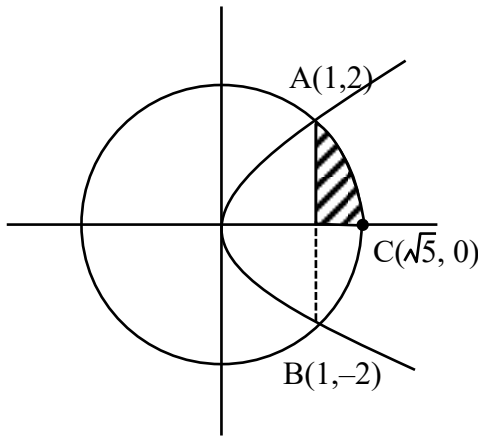

$$A_1 = \int_0^1 \sqrt{4x} \, dx + \int_1^{\sqrt{5}} \sqrt{5-x^2} \, dx$$

$$= \frac{4}{3} \left[x^{\frac{3}{2}} \right]_0^1 + \left[\frac{x}{2} \sqrt{5-x^2} + \frac{5}{2} \sin^{-1} \frac{x}{\sqrt{5}} \right]_1^{\sqrt{5}}$$

$$= \frac{1}{3} + \frac{5\pi}{4} - \frac{5}{2} \sin^{-1} \left(\frac{1}{\sqrt{5}} \right)$$

\therefore Required Area = $2 A_1$

$$= \frac{2}{3} + \frac{5\pi}{2} - 5 \sin^{-1} \left(\frac{1}{\sqrt{5}} \right)$$

$$= \frac{2}{3} + 5 \left(\frac{\pi}{2} - \sin^{-1} \frac{1}{\sqrt{5}} \right)$$

$$= \frac{2}{3} + 5 \cos^{-1} \frac{1}{\sqrt{5}}$$

$$= \frac{2}{3} + 5 \sin^{-1} \left(\frac{2}{\sqrt{5}} \right)$$

3. The solution curve, of the differential equation

$$2y \frac{dy}{dx} + 3 = 5 \frac{dy}{dx}, \text{ passing through the point}$$

$(0, 1)$ is a conic, whose vertex lies on the line :

- (1) $2x + 3y = 9$ (2) $2x + 3y = -9$
 (3) $2x + 3y = -6$ (4) $2x + 3y = 6$

Ans. (1)

Sol. $(2y-5) \frac{dy}{dx} = -3$

$$(2y-5)dy = -3dx$$

$$2 \cdot \frac{y^2}{2} - 5y = -3x + \lambda$$

\therefore Curve passes through $(0, 1)$

$$\Rightarrow \lambda = -4$$

\therefore Curve will be

$$\left(y - \frac{5}{2} \right)^2 = -3 \left(x - \frac{3}{4} \right)$$

\therefore Vertex of parabola will be $\left(\frac{3}{4}, \frac{5}{2} \right)$

$$\therefore 2x + 3y = 9$$

4. A ray of light coming from the point P (1, 2) gets reflected from the point Q on the x-axis and then passes through the point R (4, 3). If the point S (h, k) is such that PQRS is a parallelogram, then hk^2 is equal to :

- (1) 80 (2) 90
 (3) 60 (4) 70

Ans. (4)

Sol.

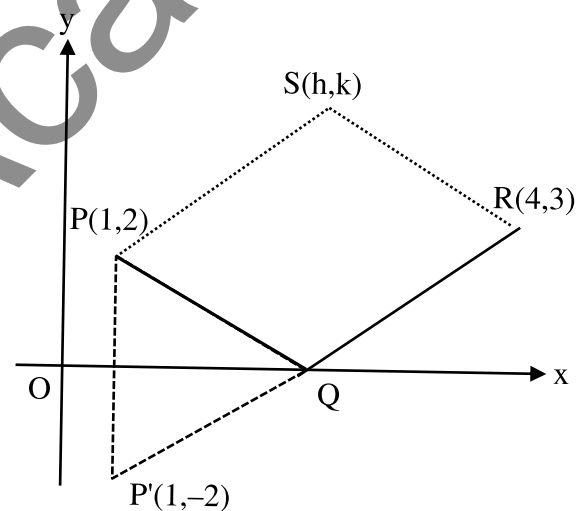

Image of P wrt x-axis will be $P'(1, -2)$ equation of line joining $P'R$ will be

$$y - 3 = \frac{5}{3}(x - 4)$$

Above line will meet x-axis at Q where

$$y = 0 \Rightarrow x = \frac{11}{5}$$

$$\therefore Q \left(\frac{11}{5}, 0 \right)$$

\therefore PQRS is parallelogram so their diagonals will bisect each other

$$\Rightarrow \frac{4+1}{2} = \frac{11+h}{5} \& \frac{2+3}{2} = \frac{k+0}{2}$$

$$\Rightarrow h = \frac{14}{5} \& k = 5$$

$$\therefore hk^2 = \frac{14}{5} \times 5^2 = 70$$

5. Let $\lambda, \mu \in \mathbb{R}$. If the system of equations

$$3x + 5y + \lambda z = 3$$

$$7x + 11y - 9z = 2$$

$$97x + 155y - 189z = \mu$$

has infinitely many solutions, then $\mu + 2\lambda$ is equal to :

(1) 25 (2) 24

(3) 27 (4) 22

Ans. (1)

Sol. $3x + 5y + \lambda z = 3$

$$7x + 11y - 9z = 2$$

$$97x + 155y - 189z = \mu$$

$$93x + 155y + 31\lambda z = 93$$

$$97x + 155y - 189z = \mu$$

$$\begin{array}{r} - & - & + & - \\ \hline -4x + (31\lambda + 189)z = 93 - \mu \end{array}$$

$$1085x + 1705y - 1395z = 310$$

$$1067x + 1705y - 2079z = 11\mu$$

$$\begin{array}{r} - & - & + & - \\ \hline 18x + 684z = 310 - 11\mu \end{array}$$

$$-36x + 9(31\lambda + 189)z = 9(93 - \mu)$$

$$36x + 1368z = 2(310 - 11\mu)$$

$$(279\lambda + 3069)z = 1457 - 31\mu$$

for infinite solutions -

$$\lambda = \frac{-3069}{279} = \frac{-341}{31}$$

$$\mu = \frac{1457}{31}$$

$$\mu + 2\lambda = \frac{1457 - 682}{31} = \frac{775}{31} = 25$$

6. The coefficient of x^{70} in $x^2(1+x)^{98} + x^3(1+x)^{97} + x^4(1+x)^{96} + \dots + x^{54}(1+x)^{46}$ is ${}^{99}C_p - {}^{46}C_q$.

Then a possible value to $p + q$ is :

(1) 55 (2) 61

(3) 68 (4) 83

Ans. (4)

Sol. $x^2(1+x)^{98} + x^3(1+x)^{97} + x^4(1+x)^{96} + \dots + x^{54}(1+x)^{46}$

Coeff. of $x^{70} : {}^{98}C_{68} + {}^{97}C_{67} + {}^{96}C_{66} + \dots$

$${}^{47}C_{17} + {}^{46}C_{16}$$

$$= {}^{46}C_{30} + {}^{47}C_{30} + \dots + {}^{98}C_{30}$$

$$= ({}^{46}C_{31} + {}^{46}C_{30}) + {}^{47}C_{30} + \dots + {}^{98}C_{30} - {}^{46}C_{31}$$

$$= {}^{47}C_{31} + {}^{47}C_{30} + \dots + {}^{98}C_{30} - {}^{46}C_{31}$$

.....

$$= {}^{99}C_{31} - {}^{46}C_{31} = {}^{99}C_p - {}^{46}C_q$$

Possible values of $(p + q)$ are 62, 83, 99, 46

$$\Rightarrow p + q = 83$$

7. Let

$$\int \frac{2 - \tan x}{3 + \tan x} dx = \frac{1}{2} (\alpha x + \log_e |\beta \sin x + \gamma \cos x|) + C$$

, where C is the constant of integration.

Then $\alpha + \frac{\gamma}{\beta}$ is equal to :

(1) 3 (2) 1

(3) 4 (4) 7

Ans. (3)

Sol. $\int \frac{2 - \tan x}{3 + \tan x} dx = \int \frac{2 \cos x - \sin x}{3 \cos x + \sin x} dx$

$$2 \cos x - \sin x = A(3 \cos x + \sin x) + B(\cos x - 3 \sin x)$$

$$3A + B = 2$$

$$A - 3B = -1$$

10. Let $\vec{OA} = 2\vec{a}, \vec{OB} = 6\vec{a} + 5\vec{b}$ and $\vec{OC} = 3\vec{b}$, where O is the origin. If the area of the parallelogram with adjacent sides \vec{OA} and \vec{OC} is 15 sq. units, then the area (in sq. units) of the quadrilateral OABC is equal to :

- (1) 38 (2) 40
(3) 32 (4) 35

Ans. (4)

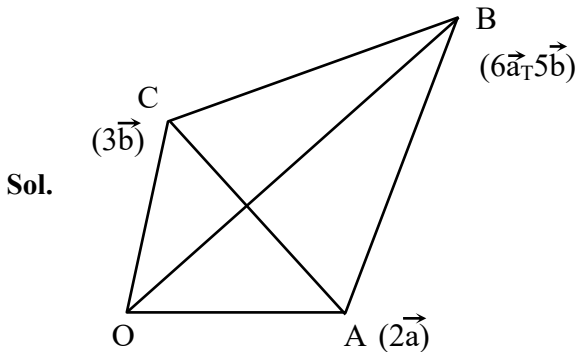

Area of parallelogram having sides \vec{OA} & $\vec{OC} = |\vec{OA} \times \vec{OC}| = |2\vec{a} \times 3\vec{b}| = 15$

$$6|\vec{a} \times \vec{b}| = 15$$

$$\Rightarrow |\vec{a} \times \vec{b}| = \frac{5}{2} \dots\dots(1)$$

Area of quadrilateral

$$\begin{aligned} OABC &= \frac{1}{2} |\vec{d}_1 \times \vec{d}_2| \\ &= \frac{1}{2} |\vec{AC} \times \vec{OB}| = \frac{1}{2} |(3\vec{b} - 2\vec{a}) \times (6\vec{a} + 5\vec{b})| \\ &= \frac{1}{2} |18\vec{b} \times \vec{a} - 10\vec{a} \times \vec{b}| = 14|\vec{a} \times \vec{b}| \\ &= 14 \times \frac{5}{2} = 35 \end{aligned}$$

11. If the domain of the function

$$f(x) = \sin^{-1}\left(\frac{x-1}{2x+3}\right) \text{ is } R - (\alpha, \beta)$$

then $12\alpha\beta$ is equal to :

- (1) 36 (2) 24
(3) 40 (4) 32

Ans. (4)

Sol. Domain of $f(x) = \sin^{-1}\left(\frac{x-1}{2x+3}\right)$ is

$$2x+3 \neq 0 \text{ \& } x \neq \frac{-3}{2} \text{ and } \left|\frac{x-1}{2x+3}\right| \leq 1$$

$$|x-1| \leq |2x+3|$$

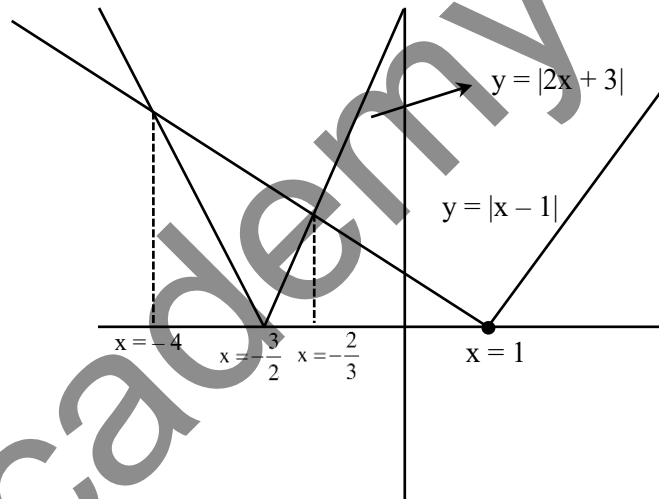

$$\text{For } |2x+3| \geq |x-1|$$

$$x \in (-\infty, -4] \cup \left(-\frac{2}{3}, \infty\right)$$

$$\alpha = -4 \text{ \& } \beta = -\frac{2}{3} : 12\alpha\beta = 32$$

12. If the sum of series

$$\frac{1}{1 \cdot (1+d)} + \frac{1}{(1+d)(1+2d)} + \dots + \frac{1}{(1+9d)(1+10d)}$$

is equal to 5, then $50d$ is equal to :

- (1) 20 (2) 5
(3) 15 (4) 10

Ans. (2)

Sol. $\frac{1}{1 \cdot (1+d)} + \frac{1}{(1+d)(1+2d)} + \dots$

$$\frac{1}{(1+9d)(1+10d)} = 5$$

$$\frac{1}{d} \left[\frac{(1+d)-1}{1 \cdot (1+d)} + \frac{(1+2d)-(1-d)}{(1+d)(1+2d)} \right] + \dots$$

$$\frac{(1+10d)-(1+9d)}{(1+9d)(1+10d)} = 5$$

$$\frac{1}{d} \left[\left(1 - \frac{1}{1+d} \right) + \left(\frac{1}{1+d} - \frac{1}{1+2d} \right) + \dots \right]$$

$$\left[\frac{1}{1+9d} - \frac{1}{1+10d} \right] = 5$$

$$\frac{1}{d} \left[1 - \frac{1}{(1+10d)} \right] = 5$$

$$\frac{10d}{1+10d} = 5d$$

$$50d = 5$$

13. Let $f(x) = ax^3 + bx^2 + cx + 41$ be such that

$$f(1) = 40, f'(1) = 2 \text{ and } f''(1) = 4.$$

Then $a^2 + b^2 + c^2$ is equal to :

- (1) 62 (2) 73
 (3) 54 (4) 51

Ans. (4)

Sol. $f(x) = ax^3 + bx^2 + cx + 41$

$$f'(x) = 3ax^2 + 2bx + cx$$

$$\Rightarrow f'(1) = 3a + 2b + c = 2 \dots \dots \dots (1)$$

$$f''(x) = 6ax + 2b$$

$$\Rightarrow f''(1) = 6a + 2b = 4$$

$$3a + b = 2 \dots \dots \dots (2)$$

$$(1) - (2)$$

$$b + c = 0 \dots \dots \dots (3)$$

$$f(1) = 40$$

$$a + b + c + 41 = 40$$

use (3)

$$a + 41 = 40$$

by (2)

$$-3 + b = 2 \Rightarrow b = 5 \text{ \& } c = -5$$

$$a^2 + b^2 + c^2 = 1 + 25 + 25 = 51$$

14. Let a circle passing through $(2, 0)$ have its centre at the point (h, k) . Let (x_c, y_c) be the point of intersection of the lines $3x + 5y = 1$ and $(2 + c)x + 5c^2y = 1$. If $h = \lim_{c \rightarrow 1} x_c$ and $k = \lim_{c \rightarrow 1} y_c$, then the equation of the circle is :

- (1) $25x^2 + 25y^2 - 20x + 2y - 60 = 0$
 (2) $5x^2 + 5y^2 - 4x - 2y - 12 = 0$
 (3) $25x^2 + 25y^2 - 2x + 2y - 60 = 0$
 (4) $5x^2 + 5y^2 - 4x + 2y - 12 = 0$

Ans. (1)

Sol. $(2 + c)x + 5c^2 \left(\frac{1 - 3x}{5} \right) = 1$

$$x = \frac{1 - c^2}{2 + c - 3c^2}, y = \frac{1 - 3x}{5} = \frac{c - 1}{5(2 + c - 3c^2)}$$

$$h = \lim_{c \rightarrow 1} \frac{(1 - c)(1 + c)}{(1 - c)(2 + 3c)} = \frac{2}{5}$$

$$k = \lim_{c \rightarrow 1} \frac{c - 1}{-5(c - 1)(3c + 2)} = -\frac{1}{25}$$

Centre $\left(\frac{2}{25}, -\frac{1}{25} \right)$,

$$r = \sqrt{\left(2 - \frac{2}{25} \right)^2 + \left(0 - \frac{1}{25} \right)^2} = \sqrt{\frac{64}{25} + \frac{1}{625}}$$

$$r = \frac{\sqrt{161}}{25}$$

$$\left(x - \frac{2}{25} \right)^2 + \left(y + \frac{1}{25} \right)^2 = \frac{161}{125}$$

$$\Rightarrow 25x^2 + 25y^2 - 20x + 2y - 60 = 0$$

15. The shortest distance between the line

$$\frac{x - 3}{4} = \frac{y + 7}{-11} = \frac{z - 1}{5} \text{ and } \frac{x - 5}{3} = \frac{y - 9}{-6} = \frac{z + 2}{1}$$

is :

- (1) $\frac{187}{\sqrt{563}}$ (2) $\frac{178}{\sqrt{563}}$

$$\Rightarrow \int \frac{dt}{(-8)(t)} = \int \frac{dx}{5x}$$

$$\Rightarrow \frac{-1}{8} \ln|t| = \frac{1}{5} \ln|x| + \ln C$$

$$\Rightarrow -5 \ln|t| = 8 \ln|x| + \ln K$$

$$\Rightarrow \ln x^8 + \ln |t^5| + \ln K = 0$$

$$\Rightarrow x^8 |t^5| = C$$

$$\Rightarrow x^8 |1 - 4V^2|^5 = C$$

$$\Rightarrow x^8 \left| \frac{x^2 - 4y^2}{x^2} \right|^5 = C$$

$$\Rightarrow |x^2 - 4y^2|^5 = Cx^2$$

given $y(1) = 0$

$$\Rightarrow |1|^5 = C \Rightarrow C = 1$$

$$\Rightarrow |x^2 - 4y^2|^5 = x^2$$

18. Let three vectors $\vec{a} = \alpha\hat{i} + 4\hat{j} + 2\hat{k}$,
 $\vec{b} = 5\hat{i} + 3\hat{j} + 4\hat{k}$, $\vec{c} = x\hat{i} + y\hat{j} + z\hat{k}$ form a triangle
such that $\vec{c} = \vec{a} - \vec{b}$ and the area of the triangle is
 $5\sqrt{6}$. if α is a positive real number, then $|\vec{c}|^2$ is :

- (1) 16 (2) 14
(3) 12 (4) 10

Ans. (2)

Sol. $\vec{c} = \vec{a} - \vec{b}$
 $\Rightarrow (x, y, z) = (\alpha - 5, 1, -2)$
 $\Rightarrow x = \alpha - 5, y = 1, z = -2$ (1)

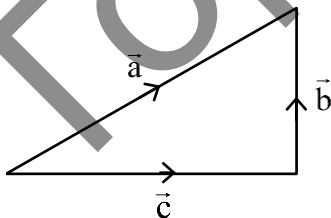

Area of $\Delta = 5\sqrt{6}$ (given)

$$\frac{1}{2} |\vec{a} \times \vec{c}| = 5\sqrt{6}$$

$$\begin{vmatrix} \hat{i} & \hat{j} & \hat{k} \\ \alpha & 4 & 2 \\ x & 1 & -2 \end{vmatrix} = 10\sqrt{6}$$

$$\Rightarrow |-10\hat{i} - \hat{j}(-2\alpha - 2x) + \hat{k}(\alpha - 4x)| = 10\sqrt{6}$$

$$\Rightarrow (2\alpha + 2\alpha - 10)^2 + (\alpha - 4\alpha + 20)^2 = 500$$

$$\Rightarrow (4\alpha - 10)^2 + (20 - 3\alpha)^2 = 500$$

$$\Rightarrow 25\alpha^2 - 80\alpha - 120\alpha = 0$$

$$\Rightarrow \alpha(25\alpha - 200) = 0$$

$$\Rightarrow \alpha = 8 \text{ (given } \alpha \text{ is +ve number)}$$

$$\Rightarrow x = \alpha - 5 = 3$$

$$|\vec{c}|^2 = x^2 + y^2 + z^2$$

$$= 9 + 1 + 4$$

$$= 14$$

19. Let α, β be the roots of the equation

$$x^2 + 2\sqrt{2}x - 1 = 0. \text{ The quadratic equation,}$$

whose roots are $\alpha^4 + \beta^4$ and $\frac{1}{10}(\alpha^6 + \beta^6)$, is :

(1) $x^2 - 190x + 9466 = 0$

(2) $x^2 - 195x + 9466 = 0$

(3) $x^2 - 195x + 9506 = 0$

(4) $x^2 - 180x + 9506 = 0$

Ans. (3)

Sol. $x^2 + 2\sqrt{2}x - 1 = 0$

$$\alpha + \beta = -2\sqrt{2}$$

$$\alpha\beta = -1$$

$$\alpha^4 + \beta^4 = (\alpha^2 + \beta^2)^2 - 2\alpha^2\beta^2$$

$$= ((\alpha + \beta)^2 - 2\alpha\beta)^2 - 2(\alpha\beta)^2$$

$$= (8 + 2)^2 - 2(-1)^2$$

$$= 100 - 2 = 98$$

$$\alpha^6 + \beta^6 = (\alpha^3 + \beta^3)^2 - 2\alpha^3\beta^3$$

$$= ((\alpha + \beta)((\alpha + \beta)^2 - 3\alpha\beta))^2 - 2(\alpha\beta)^3$$

$$= (-2\sqrt{2}(8+3))^2 + 2$$

$$= (8)(121) + 2 = 970$$

$$\frac{1}{10}(\alpha^6 + \beta^6) = 97$$

$$x^2 - (98 + 97)x + (98)(97) = 0$$

$$\Rightarrow x^2 - 195x + 9506 = 0$$

20. Let $f(x) = x^2 + 9$, $g(x) = \frac{x}{x-9}$ and

$a = fog(10)$, $b = gof(3)$. If e and l denote the eccentricity and the length of the latus rectum of

the ellipse $\frac{x^2}{a} + \frac{y^2}{b} = 1$, then $8e^2 + l^2$ is equal to.

(1) 16

(2) 8

(3) 6

(4) 12

Ans. (2)

Sol. $f(x) = x^2 + 9$ $g(x) = \frac{x}{x-9}$

$$a = f(g(10)) = f\left(\frac{10}{10-9}\right)$$

$$= f(10) = 109$$

$$b = g(f(3)) = g(9+9)$$

$$= g(18) = \frac{18}{9} = 2$$

$$E: \frac{x^2}{109} + \frac{y^2}{2} = 1$$

$$e^2 = 1 - \frac{2}{109} = \frac{107}{109}$$

$$l = \frac{2(2)}{\sqrt{109}} = \frac{4}{\sqrt{109}}$$

$$8e^2 + l^2 = \frac{8(107)}{109} + \frac{16}{109}$$

$$= 8$$

SECTION-B

21. Let a , b and c denote the outcome of three independent rolls of a fair tetrahedral die, whose

four faces are marked 1, 2, 3, 4. If the probability

that $ax^2 + bx + c = 0$ has all real roots is $\frac{m}{n}$,

$\gcd(m, n) = 1$, then $m + n$ is equal to _____.

Ans. (19)

Sol. $a, b, c \in \{1, 2, 3, 4\}$

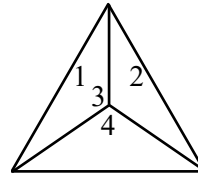

Tetrahedral dice

$$ax^2 + bx + c = 0$$

has all real roots

$$\Rightarrow D \geq 0$$

$$\Rightarrow b^2 - 4ac \geq 0$$

$$\text{Let } b = 1 \Rightarrow 1 - 4ac \geq 0 \text{ (Not feasible)}$$

$$b = 2 \Rightarrow 4 - 4ac \geq 0$$

$$1 \geq ac \Rightarrow a = 1, c = 1,$$

$$b = 3 \Rightarrow 9 - 4ac \geq 0$$

$$\frac{9}{4} \geq ac$$

$$\Rightarrow a = 1, c = 1$$

$$\Rightarrow a = 1, c = 2$$

$$\Rightarrow a = 2, c = 1$$

$$b = 4 \Rightarrow 16 - 4ac \geq 0$$

$$4 \geq ac$$

$$\Rightarrow a = 1, c = 1$$

$$\Rightarrow a = 1, c = 2 \quad \Rightarrow a = 2, c = 1$$

$$\Rightarrow a = 1, c = 3 \quad \Rightarrow a = 3, c = 1$$

$$\Rightarrow a = 1, c = 4 \quad \Rightarrow a = 4, c = 1$$

$$\Rightarrow a = 2, c = 2$$

$$\text{Probability} = \frac{12}{(4)(4)(4)} = \frac{3}{16} = \frac{m}{n}$$

$$m + n = 19$$

22. The sum of the square of the modulus of the elements in the set

$$\{z = a + ib : a, b \in \mathbb{Z}, z \in \mathbb{C}, |z-1| \leq 1, |z-5| \leq |z-5i|\}$$

is _____.

Ans. (9)

Sol. $|z-1| \leq 1$

$$\Rightarrow |(x-1) + iy| \leq 1$$

$$\Rightarrow \sqrt{(x-1)^2 + y^2} \leq 1$$

$$\Rightarrow (x-1)^2 + y^2 \leq 1 \dots\dots\dots (1)$$

Also $|z-5| \leq |z-5i|$

$$(x-5)^2 + y^2 \leq x^2 + (y-5)^2$$

$$-10x \leq -10y$$

$$\Rightarrow x \geq y \dots\dots\dots (2)$$

Solving (1) and (2)

$$\Rightarrow (x-1)^2 + x^2 = 1$$

$$\Rightarrow 2x^2 - 2x = 0$$

$$\Rightarrow x(x-1) = 0$$

$$\Rightarrow x = 0 \text{ or } x = 1$$

$$y = 0 \text{ or } y = 1$$

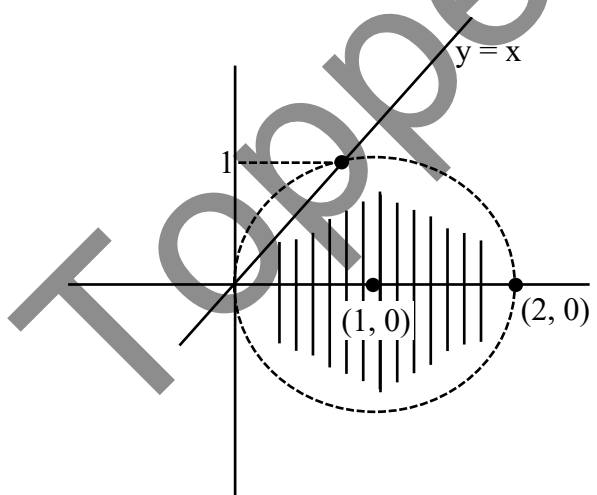

Given $x, y \in \mathbb{I}$

Points (0, 0), (1, 0), (2, 0), (1, 1), (1, -1) to find

$$|z_1|^2 + |z_2|^2 + |z_3|^2 + |z_4|^2 + |z_5|^2$$

$$= 0 + 1 + 4 + 1 + 1 + 1 + 1 = 9$$

23. Let the set of all positive values of λ , for which the point of local minimum of the function

$$(1 + x(\lambda^2 - x^2)) \text{ satisfies } \frac{x^2 + x + 2}{x^2 + 5x + 6} < 0, \text{ be } (\alpha, \beta).$$

Then $\alpha^2 + \beta^2$ is equal to _____.

Ans. (39)

Sol. $\frac{x^2 + x + 2}{x^2 + 5x + 6} < 0$

$$\Rightarrow \frac{1}{(x+2)(x+3)} < 0$$

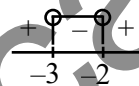

$$x \in (-3, -2) \dots\dots\dots (1)$$

$$f(x) = 1 + x(\lambda^2 - x^2)$$

Finding local minima

$$f'(x) = (\lambda^2 - x^2) + (-2x).x$$

$$\text{Put } f'(x) = 0$$

$$\Rightarrow \lambda^2 = 3x^2$$

$$\Rightarrow x = \pm \frac{\lambda}{\sqrt{3}}$$

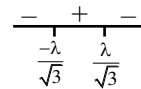

Local min Local max

We want local min

$$\Rightarrow x = \frac{-\lambda}{\sqrt{3}}$$

from (1)

$$x \in (-3, -2)$$

$$-3 < \frac{-\lambda}{\sqrt{3}} < -2$$

$$3\sqrt{3} > \lambda > 2\sqrt{3}$$

$$\alpha = 2\sqrt{3}, \beta = 3\sqrt{3}$$

$$\alpha^2 + \beta^2 = 12 + 27 = 39$$

24. Let

$$\lim_{n \rightarrow \infty} \left(\frac{n}{\sqrt{n^4+1}} - \frac{2n}{(n^2+1)\sqrt{n^4+1}} + \frac{n}{\sqrt{n^4+16}} - \frac{8n}{(n^2+4)\sqrt{n^4+16}} + \dots + \frac{n}{\sqrt{n^4+n^4}} - \frac{2n \cdot n^2}{(n^2+n^2)\sqrt{n^4+n^4}} \right) \text{ be } \frac{\pi}{k},$$

using only the principal values of the inverse trigonometric functions. Then k^2 is equal to _____.

Ans. (32)

Sol.
$$\sum_{r=1}^{\infty} \frac{n}{\sqrt{n^4+r^4}} - \frac{2nr^2}{(n^2+r^2)\sqrt{n^4+r^4}}$$

$$\sum_{r=1}^{\infty} \frac{\frac{1}{n}}{\sqrt{1+\left(\frac{r}{n}\right)^4}} - \frac{2\left(\frac{1}{n}\right)\left(\frac{r}{n}\right)^2}{\left(1+\left(\frac{r}{n}\right)^2\right)\sqrt{1+\left(\frac{r}{n}\right)^4}}$$

$$\Rightarrow \int_0^1 \frac{dx}{\sqrt{1+x^4}} - \frac{2x^2 dx}{(1+x^2)\sqrt{1+x^4}}$$

$$\Rightarrow \int_0^1 \frac{1-x^2}{(1+x^2)\sqrt{1+x^4}} dx$$

$$\Rightarrow \int_0^1 \frac{\frac{1}{x^2}-1}{\left(x+\frac{1}{x}\right)\sqrt{x^2+\frac{1}{x^2}}} dx$$

$$\Rightarrow -\int_0^1 \frac{1-\frac{1}{x^2}}{\left(x+\frac{1}{x}\right)\sqrt{\left(x+\frac{1}{x}\right)^2-2}} dx$$

$$x + \frac{1}{x} = t \Rightarrow 1 - \frac{1}{x^2} dx = dt$$

$$\Rightarrow -\int_{\infty}^2 \frac{dt}{t\sqrt{t^2-2}}$$

$$\Rightarrow -\int_{\infty}^2 \frac{tdt}{t^2\sqrt{t^2-2}}$$

$$\text{take } t^2 - 2 = \alpha^2$$

$$t dt = \alpha d\alpha$$

$$\Rightarrow -\int_{\infty}^{\sqrt{2}} \frac{\alpha d\alpha}{(\alpha^2+2)\alpha}$$

$$\Rightarrow -\int_{\infty}^{\sqrt{2}} \frac{d\alpha}{\alpha^2+2}$$

$$\Rightarrow \left. \frac{-1}{\sqrt{2}} \tan^{-1} \frac{\alpha}{\sqrt{2}} \right]_{\infty}^{\sqrt{2}}$$

$$\Rightarrow \frac{-1}{\sqrt{2}} \left\{ \tan^{-1} 1 \right\} + \frac{1}{\sqrt{2}} \tan^{-1} \infty$$

$$\Rightarrow \frac{1}{\sqrt{2}} \left\{ \frac{\pi}{2} - \frac{\pi}{4} \right\}$$

$$\Rightarrow \frac{\pi}{4\sqrt{2}} = \frac{\pi}{K}$$

$$\text{So } K = 4\sqrt{2}$$

$$K^2 = 32$$

25. The remainder when 428^{2024} is divided by 21 is _____.

Ans. (1)

Sol. $(428)^{2024} = (420 + 8)^{2024}$

$$= (21 \times 20 + 8)^{2024}$$

$$= 21m + 8^{2024}$$

$$\text{Now } 8^{2024} = (8^2)^{1012}$$

$$= (64)^{1012}$$

$$= (63 + 1)^{1012}$$

$$= (21 \times 3 + 1)^{1012}$$

$$= 21n + 1$$

$$\Rightarrow \text{Remainder is 1.}$$

26. Let $f: (0, \pi) \rightarrow \mathbb{R}$ be a function given by

$$f(x) = \begin{cases} \left(\frac{8}{7}\right)^{\frac{\tan 8x}{\tan 7x}}, & 0 < x < \frac{\pi}{2} \\ a - 8, & x = \frac{\pi}{2} \\ (1 + |\cot x|)^{\frac{b}{a}|\tan x|}, & \frac{\pi}{2} < x < \pi \end{cases}$$

Where $a, b \in \mathbb{Z}$. If f is continuous at $x = \frac{\pi}{2}$, then

$a^2 + b^2$ is equal to _____.

Ans. (81)

Sol. LHL at $x = \frac{\pi}{2}$

$$\lim_{x \rightarrow \frac{\pi}{2}^-} \left(\frac{8}{7}\right)^{\frac{\tan 8x}{\tan 7x}} = \left(\frac{8}{7}\right)^0 = 1$$

RHL at $x = \frac{\pi}{2}$

$$\lim_{x \rightarrow \frac{\pi}{2}^+} (1 + |\cot x|)^{\frac{b}{a}|\tan x|}$$

$$= e^{\lim_{x \rightarrow \frac{\pi}{2}^+} |\cot x| \frac{b}{a} |\tan x|} = e^{\frac{b}{a}}$$

$$\Rightarrow 1 = a - 8 = e^{\frac{b}{a}}$$

$$\Rightarrow a = 9, b = 0$$

$$\Rightarrow a^2 + b^2 = 81$$

27. Let A be a non-singular matrix of order 3. If $\det(3\text{adj}(2\text{adj}((\det A)A))) = 3^{-13} \cdot 2^{-10}$ and $\det(3\text{adj}(2A)) = 2^m \cdot 3^n$, then $|3m + 2n|$ is equal to _____.

Ans. (14)

Sol. $|3 \text{adj}(2\text{adj}(|A|A))| = |3\text{adj}(2|A|^2 \text{adj}(A))|$
 $= |3 \cdot 2^2 |A|^4 \text{adj}(\text{adj}(A))| = 2^6 3^3 |A|^{12} |A|^4$
 $= 2^6 3^3 |A|^{16} = 2^{-10} 3^{-13}$
 $\Rightarrow |A|^{16} = 2^{-16} 3^{-16} \Rightarrow |A| = 2^{-1} 3^{-1}$

$$\begin{aligned} \text{Now } |3\text{adj}(2A)| &= |3 \cdot 2^2 \text{adj}(A)| \\ &= 2^6 3^3 |A|^2 = 2^{-m} 3^{-n} \\ \Rightarrow 2^6 3^3 2^{-2} 3^{-2} &= 2^{-m} 3^{-n} \\ \Rightarrow 2^{-m} 3^{-n} &= 2^4 3^1 \\ \Rightarrow m &= -4, n = -1 \\ \Rightarrow |3m + 2n| &= |-12 - 2| = 14 \end{aligned}$$

28. Let the centre of a circle, passing through the point $(0, 0)$, $(1, 0)$ and touching the circle $x^2 + y^2 = 9$, be (h, k) . Then for all possible values of the coordinates of the centre (h, k) , $4(h^2 + k^2)$ is equal to _____.

Ans. (9)

Sol.

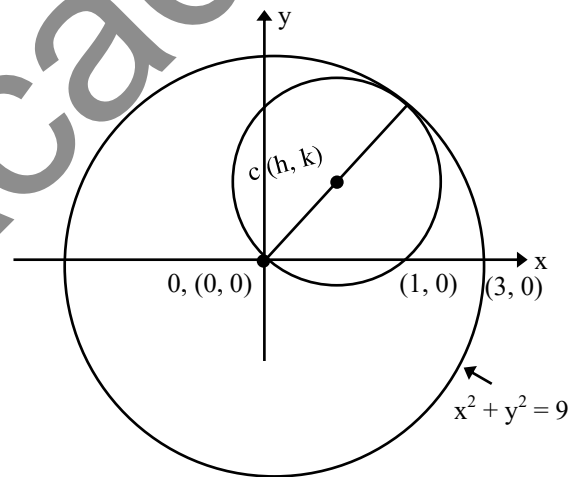

$$(x - h)^2 + (y - k)^2 = h^2 + k^2$$

$$x^2 + y^2 - 2hx - 2ky = 0$$

\therefore passes through $(1, 0)$

$$\Rightarrow 1 + 0 - 2h = 0$$

$$\Rightarrow h = 1/2$$

$$\therefore OC = \frac{OP}{2}$$

$$\sqrt{\left(\frac{1}{2}\right)^2 + k^2} = \frac{3}{2}$$

$$\frac{1}{4} + k^2 = \frac{9}{4}$$

$$k^2 = 2$$

$$k = \pm \sqrt{2}$$

∴ Possible coordinate of

$$c(h, k) \left(\frac{1}{2}, \sqrt{2} \right) \left(\frac{1}{2}, -\sqrt{2} \right)$$

$$4(h^2 + k^2) = 4 \left(\frac{1}{4} + 2 \right) = 4 \left(\frac{9}{4} \right) = 9$$

- 29.** If a function f satisfies $f(m+n) = f(m) + f(n)$ for all $m, n \in \mathbb{N}$ and $f(1) = 1$, then the largest natural number λ such that $\sum_{k=1}^{2022} f(\lambda+k) \leq (2022)^2$ is equal to _____.

Ans. (1010)

Sol. $f(m+n) = f(m) + f(n)$

$$\Rightarrow f(x) = kx$$

$$\Rightarrow f(1) = 1$$

$$\Rightarrow k = 1$$

$$f(x) = x$$

Now

$$\sum_{k=1}^{2022} f(\lambda+k) \leq (2022)^2$$

$$\Rightarrow \sum_{k=1}^{2022} (\lambda+k) \leq (2022)^2$$

$$\Rightarrow 2022\lambda + \frac{2022 \times 2023}{2} \leq (2022)^2$$

$$\Rightarrow \lambda \leq 2022 - \frac{2023}{2}$$

$$\Rightarrow \lambda \leq 1010.5$$

∴ largest natural no. λ is 1010.

- 30.** Let $A = \{2, 3, 6, 7\}$ and $B = \{4, 5, 6, 8\}$. Let R be a relation defined on $A \times B$ by $(a_1, b_1) R (a_2, b_2)$ is and only if $a_1 + a_2 = b_1 + b_2$. Then the number of elements in R is _____.

Ans. (25)

Sol. $A = \{2, 3, 6, 7\}$

$$B = \{2, 5, 6, 8\}$$

$$(a_1, b_1) R (a_2, b_2)$$

$$a_1 + a_2 = b_1 + b_2$$

- | | |
|---------------------|---------------------|
| 1. (2, 4) R (6, 4) | 2. (2, 4) R (7, 5) |
| 3. (2, 5) R (7, 4) | 4. (3, 4) R (6, 5) |
| 5. (3, 5) R (6, 4) | 6. (3, 5) R (7, 5) |
| 7. (3, 6) R (7, 4) | 8. (3, 4) R (7, 6) |
| 9. (6, 5) R (7, 8) | 10. (6, 8) R (7, 5) |
| 11. (7, 8) R (7, 6) | 12. (6, 8) R (6, 4) |
| 13. (6, 6) R (6, 6) | |

× 2

$$\text{Total } 24 + 1 = 25$$

PHYSICS

TEST PAPER WITH SOLUTION

SECTION-A

31. A proton, an electron and an alpha particle have the same energies. Their de-Broglie wavelengths will be compared as:

- (1) $\lambda_e > \lambda_\alpha > \lambda_p$ (2) $\lambda_\alpha < \lambda_p < \lambda_e$
 (3) $\lambda_p < \lambda_e < \lambda_\alpha$ (4) $\lambda_p > \lambda_e > \lambda_\alpha$

Ans. (2)

Sol. $\lambda_{DB} = \frac{h}{p} = \frac{h}{\sqrt{2mk}}$

$\Rightarrow \lambda_{DB} \propto \frac{1}{\sqrt{m}}$

$\Rightarrow \lambda_\alpha < \lambda_p < \lambda_e$

32. A particle moving in a straight line covers half the distance with speed 6 m/s. The other half is covered in two equal time intervals with speeds 9 m/s and 15 m/s respectively. The average speed of the particle during the motion is :

- (1) 8.8 m/s (2) 10 m/s
 (3) 9.2 m/s (4) 8 m/s

Ans. (4)

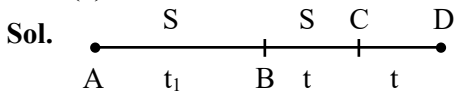

$BD \Rightarrow S = 9t + 15t = 24t$

$AB \Rightarrow S = 6t_1 = 24t \Rightarrow t_1 = 4t$

$\langle \text{speed} \rangle = \frac{\text{dist.}}{\text{time}} = \frac{48t}{2t + t_1}$
 $= \frac{48t}{2t + 4t} = \frac{48t}{6t} \Rightarrow 8 \text{ m/s}$

33. A plane EM wave is propagating along x direction. It has a wavelength of 4 mm. If electric field is in y direction with the maximum magnitude of 60 Vm^{-1} , the equation for magnetic field is:

- (1) $B_z = 60 \sin \left[\frac{\pi}{2} (x - 3 \times 10^8 t) \right] \hat{k} \text{T}$
 (2) $B_z = 2 \times 10^{-7} \sin \left[\frac{\pi}{2} \times 10^3 (x - 3 \times 10^8 t) \right] \hat{k} \text{T}$
 (3) $B_x = 60 \sin \left[\frac{\pi}{2} (x - 3 \times 10^8 t) \right] \hat{i} \text{T}$
 (4) $B_z = 2 \times 10^{-7} \sin \left[\frac{\pi}{2} (x - 3 \times 10^8 t) \right] \hat{k} \text{T}$

Ans. (2)

Sol. $E = BC \Rightarrow 60 = B \times 3 \times 10^8$

$\Rightarrow B = 2 \times 10^{-7}$

Also $C = f\lambda$

$\Rightarrow 3 \times 10^8 = f \times 4 \times 10^{-3}$

$\Rightarrow f = \frac{3}{4} \times 10^{11}$

$\Rightarrow \omega = 2\pi f = \frac{3}{4} \times 2\pi \times 10^{11}$

$\Rightarrow \omega = \frac{\pi}{2} \times 10^3 \text{ C}$

\Rightarrow Electric field \Rightarrow y direction

Propagation \Rightarrow x direction

Magnetic field \Rightarrow z-direction

34. Given below are two statements:

Statement (I): When an object is placed at the centre of curvature of a concave lens, image is formed at the centre of curvature of the lens on the other side.

Statement (II): Concave lens always forms a virtual and erect image.

In the light of the above statements, choose the correct answer from the options given below:

- (1) **Statement I** is false but **Statement II** is true.
 (2) Both **Statement I** and **Statement II** are false.
 (3) **Statement I** is true but **Statement II** is false.
 (4) Both **Statement I** and **Statement II** are true.

NTA Ans. (1)

Allen Ans. (2)

Sol. $\frac{1}{v} - \frac{1}{u} = \frac{1}{f}$

$\frac{1}{v} - \frac{1}{-2f} = \frac{1}{-f}$

$\Rightarrow \frac{1}{v} = \frac{-1}{2f} \Rightarrow v = -2f$

$\frac{1}{v} = \frac{1}{u} + \frac{1}{f} \Rightarrow$ Virtual image of Real object.

In statement II, it is not mentioned that object is real or virtual hence Statement II is false.

35. A light emitting diode (LED) is fabricated using GaAs semiconducting material whose band gap is 1.42 eV. The wavelength of light emitted from the LED is:

- (1) 650 nm (2) 1243 nm
 (3) 875 nm (4) 1400 nm

Ans. (3)

Sol. $\lambda = \frac{1240}{1.42} = 875 \text{ nm (Approx)}$

36. A sphere of relative density σ and diameter D has concentric cavity of diameter d . The ratio of $\frac{D}{d}$, if it just floats on water in a tank is:

- (1) $\left(\frac{\sigma}{\sigma-1}\right)^{\frac{1}{3}}$ (2) $\left(\frac{\sigma+1}{\sigma-1}\right)^{\frac{1}{3}}$
 (3) $\left(\frac{\sigma-1}{\sigma}\right)^{\frac{1}{3}}$ (4) $\left(\frac{\sigma-2}{\sigma+2}\right)^{\frac{1}{3}}$

Ans. (1)

Sol. weight (w) = $\frac{4}{3}\pi\left(\frac{D^3-d^3}{8}\right)\sigma g$

Buoyant force (F_b) = $1 \times \frac{4}{3}\pi\left(\frac{D^3}{8}\right) \cdot g$

For Just Float $\Rightarrow w = F_b$

$\Rightarrow (D^3 - d^3)\sigma = D^3$

$\Rightarrow 1 - \frac{d^3}{D^3} = \frac{1}{\sigma}$

$\Rightarrow 1 - \frac{1}{\sigma} = \left(\frac{d}{D}\right)^3$

$\Rightarrow \left(\frac{\sigma}{\sigma-1}\right)^{\frac{1}{3}} = \left(\frac{D}{d}\right)$

37. A capacitor is made of a flat plate of area A and a second plate having a stair-like structure as shown in figure. If the area of each stair is $\frac{A}{3}$ and the height is d , the capacitance of the arrangement is:

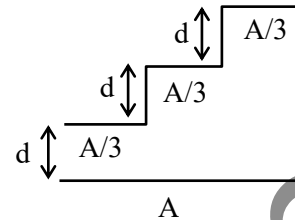

- (1) $\frac{11\epsilon_0 A}{18d}$ (2) $\frac{13\epsilon_0 A}{17d}$
 (3) $\frac{11\epsilon_0 A}{20d}$ (4) $\frac{18\epsilon_0 A}{11d}$

Ans. (1)

Sol. All capacitor are in parallel combination.

Also effective area is common area only

$\Rightarrow C_{eq} = C_1 + C_2 + C_3$

$\Rightarrow C_{eq} = \frac{A\epsilon_0}{3d} + \frac{A\epsilon_0}{3(2d)} + \frac{A\epsilon_0}{3(3d)}$

$\Rightarrow C_{eq} = \frac{A\epsilon_0}{3} \left(\frac{11}{6d}\right)$

$\Rightarrow C_{eq} = \frac{11A\epsilon_0}{18d}$

38. A light unstretchable string passing over a smooth light pulley connects two blocks of masses m_1 and m_2 . If the acceleration of the system is $\frac{g}{8}$, then the

ratio of the masses $\frac{m_2}{m_1}$ is:

- (1) 9 : 7 (2) 4 : 3
 (3) 5 : 3 (4) 8 : 1

Ans. (1)

Sol. $a_{sys} = \left(\frac{m_2 - m_1}{m_1 + m_2}\right)g = \frac{g}{8}$

$\Rightarrow \frac{m_2}{m_1} = \frac{9}{7}$

39. The dimensional formula of latent heat is:

- (1) $[M^0L^2T^{-2}]$ (2) $[MLT^{-2}]$
 (3) $[M^0L^2T^{-2}]$ (4) $[ML^2T^{-2}]$

Ans. (3)

Sol. Latent heat is specific heat

$$\Rightarrow \frac{ML^2T^{-2}}{M} = M^0L^2T^{-2}$$

40. The volume of an ideal gas ($\gamma = 1.5$) is changed adiabatically from 5 litres to 4 litres. The ratio of initial pressure to final pressure is:

- (1) $\frac{4}{5}$ (2) $\frac{16}{25}$
 (3) $\frac{8}{5\sqrt{5}}$ (4) $\frac{2}{\sqrt{5}}$

Ans. (3)

Sol. For Adiabatic process

$$P_i V_i = P_f V_f^\gamma$$

$$P_i (5)^{1.5} = P_f (4)^{1.5}$$

$$\frac{P_i}{P_f} = \left(\frac{4}{5}\right)^{\frac{3}{2}} = \frac{4}{5} \cdot \left(\frac{4}{5}\right)^{\frac{1}{2}} \Rightarrow \frac{8}{5\sqrt{5}}$$

41. The energy equivalent of 1g of substance is:

- (1) 11.2×10^{24} MeV (2) 5.6×10^{12} MeV
 (3) 5.6 eV (4) 5.6×10^{26} MeV

Ans. (4)

Sol. $E = mC^2$

$$\Rightarrow E = (1 \times 10^{-3}) \times (3 \times 10^8)^2 \text{ J}$$

$$\Rightarrow E = (10^{-3}) (9 \times 10^{16}) (6.241 \times 10^{18}) \text{ eV}$$

$$E = 56.169 \times 10^{31} \text{ eV}$$

$$E \approx 5.6 \times 10^{26} \text{ MeV}$$

42. An astronaut takes a ball of mass m from earth to space. He throws the ball into a circular orbit about earth at an altitude of 318.5 km. From earth's surface to the orbit, the change in total mechanical energy of the ball is $x \frac{GM_e m}{21R_e}$. The value of x is

(take $R_e = 6370$ km):

- (1) 11 (2) 9
 (3) 12 (4) 10

Ans. (1)

Sol. $h = 318.5 \approx \left(\frac{R_e}{20}\right)$

$$T \cdot E_i = \frac{-GM_e m}{R_e}$$

$$T \cdot E_f = \frac{-GM_e m}{2(R_e + h)} = \frac{-GM_e m}{2\left(R_e + \frac{R_e}{20}\right)}$$

$$\Rightarrow T \cdot E_f = \frac{-10GM_e m}{21R_e}$$

Change in total mechanical energy

$$= TE_f - TE_i$$

$$= \frac{GM_e m}{Re} \left[1 - \frac{10}{21}\right] = \frac{11GM_e m}{21Re}$$

43. Given below are two statements:

Statement (I) : When currents vary with time, Newton's third law is valid only if momentum carried by the electromagnetic field is taken into account.

Statement (II) : Ampere's circuital law does not depend on Biot-Savart's law.

In the light of the above statements, choose the **correct** answer from the options given below:

- (1) Both **Statement I** and **Statement II** are false.
 (2) **Statement I** is true but **Statement II** is false.
 (3) **Statement I** is false but **Statement II** is true.
 (4) Both **Statement I** and **Statement II** are true.

Ans. (2)

Sol. Conceptual.

44. A particle of mass m moves on a straight line with its velocity increasing with distance according to the equation $v = \alpha\sqrt{x}$, where α is a constant. The total work done by all the forces applied on the particle during its displacement from $x = 0$ to $x = d$, will be:

- (1) $\frac{m}{2\alpha^2 d}$ (2) $\frac{md}{2\alpha^2}$
 (3) $\frac{m\alpha^2 d}{2}$ (4) $2m\alpha^2 d$

Ans. (3)

Sol. $v = \alpha\sqrt{x}$

at $x = 0$: $v = 0$

& at $x = d$; $v = \alpha\sqrt{d}$

W.D = $K_f - K_i$

W.D = $\frac{1}{2}m(\alpha\sqrt{d})^2 - \frac{1}{2}m(0)^2$

\Rightarrow W.D = $\frac{m\alpha^2 d}{2}$

45. A galvanmeter has a coil of resistance 200Ω with a full scale deflection at $20 \mu\text{A}$. The value of resistance to be added to use it as an ammeter of range $(0-20) \text{ mA}$ is:

- (1) 0.40Ω (2) 0.20Ω
 (3) 0.50Ω (4) 0.10Ω

Ans. (2)

Sol. $G = 200 \Omega$

$i_g = 20 \mu\text{A}$

$i = i_g \left(\frac{G}{S} + 1 \right)$

$\Rightarrow 20 \times 10^{-3} = 20 \times 10^{-6} \left(\frac{200}{S} + 1 \right)$

$\Rightarrow \frac{200}{S} = 999$

$\Rightarrow S \approx 0.2 \Omega$

46. A heavy iron bar, of weight W is having its one end on the ground and the other on the shoulder of a person. The bar makes an angle θ with the horizontal. The weight experienced by the person is:

- (1) $\frac{W}{2}$ (2) W
 (3) $W \cos \theta$ (4) $W \sin \theta$

Ans. (1)

Sol.

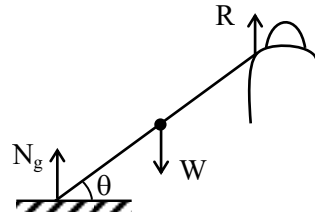

$R =$ net reaction force by shoulder

Balancing torque about pt of contact on ground:

$W \left(\frac{L}{2} \cos \theta \right) = R (L \cos \theta)$

$\Rightarrow R = \frac{W}{2}$

47. One main scale division of a vernier caliper is equal to m units. If n^{th} division of main scale coincides with $(n + 1)^{\text{th}}$ division of vernier scale, the least count of the vernier caliper is:

- (1) $\frac{n}{(n+1)}$ (2) $\frac{m}{(n+1)}$
 (3) $\frac{1}{(n+1)}$ (4) $\frac{m}{n(n+1)}$

Ans. (2)

Sol. $n \text{ MSD} = (n + 1) \text{ VSD}$

$\Rightarrow 1 \text{ VSD} = \frac{n}{n+1} \text{ MSD}$

$L.C = 1 \text{ MSD} - 1 \text{ VSD}$

$L.C = m - m \left(\frac{n}{n+1} \right)$

$L.C = m \left(\frac{n+1-n}{n+1} \right)$

$\Rightarrow L.C = \left(\frac{m}{n+1} \right)$

48. A bulb and a capacitor are connected in series across an ac supply. A dielectric is then placed between the plates of the capacitor. The glow of the bulb:

- (1) increases (2) remains same
 (3) becomes zero (4) decreases

Ans. (1)

Sol.

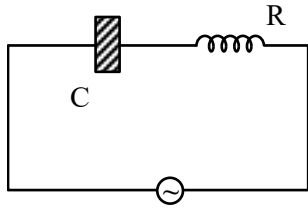

$$Z = \sqrt{R^2 + X_C^2} \quad \& \quad X_C = \frac{1}{\omega C}$$

due to dielectric

$$C \uparrow \Rightarrow X_C \downarrow \Rightarrow Z \downarrow$$

So, current increases & thus bulb will glow more brighter.

49. The equivalent resistance between A and B is:

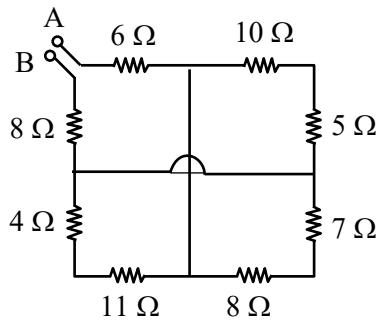

- (1) 18 Ω (2) 25 Ω
 (3) 27 Ω (4) 19 Ω

Ans. (4)

Sol.

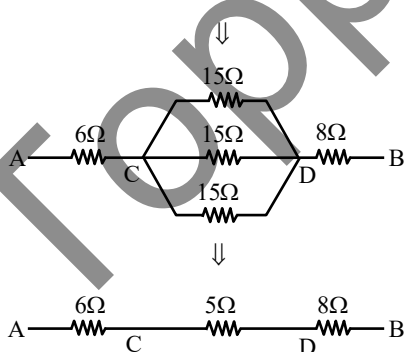
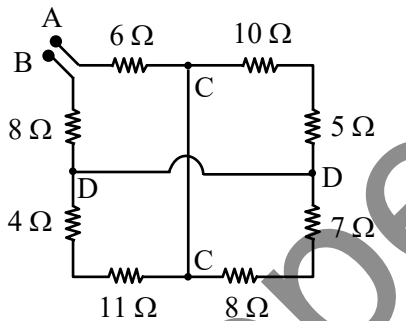

$$\Rightarrow R_{eq} = 6\Omega + 5\Omega + 8\Omega = 19\Omega$$

50. A sample of 1 mole gas at temperature T is adiabatically expanded to double its volume. If adiabatic constant for the gas is $\gamma = \frac{3}{2}$, then the work done by the gas in the process is:

- (1) $RT[2 - \sqrt{2}]$ (2) $\frac{R}{T}[2 - \sqrt{2}]$
 (3) $RT[2 + \sqrt{2}]$ (4) $\frac{T}{R}[2 + \sqrt{2}]$

Ans. (1)

Sol. $TV^{\gamma-1} = \text{constant}$

$$\Rightarrow T(V)^{\frac{3}{2}-1} = T_f(2V)^{\frac{3}{2}-1}$$

$$\Rightarrow TV^{\frac{1}{2}} = T_f(2)^{\frac{1}{2}}(V)^{\frac{1}{2}}$$

$$\Rightarrow T_f = \left(\frac{T}{\sqrt{2}}\right)$$

$$\text{Now, W.D.} = \frac{nR\Delta T}{1-\gamma} = \frac{1 \cdot R \left[\frac{T}{\sqrt{2}} - T \right]}{1 - \frac{3}{2}}$$

$$\Rightarrow \text{W.D.} = 2RT \left[1 - \frac{1}{\sqrt{2}} \right]$$

$$\Rightarrow \text{W.D.} = RT[2 - \sqrt{2}]$$

SECTION-B

51. If \vec{a} and \vec{b} makes an angle $\cos^{-1}\left(\frac{5}{9}\right)$ with each other, then $|\vec{a} + \vec{b}| = \sqrt{2} |\vec{a} - \vec{b}|$ for $|\vec{a}| = n |\vec{b}|$. The integer value of n is _____.

Ans. (3)

Sol. $\cos\theta = \frac{5}{9}$

$$\frac{\vec{a} \cdot \vec{b}}{ab} = \frac{5}{9} \quad \dots\dots(1)$$

$$|\vec{a} + \vec{b}| = \sqrt{2} |\vec{a} - \vec{b}|$$

$$a^2 + b^2 + 2\vec{a} \cdot \vec{b} = 2a^2 + 2b^2 - 4\vec{a} \cdot \vec{b}$$

$$6\vec{a} \cdot \vec{b} = a^2 + b^2$$

$$6 \times \frac{5}{9} ab = a^2 + b^2$$

$$\frac{10}{3} ab = a^2 + b^2 \quad \& \quad a = nb$$

$$\frac{10}{3} nb^2 = n^2 b^2 + b^2$$

$$3n^2 - 10n + 3 = 0$$

$$n = \frac{1}{3} \quad \text{and} \quad n = 3$$

integer value $n = 3$

52. At the centre of a half ring of radius $R = 10$ cm and linear charge density $4n$ C m^{-1} , the potential is $x \pi$ V. The value of x is _____.

Ans. (36)

Sol. Potential at centre of half ring

$$V = \frac{KQ}{R}$$

$$V = \frac{K\lambda\pi R}{R}$$

$$V = K\lambda\pi \Rightarrow V = 9 \times 10^9 \times 4 \times 10^{-9} \pi$$

$$V = 36\pi$$

53. A star has 100% helium composition. It starts to convert three ${}^4\text{He}$ into one ${}^{12}\text{C}$ via triple alpha process as ${}^4\text{He} + {}^4\text{He} + {}^4\text{He} \rightarrow {}^{12}\text{C} + Q$. The mass of the star is 2.0×10^{32} kg and it generates energy at the rate of 5.808×10^{30} W. The rate of converting these ${}^4\text{He}$ to ${}^{12}\text{C}$ is $n \times 10^{42} \text{ s}^{-1}$, where n is _____. [Take, mass of ${}^4\text{He} = 4.0026$ u, mass of ${}^{12}\text{C} = 12$ u]

NTA Ans. (5)

Sol. ${}^4\text{He} + {}^4\text{He} + {}^4\text{He} \rightarrow {}^{12}\text{C} + Q$

$$\text{power generated} = \frac{N}{t} Q$$

where, $N \rightarrow$ No. of reaction/sec.

$$Q = (3m_{\text{He}} - m_{\text{C}}) C^2$$

$$Q = (3 \times 4.0026 - 12) (3 \times 10^8)^2$$

$$Q = 7.266 \text{ MeV}$$

$$\frac{N}{t} = \frac{\text{power}}{Q} = \frac{5.808 \times 10^{30}}{7.266 \times 10^6 \times 1.6 \times 10^{-19}}$$

$$\frac{N}{t} = 5 \times 10^{42}$$

rate of conversion of ${}^4\text{He}$ into ${}^{12}\text{C} = 15 \times 10^{42}$

Hence, $n = 15$

54. In a Young's double slit experiment, the intensity at a point is $\left(\frac{1}{4}\right)^{\text{th}}$ of the maximum intensity, the minimum distance of the point from the central maximum is _____ μm . (Given : $\lambda = 600$ nm, $d = 1.0$ mm, $D = 1.0$ m)

Ans. (200)

$$\text{Sol. } I = I_0 \cos^2\left(\frac{\Delta\phi}{2}\right)$$

$$\frac{I_0}{4} = \cos^2\left(\frac{\Delta\phi}{2}\right)$$

$$\Delta\phi = \frac{2\pi}{3}$$

$$\frac{2\pi}{\lambda} \left(\frac{yd}{D}\right) = \frac{2\pi}{3}$$

$$y = \frac{\lambda D}{3d} = \frac{600 \times 10^{-9} \times 1}{3 \times 10^{-3}} = 2 \times 10^{-4} \text{ m}$$

55. A string is wrapped around the rim of a wheel of moment of inertia 0.40 kgm^2 and radius 10 cm. The wheel is free to rotate about its axis. Initially the wheel is at rest. The string is now pulled by a force of 40 N. The angular velocity of the wheel after 10 s is x rad/s, where x is _____.

Ans. (100)

$$\text{Sol. } \tau = FR = I\alpha \Rightarrow 40 \times 0.1 = 0.4\alpha$$

$$\alpha = 10 \text{ rad/s}^2$$

$$W_f = 10 \times 10 = 100 \text{ rad/s}$$

56. A square loop of edge length 2 m carrying current of 2 A is placed with its edges parallel to the x - y axis. A magnetic field is passing through the x - y plane and expressed as $\vec{B} = B_0(1+4x)\hat{k}$, where $B_0 = 5$ T. The net magnetic force experienced by the loop is _____ N.

Ans. (160)

Sol.

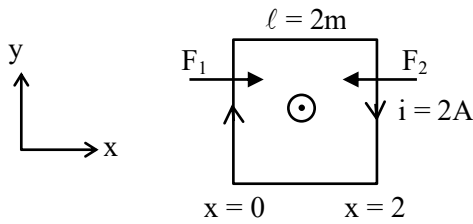

$$B(x=0) = B_0, \quad B(x=2) = 9B_0$$

$$\text{Also, } F = i\ell B$$

$$\Rightarrow F_1 = i\ell B_0 \quad \& \quad F_2 = 9i\ell B_0$$

$$F = F_2 - F_1 = 8i\ell B_0 = 8 \times 2 \times 2 \times 5$$

$$F = 160 \text{ N}$$

57. Two persons pull a wire towards themselves. Each person exerts a force of 200 N on the wire. Young's modulus of the material of wire is $1 \times 10^{11} \text{ N m}^{-2}$. Original length of the wire is 2 m and the area of cross section is 2 cm^2 . The wire will extend in length by _____ μm .

Ans. (20)

Sol.



$$\frac{F}{A} = Y \frac{\Delta \ell}{\ell} \Rightarrow \Delta \ell = \frac{F\ell}{AY}$$

$$\Delta \ell = \frac{200 \times 2}{2 \times 10^{-4} \times 10^{11}} = 2 \times 10^{-5} = 20 \mu\text{m}$$

58. When a coil is connected across a 20 V dc supply, it draws a current of 5 A. When it is connected across 20 V, 50 Hz ac supply, it draws a current of 4 A. The self inductance of the coil is _____ mH. (Take $\pi = 3$)

Ans. (10)

Sol. Case-I:

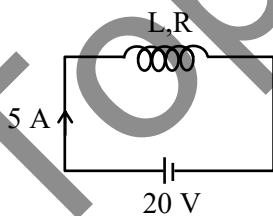

$$i = \frac{20}{R} \Rightarrow R = 4\Omega$$

Case-II:

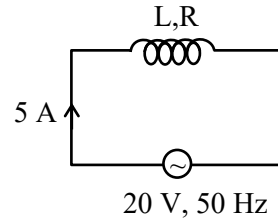

$$i = \frac{20}{Z}$$

$$4 = \frac{20}{\sqrt{R^2 + X_L^2}} \Rightarrow \sqrt{R^2 + X_L^2} = 5$$

$$R^2 + X_L^2 = 25 \Rightarrow X_L = 3\Omega$$

$$L = \frac{3}{2\pi f} = \frac{1}{2 \times 50} = \frac{1000}{100} \text{ mH}$$

$$L = 10 \text{ mH}$$

59. The position, velocity and acceleration of a particle executing simple harmonic motion are found to have magnitudes of 4 m, 2 ms^{-1} and 16 ms^{-2} at a certain instant. The amplitude of the motion is \sqrt{x} m where x is _____.

Ans. (17)

Sol. $x = 4 \text{ m}$, $V = 2 \text{ m/s}$, $a = 16 \text{ m/s}^2$

$$|a| = \omega^2 x$$

$$\Rightarrow 16 = \omega^2(4)$$

$$\omega = 2 \text{ rad/s}$$

$$v = \omega \sqrt{A^2 - x^2}$$

$$A = \sqrt{\frac{v^2}{\omega^2} + x^2} \Rightarrow A = \sqrt{\frac{4}{4} + 16}$$

$$A = \sqrt{17} \text{ m}$$

60. The current flowing through the 1Ω resistor is $\frac{n}{10}$

A. The value of n is _____.

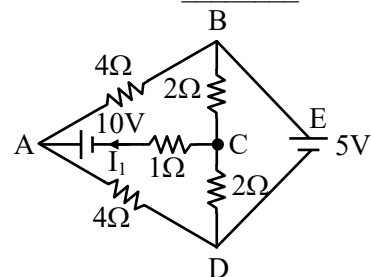

Ans. (25)

Sol.

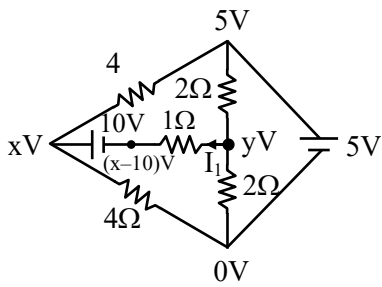

$$\frac{y-5}{2} + \frac{y-0}{2} + \frac{y-x+10}{1} = 0$$

$$y-5+y+2y-2x+20=0$$

$$4y-2x+15=0 \quad \dots(i)$$

$$\frac{x-5}{4} + \frac{x-0}{4} + \frac{x-10-y}{1} = 0$$

$$x-5+x+4x-40-4y=0$$

$$6x-4y-45=0 \quad \dots(ii)$$

$$-2x+4y+15=0 \quad \dots(iii)$$

$$4x-30=0$$

$$x = \frac{15}{2} \quad \& \quad 4y - 15 + 15 = 0$$

$$y = 0$$

$$i = \frac{y-x+10}{1}$$

$$i = \frac{0-7.5+10}{1}$$

$$i = 2.5A = \frac{n}{10}A$$

$$n = 25$$

CHEMISTRY

TEST PAPER WITH SOLUTION

SECTION-A

- 61.** The molar conductivity for electrolytes A and B are plotted against $C^{1/2}$ as shown below. Electrolytes A and B respectively are :

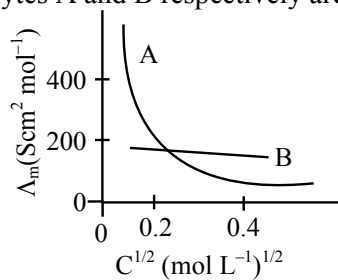

A

B

- | | |
|------------------------|--------------------|
| (1) Weak electrolyte | weak electrolyte |
| (2) Strong electrolyte | strong electrolyte |
| (3) Weak electrolyte | strong electrolyte |
| (4) Strong electrolyte | weak electrolyte |

Ans. (3)

Sol. A → Weak electrolyte
B → Strong electrolyte

- 62.** Methods used for purification of organic compounds are based on :
- (1) neither on nature of compound nor on the impurity present.
 - (2) nature of compound only.
 - (3) nature of compound and presence of impurity.
 - (4) presence of impurity only.

Ans. (3)

Sol. Organic compounds are purified based on their nature and impurity present in it.

- 63.** In the following sequence of reaction, the major products B and C respectively are :

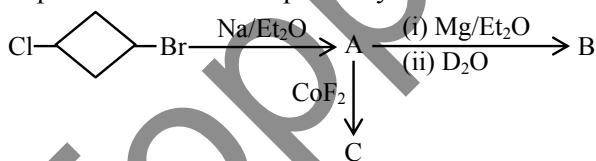

- (1) D-Cyclohexane-D and F-Cyclohexane-F
- (2) D-Cyclohexane-D and F-Cyclohexane-F
- (3) D-Cyclohexane-D and F-Cyclohexane-F
- (4) D-Cyclohexane-D and F-Cyclohexane-F

Ans. (1)

Sol.

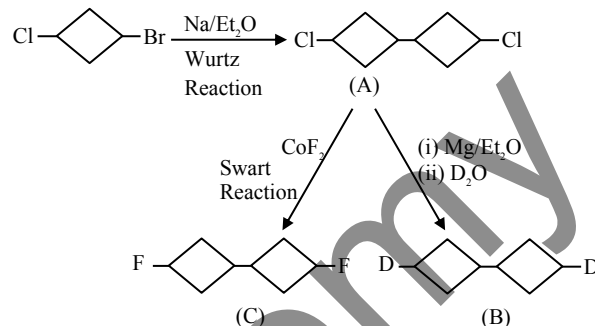

- 64.** Correct order of basic strength of Pyrrole ,

Pyridine and Piperidine is:

- (1) Piperidine > Pyridine > Pyrrole
- (2) Pyrrole > Pyridine > Piperidine
- (3) Pyridine > Piperidine > Pyrrole
- (4) Pyrrole > Piperidine > Pyridine

Ans. (1)

Sol. Order of basic strength is
 $N(sp^3, \text{ localized lone pair}) > N(sp^2, \text{ localized lone pair}) > N(sp^2, \text{ delocalized lone pair, aromatic})$
 \therefore Piperidine > Pyridine > Pyrrole

- 65.** In which one of the following pairs the central atoms exhibit sp^2 hybridization ?

- (1) BF_3 and NO_2^-
- (2) NH_2^- and H_2O
- (3) H_2O and NO_2
- (4) NH_2^- and BF_3

Ans. (1)

Sol. $\text{BF}_3 \rightarrow sp^2$
 $\text{NO}_2^- \rightarrow sp^2$
 $\text{H}_2\text{O} \rightarrow sp^3$
 $\text{NO}_2 \rightarrow sp^2$
 $\text{NH}_2^- \rightarrow sp^3$

66. The F^- ions make the enamel on teeth much harder by converting hydroxyapatite (the enamel on the surface of teeth) into much harder fluoroapatite having the formula.

- (1) $[3Ca_3(PO_4)_2 \cdot CaF_2]$
- (2) $[3Ca_2(PO_4)_2 \cdot Ca(OH)_2]$
- (3) $[3Ca_3(PO_4)_3 \cdot CaF_2]$
- (4) $[3Ca_3(PO_4)_2 \cdot Ca(OH)_2]$

Ans. (1)

Sol. Fluoroapatite $\Rightarrow [3Ca_3(PO_4)_2 \cdot CaF_2]$

67. Relative stability of the contributing structures is :

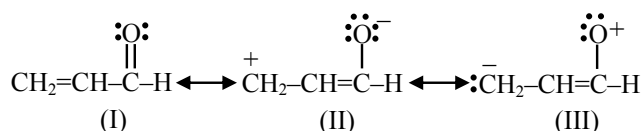

- (1) (I) > (III) > (II)
- (2) (I) > (II) > (III)
- (3) (II) > (I) > (III)
- (4) (III) > (II) > (I)

Ans. (2)

Sol. (1) Neutral structures are more stable than charged ones. Therefore I is more stable than II and III.

(2) +ve charge on less electronegative atom is more stable i.e., C^\oplus is more stable than O^\oplus

\therefore Order is I > II > III

68. Given below are two statements :

Statement (I) : The oxidation state of an element in a particular compound is the charge acquired by its atom on the basis of electron gain enthalpy consideration from other atoms in the molecule.

Statement (II) : $p\pi-p\pi$ bond formation is more prevalent in second period elements over other periods.

In the light of the above statements, choose the **most appropriate** answer from the options given below :

- (1) Both **Statement I** and **Statement II** are incorrect
- (2) **Statement I** is correct but **Statement II** is incorrect
- (3) Both **Statement I** and **Statement II** are correct
- (4) **Statement I** is incorrect but **Statement II** is correct

Ans. (4)

Sol. Oxidation state of an element in a particular compound is defined by the charge acquired by its atom on the basis of electronegativity consideration from other atoms in molecule.

69. Given below are two statements : one is labelled as **Assertion (A)** and the other is labelled as **Reason (R)** :

Assertion (A) : S_N2 reaction of $C_6H_5CH_2Br$ occurs more readily than the S_N2 reaction of CH_3CH_2Br .

Reason (R) : The partially bonded unhybridized p-orbital that develops in the trigonal bipyramidal transition state is stabilized by conjugation with the phenyl ring.

In the light of the above statements, choose the **most appropriate** answer from the options given below :

- (1) (A) is not correct but (R) is correct
- (2) Both (A) and (R) are correct but (R) is not the correct explanation of (A)
- (3) Both (A) and (R) are correct and (R) is the correct explanation of (A)
- (4) (A) is correct but (R) is not correct

Ans. (3)

Sol. The benzyl group acts in much the same way using the π -system of the benzene ring for conjugation with the p-orbital in the transition state.

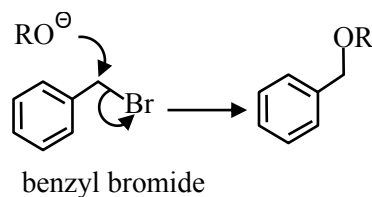

70. For the given compounds, the correct order of increasing pK_a value :

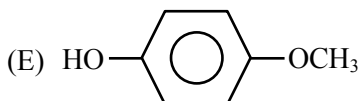
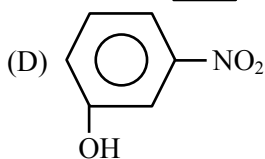
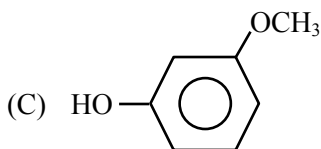
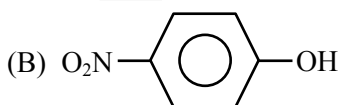
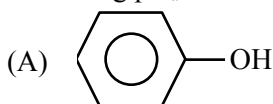

- (1) (E) < (D) < (C) < (B) < (A)
 (2) (D) < (E) < (C) < (B) < (A)
 (3) (E) < (D) < (B) < (A) < (C)
 (4) (B) < (D) < (A) < (C) < (E)

Ans. **BONUS**

NTA Ans. (4)

Sol. Acidic strength order :-

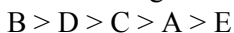

Correct pK_a Order :

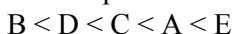

All options are incorrect.

71. Given below are two statements : one is labelled as **Assertion (A)** : and the other is labelled as **Reason (R)**.

Assertion (A) : Both rhombic and monoclinic sulphur exist as S_8 while oxygen exists as O_2 .

Reason (R) : Oxygen forms $p\pi-p\pi$ multiple bonds with itself and other elements having small size and high electronegativity like C, N, which is not possible for sulphur.

In the light of the above statements, choose the **most appropriate** answer from the options given below :

- (1) Both (A) and (R) are correct and (R) is the correct explanation of (A).
 (2) Both (A) and (R) are correct but (R) is not the correct explanation of (A).
 (3) (A) is correct but (R) is not correct.
 (4) (A) is not correct but (R) is correct.

Ans. (3)

Sol. Oxygen can form $2p\pi-2p\pi$ multiple bond with itself due to its small size while sulphur cannot form multiple bond with itself as $3p\pi-3p\pi$ bond will be unstable due to large size of sulphur, but sulphur can form multiple bond with small size atom like C and N.

eg. $S=C=S$

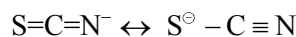

72. Given below are two statements : one is labelled as **Assertion (A)** and the other is labelled as **Reason (R)**.

Assertion (A): The total number of geometrical isomers shown by $[Co(en)_2Cl_2]^+$ complex ion is three

Reason (R): $[Co(en)_2Cl_2]^+$ complex ion has an octahedral geometry.

In the light of the above statements, choose the **most appropriate** answer from the options given below :

- (1) Both (A) and (R) are correct and (R) is the correct explanation of (A).
 (2) (A) is correct but (R) is not correct.
 (3) (A) is not correct but (R) is correct.
 (4) Both (A) and (R) are correct but (R) is not the correct explanation of (A).

Ans. (3)

Sol. $[Co(en)_2Cl_2]^+$ has octahedral geometry with two geometrical isomers.

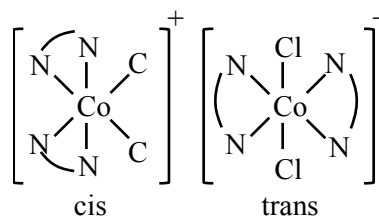

73. The electronic configuration of Cu(II) is $3d^9$ whereas that of Cu(I) is $3d^{10}$. Which of the following is correct ?

- (1) Cu(II) is less stable
 (2) Stability of Cu(I) and Cu(II) depends on nature of copper salts
 (3) Cu(II) is more stable
 (4) Cu(I) and Cu(II) are equally stable

Ans. (3)

Sol. Cu(II) is more stable than Cu(I) because hydration energy of Cu^{+2} ion compensate IE_2 of Cu.

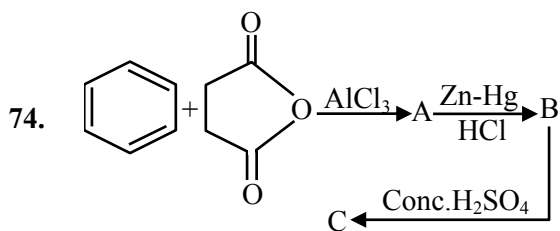

What is the structure of C ?

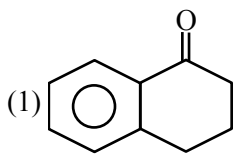
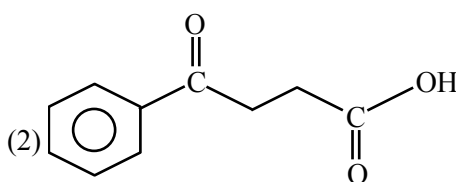
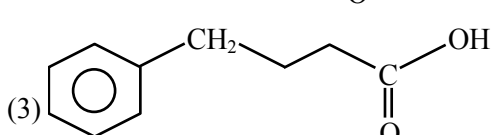
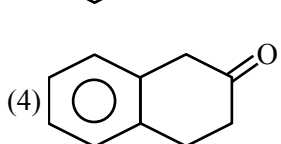
- (1) 
- (2) 
- (3) 
- (4) 

Ans. (1)

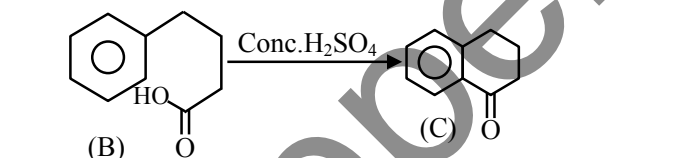
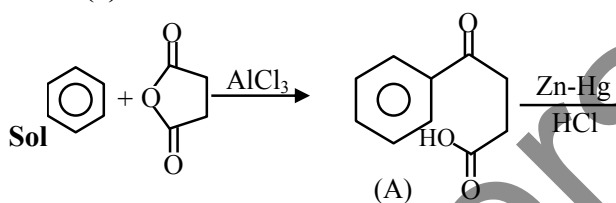

75. Compare the energies of following sets of quantum numbers for multielectron system.

- (A) $n = 4, l = 1$ (B) $n = 4, l = 2$
 (C) $n = 3, l = 1$ (D) $n = 3, l = 2$
 (E) $n = 4, l = 0$

Choose the correct answer from the options given below :

- (1) (B) > (A) > (C) > (E) > (D)
 (2) (E) > (C) < (D) < (A) < (B)
 (3) (E) > (C) > (A) > (D) > (B)
 (4) (C) < (E) < (D) < (A) < (B)

Ans. (4)

Sol. Energy level can be determined by comparing $(n + l)$ values

- (A) $n = 4, l = 1 \Rightarrow (n + l) = 5$
 (B) $n = 4, l = 2 \Rightarrow (n + l) = 6$
 (C) $n = 3, l = 1 \Rightarrow (n + l) = 4$
 (D) $n = 3, l = 2 \Rightarrow (n + l) = 5$
 (E) $n = 4, l = 0 \Rightarrow (n + l) = 4$

For same value of $(n + l)$, orbital having higher value of n , will have more energy.
 (B) > (A) > (D) > (E) > (C)

76. Identify major product "X" formed in the following reaction :

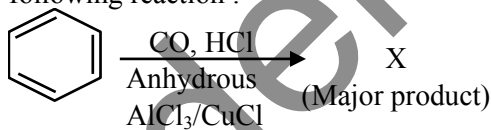

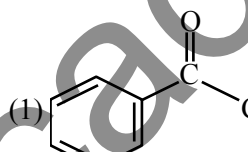
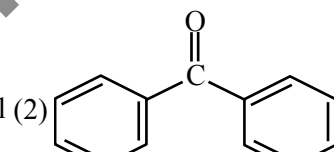
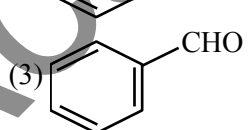
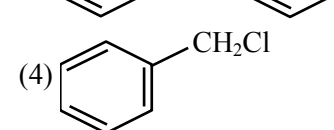
- (1) 
- (2) 
- (3) 
- (4) 

Ans. (3)

Sol. This is Gattermann-Koch reaction

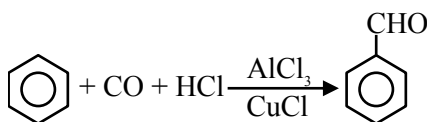

77. Identify the product A and product B in the following set of reactions.

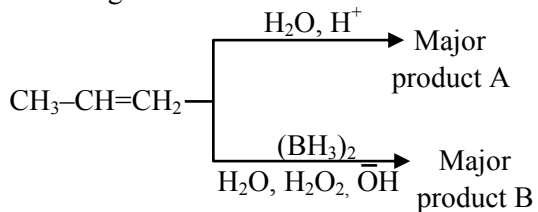

- (1) A- $\text{CH}_3\text{CH}_2\text{CH}_2\text{-OH}$, B- $\text{CH}_3\text{CH}_2\text{CH}_2\text{-OH}$
 (2) A- $\text{CH}_3\text{CH}_2\text{CH}_2\text{-OH}$, B- $\text{CH}_3\text{CH}(\text{OH})\text{-CH}_3$
 (3) A- $\text{CH}_3\text{-CH}(\text{OH})\text{-CH}_3$, B- $\text{CH}_3\text{CH}_2\text{CH}_2\text{-OH}$
 (4) A- $\text{CH}_3\text{CH}_2\text{CH}_3$, B- $\text{CH}_3\text{CH}_2\text{CH}_3$

Ans. (3)

Sol. (1) Hydration Reaction :

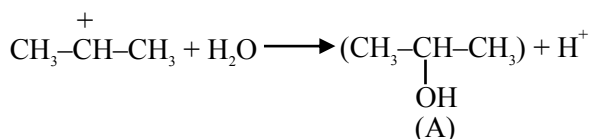
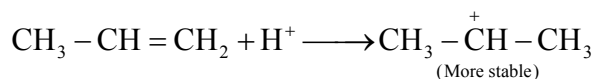

(2) Hydroboration Oxidation Reaction :

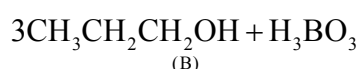
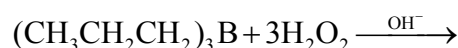
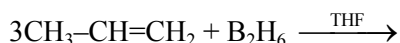

78. On reaction of Lead Sulphide with dilute nitric acid which of the following is **not** formed ?

- (1) Lead nitrate (2) Sulphur
(3) Nitric oxide (4) Nitrous oxide

Ans. (4)

Sol. $\text{PbS} + \text{HNO}_3 \rightarrow \text{Pb}(\text{NO}_3)_2 + \text{NO} + \text{S} + \text{H}_2\text{O}$

Nitrous oxide (N_2O) is not formed during the reaction.

79. Identify the **incorrect** statements regarding primary standard of titrimetric analysis

- (A) It should be purely available in dry form.
(B) It should not undergo chemical change in air.
(C) It should be hygroscopic and should react with another chemical instantaneously and stoichiometrically.
(D) It should be readily soluble in water.
(E) KMnO_4 & NaOH can be used as primary standard.

Choose the **correct** answer from the options given below :

- (1) (C) and (D) only (2) (B) and (E) only
(3) (A) and (B) only (4) (C) and (E) only

Ans. (4)

Sol. KMnO_4 & $\text{NaOH} \rightarrow$ Secondary standard.

Primary standard should not be Hygroscopic.

80. 0.05M CuSO_4 when treated with 0.01M $\text{K}_2\text{Cr}_2\text{O}_7$ gives green colour solution of $\text{Cu}_2\text{Cr}_2\text{O}_7$. The [SPM : Semi Permeable Membrane]

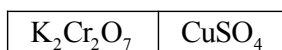

Side X SPM Side Y

Due to osmosis :

- (1) Green colour formation observed on side Y.
(2) Green colour formation observed on side X.
(3) Molarity of $\text{K}_2\text{Cr}_2\text{O}_7$ solution is lowered.
(4) Molarity of CuSO_4 solution is lowered.

Ans. (4)

Sol. Only solvent Molecules are allowed to pass through the SPM.

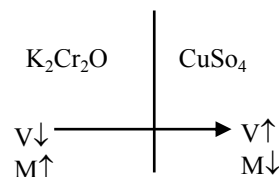

SECTION-B

81. The heat of solution of anhydrous CuSO_4 and $\text{CuSO}_4 \cdot 5\text{H}_2\text{O}$ are -70 kJ mol^{-1} and $+12 \text{ kJ mol}^{-1}$ respectively.

The heat of hydration of CuSO_4 to $\text{CuSO}_4 \cdot 5\text{H}_2\text{O}$ is $-x \text{ kJ}$. The value of x is _____.

Ans. (82)

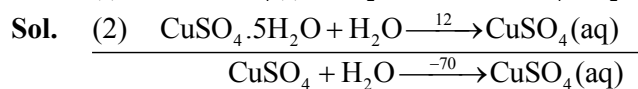
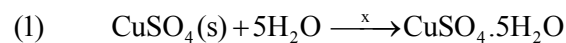

from (1) & (2)

$$-70 = x + 12$$

$$x = -82$$

82. Given below are two statements :

Statement I : The rate law for the reaction $A + B \rightarrow C$ is rate $(r) = k[A]^2[B]$. When the concentration of both A and B is doubled, the reaction rate is increased "x" times.

Statement II :

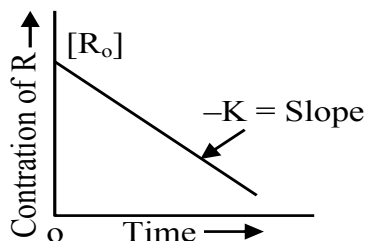

The figure is showing "the variation in concentration against time plot" for a "y" order reaction.

The value of x + y is _____.

Ans. (8)

Sol. $r = K[A]^2[B]$
if conc. are doubled
 $r' = K[2A]^2[2B]^1$
 $r' = 8r \Rightarrow x = 8$

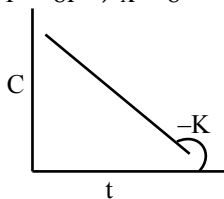

\Rightarrow Zero order, $y = 0$
 $x + y = 8$

83. How many compounds among the following compounds show inductive, mesomeric as well as hyperconjugation effects?

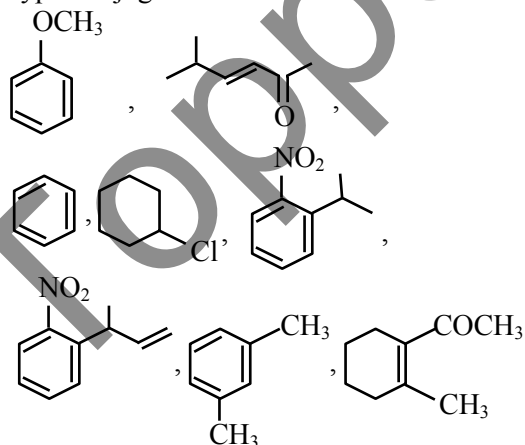

Ans. (4)

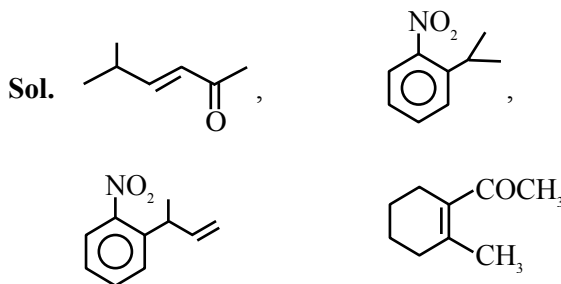

84. The standard reduction potentials at 298 K for the following half cells are given below :

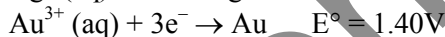
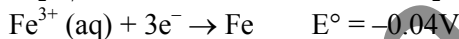
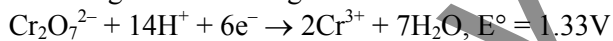

Consider the given electrochemical reactions, The number of metal(s) which will be oxidized by $\text{Cr}_2\text{O}_7^{2-}$, in aqueous solution is _____.

Ans. (3)

Sol. Fe, Ni, Ag will be oxidized due to lower S.R.P.

85. When equal volume of 1M HCl and 1M H_2SO_4 are separately neutralised by excess volume of 1M NaOH solution. X and y kJ of heat is liberated respectively. The value of y/x is _____.

Ans. (2)

Sol. $\text{H}^+ + \text{OH}^- \rightarrow \text{H}_2\text{O} \Rightarrow x$
 $2\text{H}^+ + 2\text{OH}^- \rightarrow 2\text{H}_2\text{O} \Rightarrow 2x = y$
 $y/x = 2$

86. Molarity (M) of an aqueous solution containing x g of anhyd. CuSO_4 in 500 mL solution at 32°C is 2×10^{-1} M. Its molality will be _____ $\times 10^{-3}$ m. (nearest integer).

[Given density of the solution = 1.25 g/mL.]

NTA Ans. (81) BONUS

Sol.

$$M_{\text{sol}^n} = v_{\text{sol}^n} \times d_{\text{sol}^n}$$

$$= 500 \times 1.25 = 625\text{g}$$

$$\text{Mass of solute (x)} = 0.2 \times 0.5 \times 159.5$$

$$= 15.95$$

$$n_{\text{solute}} = 0.1,$$

$$\text{Mass of solvent} = \text{Mass of solution} - \text{Mass of solute}$$

$$= 625 - 15.95$$

$$= 609.05$$

$$m = \frac{0.1}{\frac{609.05}{1000}}$$

$$m = 0.164 = 164 \times 10^{-3}$$

87. The total number of species from the following in which one unpaired electron is present, is _____.

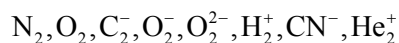

Ans. (4)

Sol. One unpaired e^- is present in : C_2^- ; O_2^- ; H_2^+ ; He_2^+

88. Number of ambidentate ligands among the following is _____.

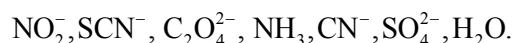

Ans. (3)

Sol. Ligands which have two different donor sites but at a time connects with only one donor site to central metal are ambidentate ligands.

Ambidentate ligands are NO_2^- ; SCN^- ; CN^-

89. Total number of essential amino acid among the given list of amino acids is _____.
Arginine, Phenylalanine, Aspartic acid, Cysteine, Histidine, Valine, Proline

Ans. (4)

Sol. Essential Amino acids are :-

Arginine, Phenylalanine, Histidine, Valine

90. Number of colourless lanthanoid ions among the following is _____.

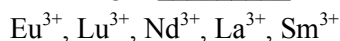

Ans. (2)

Sol. $\text{La}^{3+} - [\text{Xe}]4f^0$

$\text{Nd}^{3+} - [\text{Xe}]4f^3$

$\text{Sm}^{3+} - [\text{Xe}]4f^5$

$\text{Eu}^{3+} - [\text{Xe}]4f^6$

$\text{Lu}^{3+} - [\text{Xe}]4f^{14}$

La^{3+} and Lu^{3+} do not show any colour because no unpaired electron is present.

$$\frac{dy}{\sqrt{1-y^2}} = dx \quad \text{OR} \quad \frac{dy}{\sqrt{1-y^2}} = -dx$$

$$\Rightarrow \sin^{-1}y = x + c, \sin^{-1}y = -x + c$$

$$x = 0, y = 0 \Rightarrow c = 0$$

$$\sin^{-1}y = x, \text{ as } y \geq 0$$

$$\sin x = y$$

$$\Rightarrow \frac{dy}{dx} = \cos x$$

$$\frac{d^2y}{dx^2} = -\sin x$$

$$\Rightarrow -\sin x + \sin x + 1 = 1$$

4. Let z be a complex number such that the real part

of $\frac{z-2i}{z+2i}$ is zero. Then, the maximum value of

$|z-(6+8i)|$ is equal to :

(1) 12 (2) ∞

(3) 10 (4) 8

Ans. (1)

Sol. $\frac{z-2i}{z+2i} + \frac{\bar{z}+2i}{\bar{z}-2i} = 0$

$$z\bar{z} - 2i\bar{z} - 2iz + 4(-1)$$

$$+z\bar{z} + 2zi + 2\bar{z}i + 4(-1) = 0$$

$$\Rightarrow 2|z|^2 = 8 \Rightarrow |z| = 2$$

$$|z-(6+8i)|_{\text{maximum}} = 10 + 2 = 12$$

5. The area (in square units) of the region enclosed by the ellipse $x^2 + 3y^2 = 18$ in the first quadrant below the line $y = x$ is :

(1) $\sqrt{3}\pi + \frac{3}{4}$ (2) $\sqrt{3}\pi$

(3) $\sqrt{3}\pi - \frac{3}{4}$ (4) $\sqrt{3}\pi + 1$

Ans. (2)

Sol. $\frac{x^2}{18} + \frac{y^2}{6} = 1$

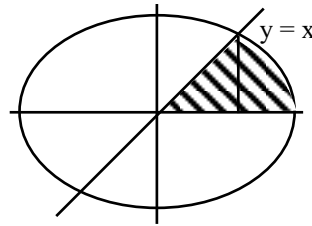

$$\frac{x^2}{18} + \frac{3x^2}{18} = 1 \Rightarrow 4x^2 = 18 \Rightarrow x^2 = \frac{9}{2}$$

$$\int_{\frac{3}{\sqrt{2}}}^{\sqrt{3}} \frac{\sqrt{18-x^2}}{\sqrt{3}} dx$$

$$= \frac{1}{\sqrt{3}} \left(\frac{x\sqrt{18-x^2}}{2} + \frac{18}{2} \sin^{-1} \frac{x}{3\sqrt{2}} \right)_{\frac{3}{\sqrt{2}}}^{\sqrt{3}}$$

$$= \frac{1}{\sqrt{3}} \left(9 \times \frac{\pi}{2} - \frac{3}{2\sqrt{2}} \times \frac{3\sqrt{3}}{\sqrt{2}} - 9 \times \frac{\pi}{6} \right)$$

Required Area

$$= \frac{1}{2} \times \frac{9}{2} + \left(\frac{18\pi}{6} - \frac{9\sqrt{3}}{4} \right) \frac{1}{\sqrt{3}}$$

$$= \sqrt{3}\pi$$

6. Let the foci of a hyperbola H coincide with the foci

of the ellipse $E : \frac{(x-1)^2}{100} + \frac{(y-1)^2}{75} = 1$ and the

eccentricity of the hyperbola H be the reciprocal of

the eccentricity of the ellipse E . If the length of the

transverse axis of H is α and the length of its

conjugate axis is β , then $3\alpha^2 + 2\beta^2$ is equal to :

(1) 242

(2) 225

(3) 237

(4) 205

Ans. (2)

Sol.

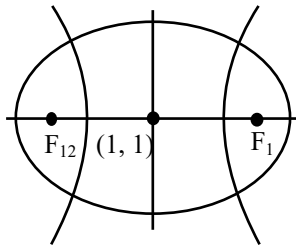

$$e_1 = \sqrt{1 - \frac{75}{100}} = \frac{5}{10} = \frac{1}{2}$$

$$e_2 = 2$$

$$F_1(6, 1), F_2(-4, 1)$$

$$2ae_2 = 10 \Rightarrow a = \frac{5}{2} \Rightarrow 2a = 5$$

$$\Rightarrow \alpha = 5$$

$$4 = 1 + \frac{b^2}{a^2} \Rightarrow b^2 = 3a^2$$

$$b = \sqrt{3} \times \frac{5}{2}$$

$$\beta = 5\sqrt{3}$$

$$3\alpha^2 + 2\beta^2 = 3 \times 25 + 2 \times 25 \times 3 = 225$$

7. Two vertices of a triangle ABC are A(3, -1) and B(-2, 3), and its orthocentre is P(1, 1). If the coordinates of the point C are (α , β) and the centre of the circle circumscribing the triangle PAB is (h, k), then the value of ($\alpha + \beta$) + 2(h + k) equals :

- (1) 51 (2) 81
(3) 5 (4) 15

Ans. (3)

Sol.

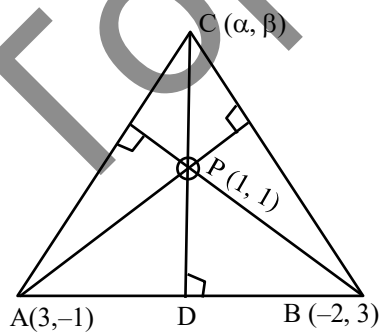

$$M_{AB} = \frac{4}{-5} \Rightarrow M_{DP} = \frac{5}{4}$$

$$\text{Equation of PC is } y - 1 = \frac{5}{4}(x - 1) \dots\dots(1)$$

$$M_{AP} = \frac{2}{-2} = -1 \Rightarrow M_{BC} = +1$$

$$\text{Equation of BC is } y - 3 = (x + 2) \dots\dots(2)$$

On solving (1) and (2)

$$x + 4 = \frac{5}{4}(x - 1) \Rightarrow 4x + 16 = 5x - 5 \Rightarrow \alpha = 21$$

$$\Rightarrow \beta = y = x + 5 = 26$$

$$\alpha + \beta = 47$$

Equation of \perp bisector of AP

$$y - 0 = (x - 2) \dots\dots(3)$$

Equation of \perp bisector of AB

$$y - 1 = \frac{5}{4}\left(x - \frac{1}{2}\right) \dots\dots(4)$$

On solving (3) & (4)

$$(x - 3)4 = 5x - \frac{5}{2}$$

$$x = \frac{-19}{2} = h$$

$$y = \frac{-23}{2} = k$$

$$\Rightarrow 2(h + k) = -42$$

8. If the variance of the frequency distribution is 160, then the value of $c \in \mathbb{N}$ is

x	c	2c	3c	4c	5c	6c
f	2	1	1	1	1	1

$$(1) 5 \qquad (2) 8$$

$$(3) 7 \qquad (4) 6$$

Ans. (3)

Sol.

x	C	2C	3C	4C	5C	6C
f	2	1	1	1	1	1

$$\bar{x} = \frac{(2+2+3+4+5+6)C}{7} = \frac{22C}{7}$$

$$\text{Var}(x) = \frac{c^2(2+2^2+3^2+4^2+5^2+6^2)}{7}$$

$$- \left(\frac{22c}{7} \right)^2$$

$$= \frac{92c^2}{7} - c^2 \times \frac{484}{49}$$

$$= \frac{(644 - 484)c^2}{49} = \frac{160c^2}{49}$$

$$160 = \frac{160 \times c^2}{49} \Rightarrow c = 7$$

9. Let the range of the function

$$f(x) = \frac{1}{2 + \sin 3x + \cos 3x}, x \in \mathbb{R} \text{ be } [a, b].$$

If α and β are respectively the A.M. and the G.M.

of a and b , then $\frac{\alpha}{\beta}$ is equal to :

(1) $\sqrt{2}$ (2) 2

(3) $\sqrt{\pi}$ (4) π

Ans. (1)

Sol. $f(x) = \frac{1}{2 + \sin 3x + \cos 3x}$

$$\left[\frac{1}{2 + \sqrt{2}}, \frac{1}{2 - \sqrt{2}} \right]$$

$$\frac{\alpha}{\beta} = \frac{a+b}{2\sqrt{ab}} = \frac{1}{2} \left(\sqrt{\frac{a}{b}} + \sqrt{\frac{b}{a}} \right)$$

$$= \frac{1}{2} \left(\sqrt{\frac{2-\sqrt{2}}{2+\sqrt{2}}} + \sqrt{\frac{2+\sqrt{2}}{2-\sqrt{2}}} \right)$$

$$= \frac{(2-\sqrt{2}) + (2+\sqrt{2})}{2 \times \sqrt{2}} = \sqrt{2}$$

10. Between the following two statements :

Statement-I : Let $\vec{a} = \hat{i} + 2\hat{j} - 3\hat{k}$ and

$\vec{b} = 2\hat{i} + \hat{j} - \hat{k}$. Then the vector \vec{r} satisfying

$\vec{a} \times \vec{r} = \vec{a} \times \vec{b}$ and $\vec{a} \cdot \vec{r} = 0$ is of magnitude $\sqrt{10}$.

Statement-II : In a triangle ABC, $\cos 2A + \cos 2B$
 $+ \cos 2C \geq -\frac{3}{2}$.

(1) Both Statement-I and Statement-II are incorrect

(2) Statement-I is incorrect but Statement-II is correct

(3) Both Statement-I and Statement-II are correct

(4) Statement-I is correct but Statement-II is incorrect

Ans. (2)

Sol. $\vec{a} = \hat{i} + 2\hat{j} - 3\hat{k}$

$$\vec{a} = 2\hat{i} + \hat{j} - \hat{k}$$

$$\vec{a} \times \vec{r} = \vec{a} \times \vec{b}; \vec{a} \cdot \vec{r} = 0$$

$$\Rightarrow \vec{a} \times (\vec{r} - \vec{b}) = \vec{0}$$

$$\Rightarrow \vec{a} = \lambda(\vec{r} - \vec{b})$$

$$\vec{a} \cdot \vec{a} = \lambda(\vec{a} \cdot \vec{r} - \vec{a} \cdot \vec{b})$$

$$14 = -7\lambda \Rightarrow \lambda = -2$$

$$\frac{-\vec{a}}{2} = \vec{r} - \vec{b} \Rightarrow \vec{r} = \vec{b} - \frac{\vec{a}}{2}$$

$$= \frac{2\vec{b} - \vec{a}}{2} = \frac{3\hat{i} + \hat{k}}{2}$$

Statement (I) is incorrect

$$\cos 2A + \cos 2B + \cos 2C \geq -\frac{3}{2}$$

$$2A + 2B + 2C = 2\pi$$

$$\cos 2A + \cos 2B + \cos 2C$$

$$= -1 - 4 \cos A \cdot \cos B \cdot \cos C$$

$$\geq -1 - 4 \times \frac{1}{2} \times \frac{1}{2} \times \frac{1}{2}$$

$$= -\frac{3}{2}$$

Statement (II) is correct.

11. $\lim_{x \rightarrow \frac{\pi}{2}} \left(\frac{\int_{x^3}^{(\pi/2)^3} (\sin(2t^{1/3}) + \cos(t^{1/3})) dt}{\left(x - \frac{\pi}{2}\right)^2} \right)$ is equal

to :

- (1) $\frac{9\pi^2}{8}$ (2) $\frac{11\pi^2}{10}$
 (3) $\frac{3\pi^2}{2}$ (4) $\frac{5\pi^2}{9}$

Ans. (1)

Sol. $\lim_{x \rightarrow \frac{\pi}{2}} \frac{0 - \{\sin(2x) + \cos(x)\} \cdot 3x^2}{2\left(x - \frac{\pi}{2}\right)}$

$$= \lim_{x \rightarrow \frac{\pi}{2}} \frac{-\{2 \sin x \cos x + \cos x\} 3x^2}{2\left(x - \frac{\pi}{2}\right)}$$

$$= \lim_{x \rightarrow \frac{\pi}{2}} \left\{ \frac{2 \sin x \sin\left(\frac{\pi}{2} - x\right)}{2\left(x - \frac{\pi}{2}\right)} + \frac{\sin\left(\frac{\pi}{2} - x\right)}{2\left(\frac{\pi}{2} - x\right)} \right\} 3x^2$$

$$= \left(1(1) + \frac{1}{2}\right) 3\left(\frac{\pi}{2}\right)^2$$

$$= \frac{9\pi^2}{8}$$

12. The sum of the coefficient of $x^{2/3}$ and $x^{-2/5}$ in the binomial expansion of $\left(x^{2/3} + \frac{1}{2}x^{-2/5}\right)^9$ is :

- (1) 21/4 (2) 69/16
 (3) 63/16 (4) 19/4

Ans. (1)

Sol. $T_{r+1} = {}^9C_r (x^{2/3})^{9-r} \left(\frac{x^{-2/5}}{2}\right)^r$

$$= {}^9C_r \left(\frac{1}{2}\right)^r (r)^{\left(\frac{6-2r}{3} - \frac{2r}{5}\right)}$$

for coefficient of $x^{2/3}$, put $6 - \frac{2r}{3} - \frac{2r}{5} = \frac{2}{3}$

$\Rightarrow r = 5$

\therefore Coefficient of $x^{2/3}$ is ${}^9C_5 \left(\frac{1}{5}\right)^5$

For coefficient of $x^{-2/5}$, put $6 - \frac{2r}{3} - \frac{2r}{5} = \frac{2}{5}$

$\Rightarrow r = 6$

Coefficient of $x^{-2/5}$ is ${}^9C_6 \left(\frac{1}{2}\right)^6$

Sum $= {}^9C_5 \left(\frac{1}{2}\right)^5 + {}^9C_6 \left(\frac{1}{2}\right)^6 = \frac{21}{4}$

13. Let $B = \begin{bmatrix} 1 & 3 \\ 1 & 5 \end{bmatrix}$ and A be a 2×2 matrix such that

$AB^{-1} = A^{-1}$. If $BCB^{-1} = A$ and $C^4 + \alpha C^2 + \beta I = O$, then $2\beta - \alpha$ is equal to :

- (1) 16 (2) 2
 (3) 8 (4) 10

Ans. (4)

Sol. $BCB^{-1} = A$

$\Rightarrow (BCB^{-1})(BCB^{-1}) = A.A$

$\Rightarrow BCB^{-1} = A^2$

$\Rightarrow BC^2B^{-1} = A^2$

$\Rightarrow B^{-1}(BC^2B^{-1})B = B^{-1}(A.A)B$

From equation (1)

$C^2 = A^{-1}.A.B$

$C^2 = B$

Also $AB^{-1} = A^{-1}$

$\Rightarrow AB^{-1}.A = A^{-1}.A = I$

$\Rightarrow A^{-1}(AB^{-1}A) = A^{-1}.I$

$B^{-1}A = A^{-1}$

Now characteristics equation of C^2 is

$|C^2 - \lambda I| = 0$

$|B - \lambda I| = 0$

$$\Rightarrow \begin{vmatrix} 1-\lambda & 3 \\ 1 & 5-\lambda \end{vmatrix} = 0$$

$$\Rightarrow (1-\lambda)(5-\lambda) - 3 = 0 \Rightarrow (\lambda^2 - 6\lambda + 5) - 3 = 0$$

$$\Rightarrow \lambda^2 - 6\lambda + 2 = 0$$

$$\Rightarrow \beta^2 - 6\beta + 2 = 0$$

$$\Rightarrow C^4 - 6C^2 + 2I = 0$$

$$\alpha = -6$$

$$\beta = 2$$

$$\therefore 2\beta - \alpha = 4 + 6 = 10$$

14. If $\log_e y = 3 \sin^{-1} x$, then $(1-x)^2 y'' - xy'$ at $x = \frac{1}{2}$

is equal to :

(1) $9e^{\pi/6}$

(2) $3e^{\pi/6}$

(3) $3e^{\pi/2}$

(4) $9e^{\pi/2}$

Ans. (4)

Sol. $\ln(y) = 3 \sin^{-1} x$

$$\frac{1}{y} \cdot y' = 3 \left(\frac{1}{\sqrt{1-x^2}} \right)$$

$$\Rightarrow y' = \frac{3y}{\sqrt{1-x^2}} \text{ at } x = \frac{1}{2}$$

$$\Rightarrow y' = \frac{3e^{3\left(\frac{\pi}{6}\right)}}{\frac{\sqrt{3}}{2}} = 2\sqrt{3}e^{\frac{\pi}{2}}$$

$$\Rightarrow y'' = 3 \left(\frac{\sqrt{1-x^2} y' - y \frac{1}{2\sqrt{1-x^2}} (-2x)}{(1-x^2)} \right)$$

$$\Rightarrow (1-x^2)y'' = 3 \left(3y + \frac{xy}{\sqrt{1-x^2}} \right)$$

$$\downarrow \text{ at } x = \frac{1}{2}, y = e^{3\sin^{-1}\left(\frac{1}{2}\right)} = e^{3\left(\frac{\pi}{6}\right)} = e^{\frac{\pi}{2}}$$

$$(1-x^2)y'' \Big|_{\text{at } x=\frac{1}{2}} = 3 \left(3e^{\frac{\pi}{2}} + \frac{\frac{1}{2} \left(e^{\frac{\pi}{2}} \right)}{\frac{\sqrt{3}}{2}} \right)$$

$$= 3e^{\frac{\pi}{2}} \left(3 + \frac{1}{\sqrt{3}} \right)$$

$$(1-x^2)y'' - xy' \Big|_{\text{at } x=\frac{1}{2}}$$

$$= 3e^{\frac{\pi}{2}} \left(3 + \frac{1}{\sqrt{3}} \right) - \frac{1}{2} \left(2\sqrt{3}e^{\frac{\pi}{2}} \right) = 9e^{\frac{\pi}{2}}$$

15. The integral $\int_{1/4}^{3/4} \cos \left(2 \cot^{-1} \sqrt{\frac{1-x}{1+x}} \right) dx$ is equal

to:

(1) $-1/2$

(2) $1/4$

(3) $1/2$

(4) $-1/4$

Ans. (4)

Sol. $I = \int_{1/4}^{3/4} \cos \left(2 \cot^{-1} \left(\sqrt{\frac{1-x}{1+x}} \right) dx \right)$

$$\int_{1/4}^{3/4} \cos \left(2 \left(\tan^{-1} \sqrt{\frac{1+x}{1-x}} \right) \right) dx$$

$$\int_{1/4}^{3/4} \frac{1 - \tan^2 \left(\tan^{-1} \sqrt{\frac{1+x}{1-x}} \right)}{1 + \tan^2 \left(\tan^{-1} \sqrt{\frac{1+x}{1-x}} \right)} dx$$

$$= \int_{1/4}^{3/4} \frac{1 - \left(\frac{1+x}{1-x} \right)}{1 + \left(\frac{1+x}{1-x} \right)} dx = \int_{1/4}^{3/4} \frac{-2x}{2} dx$$

$$= \int_{1/4}^{3/4} (-x) dx = - \left(\frac{x^2}{2} \right)_{1/4}^{3/4}$$

$$= - \frac{1}{2} \left[\frac{9}{16} - \frac{1}{16} \right]$$

$$= - \frac{1}{4}$$

16. Let a, ar, ar^2, \dots be an infinite G.P. If

$$\sum_{n=0}^{\infty} ar^n = 57 \text{ and } \sum_{n=0}^{\infty} a^3 r^{3n} = 9747, \text{ then } a + 18r \text{ is}$$

equal to :

(1) 27 (2) 46

(3) 38 (4) 31

Ans. (4)

Sol. $\sum_{n=0}^{\infty} ar^n = 57$

$$a + ar + ar^2 + \dots = 57$$

$$\frac{a}{1-r} = 57 \dots\dots\dots (I)$$

$$\sum_{n=0}^{\infty} a^3 r^{3n} = 9747$$

$$a^3 + a^3 \cdot r^3 + a^3 \cdot r^6 + \dots = 9747$$

$$\frac{a^3}{1-r^3} = 9747 \dots\dots\dots (II)$$

$$\frac{(I)^3}{(II)} \Rightarrow \frac{(1-r)^3}{a^3} = \frac{57^3}{9747} = 19$$

On solving, $r = \frac{2}{3}$ and $r = \frac{3}{2}$ (rejected)

$$a = 19$$

$$\therefore a + 18r = 19 + 18 \times \frac{2}{3} = 31$$

17. If an unbiased dice is rolled thrice, then the probability of getting a greater number in the i^{th} roll than the number obtained in the $(i-1)^{\text{th}}$ roll, $i = 2, 3$, is equal to :

(1) 3/54 (2) 2/54

(3) 5/54 (4) 1/54

Ans. (3)

Sol. Favourable cases = 6C_3

$$\text{Total outcomes} = 6^3$$

Probability of getting greater number than previous

$$\text{one} = \frac{{}^6C_3}{6^3} = \frac{20}{216} = \frac{5}{54}$$

18. The value of the integral $\int_{-1}^2 \log_e (x + \sqrt{x^2 + 1}) dx$

is :

(1) $\sqrt{5} - \sqrt{2} + \log_e \left(\frac{9+4\sqrt{5}}{1+\sqrt{2}} \right)$

(2) $\sqrt{2} - \sqrt{5} + \log_e \left(\frac{9+4\sqrt{5}}{1+\sqrt{2}} \right)$

(3) $\sqrt{5} - \sqrt{2} + \log_e \left(\frac{7+4\sqrt{5}}{1+\sqrt{2}} \right)$

(4) $\sqrt{2} - \sqrt{5} + \log_e \left(\frac{7+4\sqrt{5}}{1+\sqrt{2}} \right)$

Ans. (2)

Sol. $I = \int_{-1}^2 1 \cdot \log_e (x + \sqrt{x^2 + 1}) dx$

$$= x \log_e (x + \sqrt{x^2 + 1}) - \int_{-1}^2 \left(\frac{1 + \frac{x}{\sqrt{x^2 + 1}}}{x + \sqrt{x^2 + 1}} \right) dx$$

$$= x \log_e (x + \sqrt{x^2 + 1}) - \int_{-1}^2 \frac{x}{\sqrt{x^2 + 1}} dx$$

$$= x \log_e (x + \sqrt{x^2 + 1}) - \sqrt{x^2 + 1} \Big|_{-1}^2$$

$$= (2 \log_e (2 + \sqrt{5}) - \sqrt{5})$$

$$- (-\log_e (-1 + \sqrt{2}) - \sqrt{2})$$

$$= \log_e (2 + \sqrt{5})^2 - \sqrt{5} + \log_e (\sqrt{2} - 1) + \sqrt{2}$$

$$= \log_e (2 + \sqrt{5})^2 - \sqrt{5} + \log_e (\sqrt{2} - 1) + \sqrt{2}$$

$$= \sqrt{2} - \sqrt{5} + \log_e \left(\frac{(2 + \sqrt{5})^2}{\sqrt{2+1}} \right)$$

$$= \sqrt{2} - \sqrt{5} + \log_e \left(\frac{9 + 4\sqrt{5}}{\sqrt{2+1}} \right)$$

19. Let α, β ; $\alpha > \beta$, be the roots of the equation

$$x^2 - \sqrt{2}x - \sqrt{3} = 0. \text{ Let } P_n = \alpha^n - \beta^n, n \in \mathbb{N}. \text{ Then}$$

$$(11\sqrt{3} - 10\sqrt{2}) P_{10} + (11\sqrt{2} + 10) P_{11} - 11P_{12} \text{ is}$$

equal to :

(1) $10\sqrt{2}P_9$

(2) $10\sqrt{3}P_9$

(3) $11\sqrt{2}P_9$

(4) $11\sqrt{3}P_9$

Ans. (2)

Sol. $x^2 - \sqrt{2}x - \sqrt{3} = 0 \left\langle \begin{matrix} \alpha \\ \beta \end{matrix} \right.$

$$\alpha^{n+2} - \sqrt{2}\alpha^{n+1} - \sqrt{3}\alpha^n = 0$$

$$\text{and } \beta^{n+2} - \sqrt{2}\beta^{n+1} - \sqrt{3}\beta^n = 0$$

Subtracting

$$(\alpha^{n+2} - \beta^{n+2}) - \sqrt{2}(\alpha^{n+1} - \beta^{n+1}) - \sqrt{3}(\alpha^n - \beta^n) = 0$$

$$\Rightarrow P_{n+2} - \sqrt{2}P_{n+1} - \sqrt{3}P_n = 0$$

Put $n = 10$

$$P_{12} - \sqrt{2}P_{11} - \sqrt{3}P_{10} = 0$$

$n = 9$

$$P_{11} - \sqrt{2}P_{10} - \sqrt{3}P_9 = 0$$

$$11(\sqrt{3}P_{10} + \sqrt{2}P_{11} - P_{11}) - 10(\sqrt{2}P_{10} - P_{11})$$

$$= 0 - 10(-\sqrt{3}P_9) = 10\sqrt{3}P_9$$

20. Let $\vec{a} = 2\hat{i} + \alpha\hat{j} + \hat{k}$, $\vec{b} = -\hat{i} + \hat{k}$, $\vec{c} = \beta\hat{j} - \hat{k}$, where α and β are integers and $\alpha\beta = -6$. Let the values of the ordered pair (α, β) for which the area of the parallelogram of diagonals $\vec{a} + \vec{b}$ and $\vec{b} + \vec{c}$ is $\frac{\sqrt{21}}{2}$, be (α_1, β_1) and (α_2, β_2) .

Then $\alpha_1^2 + \beta_1^2 - \alpha_2\beta_2$ is equal to

(1) 17

(2) 24

(3) 21

(4) 19

Ans. (4)

Sol. Area of parallelogram = $\frac{1}{2} |\vec{d}_1 \times \vec{d}_2|$

$$A = \frac{1}{2} |(\vec{a} + \vec{b}) \times (\vec{b} + \vec{c})| = \frac{\sqrt{21}}{2}$$

$$\text{so, } \vec{a} + \vec{b} = \hat{i} + \alpha\hat{j} + 2\hat{k}$$

$$\vec{b} + \vec{c} = -\hat{i} + \beta\hat{j}$$

$$(\vec{a} + \vec{b}) \times (\vec{b} + \vec{c}) = \begin{vmatrix} \hat{i} & \hat{j} & \hat{k} \\ 1 & \alpha & 2 \\ -1 & \beta & 0 \end{vmatrix}$$

$$= \hat{i}(-2\beta) - \hat{j}(2) + \hat{k}(\beta + \alpha)$$

$$|(\vec{a} + \vec{b}) \times (\vec{b} + \vec{c})| = \sqrt{4\beta^2 + 4 + (\alpha + \beta)^2} = \sqrt{21}$$

$$4\beta^2 + 4 + \alpha^2 + \beta^2 + 2\alpha\beta = 21$$

$$\alpha^2 + 5\beta^2 - 12 = 17$$

$$\alpha^2 + 5\beta^2 = 29$$

$$\text{and } \alpha\beta = -6$$

and given α, β are integers

so,

$$\alpha = -3, \beta = 2$$

or

$$\alpha = 3, \beta = -2$$

$$(\alpha_1, \beta_1) = (-3, 2)$$

$$(\alpha_2, \beta_2) = (3, -2)$$

$$\alpha_1^2 + \beta_1^2 - \alpha_2\beta_2 = 9 + 4 + 6 = 19$$

SECTION-B

21. Consider the circle $C : x^2 + y^2 = 4$ and the parabola $P : y^2 = 8x$. If the set of all values of α , for which three chords of the circle C on three distinct lines passing through the point $(\alpha, 0)$ are bisected by the parabola P is the interval (p, q) , then $(2q - p)^2$ is equal to _____.

Ans. (80)

Sol.

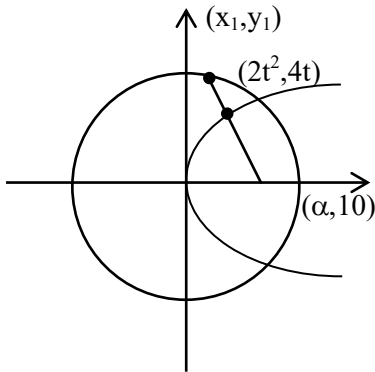

$$T = S_1$$

$$xx_1 + yy_1 = x_1^2 + y_1^2$$

$$\alpha x_1 = x_1^2 + y_1^2$$

$$\alpha(2t^2) = 4t^4 + 16t^2$$

$$\alpha = 2t^2 + 8$$

$$\frac{\alpha - 8}{2} = t^2$$

$$\text{Also, } 4t^4 + 16t^2 - 4 < 0$$

$$t^2 = -2 + \sqrt{5}$$

$$\alpha = 4 + 2\sqrt{5}$$

$$\therefore \alpha \in (8, 4 + 2\sqrt{5})$$

$$\therefore (2q - p)^2 = 80$$

22. Let the set of all values of p , for which $f(x) = (p^2 - 6p + 8)(\sin^2 2x - \cos^2 2x) + 2(2 - p)x + 7$ does not have any critical point, be the interval (a, b) . Then $16ab$ is equal to _____.

Ans. (252)

Sol. $f(x) = -(p^2 - 6p + 8) \cos 4x + 2(2 - p)x + 7$

$$f'(x) = +4(p^2 - 6p + 8) \sin 4x + (4 - 2p) \neq 0$$

$$\sin 4x \neq \frac{2p - 4}{4(p - 4)(p - 2)}$$

$$\sin 4x \neq \frac{2(p - 2)}{4(p - 4)(p - 2)}$$

$$p \neq 2$$

$$\sin 4x \neq \frac{1}{2(p - 4)}$$

$$\Rightarrow \left| \frac{1}{2(p - 4)} \right| > 1$$

on solving we get

$$\therefore p \in \left(\frac{7}{2}, \frac{9}{2} \right)$$

$$\text{Hence } a = \frac{7}{2}, b = \frac{9}{2}$$

$$\therefore 16ab = 252$$

23. For a differentiable function $f : \mathbb{R} \rightarrow \mathbb{R}$, suppose $f'(x) = 3f(x) + \alpha$, where $\alpha \in \mathbb{R}$, $f(0) = 1$ and $\lim_{x \rightarrow -\infty} f(x) = 7$. Then $9f(-\log_e 3)$ is equal to _____.

Ans. (61)

Sol. $\frac{dy}{dx} - 3y = \alpha$

$$\text{If } y = e^{\int -3dx} = e^{-3x}$$

$$\therefore y - e^{-3x} = \int e^{-3x} \cdot \alpha dx$$

$$y e^{-3x} = \frac{\alpha e^{-3x}}{-3} + c$$

$$(* e^{3x})$$

$$y = \frac{\alpha}{-3} + C \cdot e^{3x}$$

on substituting $x = 0, y = 1$

$$x \rightarrow -\infty, y = 7$$

$$\text{we get } y = 7 - 6e^{3x}$$

$$9f(-\log_e 3) = 61$$

24. The number of integers, between 100 and 1000 having the sum of their digits equals to 14, is _____.

Ans. (70)

Sol. $N = a b c$

(i) All distinct digits

$$a + b + c = 14$$

$$a \geq 1$$

$$b, c \in \{0 \text{ to } 9\}$$

by hit & trial : 8 cases

$$(6, 5, 3) \quad (8, 6, 0) \quad (9, 4, 1)$$

$$(7, 6, 1) \quad (8, 5, 1) \quad (9, 3, 2)$$

$$(7, 5, 2) \quad (8, 4, 2)$$

$$(7, 4, 3) \quad (9, 5, 0)$$

(ii) 2 same, 1 diff $a = b ; c$

$$2a + c = 14$$

by values :

$$\left. \begin{array}{l} (3, 8) \\ (4, 6) \\ (5, 4) \\ (6, 2) \\ (7, 0) \end{array} \right\} \begin{array}{l} \text{Total} \\ 3! \\ 2! \times 5 - 1 \end{array}$$

$$= 14 \text{ cases}$$

(iii) all same :

$$3a = 14$$

$$a = \frac{14}{3} \times \text{rejected}$$

0 cases

Hence, Total cases :

$$8 \times 3! + 2 \times (4) + 14$$

$$= 48 + 22$$

$$= 70$$

25. Let $A = \{(x, y) : 2x + 3y = 23, x, y \in \mathbb{N}\}$ and $B = \{x : (x, y) \in A\}$. Then the number of one-one functions from A to B is equal to _____.

Ans. (24)

Sol. $2x + 3y = 23$

$$x = 1 \quad y = 7$$

$$x = 4 \quad y = 5$$

$$x = 7 \quad y = 3$$

$$x = 10 \quad y = 1$$

A B

$$(1, 7) \quad 1$$

$$(4, 5) \quad 4$$

$$(7, 3) \quad 7$$

$$(10, 1) \quad 10$$

The number of one-one functions from A to B is equal to 4!

26. Let A, B and C be three points on the parabola $y^2 = 6x$ and let the line segment AB meet the line L through C parallel to the x-axis at the point D. Let M and N respectively be the feet of the perpendiculars from A and B on L.

Then $\left(\frac{AM \cdot BN}{CD}\right)^2$ is equal to _____.

Ans. (36)

Sol.

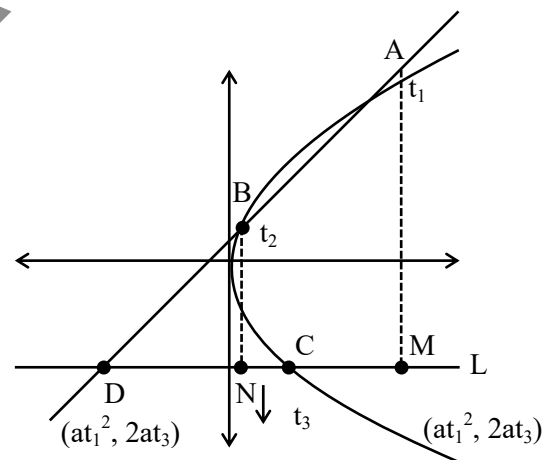

Sol.

$$m_{AB} = m_{AD}$$

$$\Rightarrow \frac{2}{t_1 + t_2} = \frac{2a(t_1 - t_3)}{at_1^2 - \alpha}$$

$$\Rightarrow at_1^2 - \alpha = a\{t_1^2 - t_1t_3 + t_1t_2 - t_2t_3\}$$

$$\Rightarrow \alpha = a(t_1t_3 + t_2t_3 - t_1t_2)$$

$$AM = |2a(t_1 - t_3)|, \quad BN = |2a(t_2 - t_3)|,$$

$$CD = |at_3^2 - \alpha|$$

$$\begin{aligned}
 CD &= |at_3^2 - a(t_1t_3 + t_2t_3 - t_1t_2)| \\
 &= a|t_3^2 - t_1t_3 - t_2t_3 + t_1t_2| \\
 &= a|t_3(t_3 - t_1) - t_2(t_3 - t_1)| \\
 CD &= a|(t_3 - t_2)(t_3 - t_1)| \\
 \left(\frac{AM \cdot BN}{CD}\right)^2 &= \left\{ \frac{2a(t_1 - t_3) \cdot 2a(t_2 - t_3)}{a(t_3 - t_2)(t_3 - t_1)} \right\}^2 \\
 16a^2 &= 16 \times \frac{9}{4} = 36
 \end{aligned}$$

27. The square of the distance of the image of the point (6, 1, 5) in the line $\frac{x-1}{3} = \frac{y}{2} = \frac{z-2}{4}$, from the origin is _____.

Ans. (62)

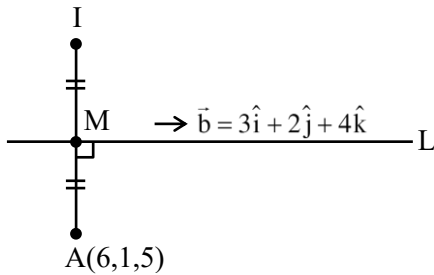

Sol.

$$\begin{aligned}
 \text{Let } M(3\lambda + 1, 2\lambda, 4\lambda + 2) \\
 \vec{AM} \cdot \vec{b} &= 0 \\
 \Rightarrow 9\lambda - 15 + 4\lambda - 2 + 16\lambda - 12 &= 0 \\
 \Rightarrow 29\lambda &= 29 \\
 \Rightarrow \lambda &= 1 \\
 M(4, 2, 6), I &= (2, 3, 7) \\
 \text{Required Distance} &= \sqrt{4 + 9 + 49} = \sqrt{62} \\
 \text{Ans. } &62
 \end{aligned}$$

28. If $\left(\frac{1}{\alpha+1} + \frac{1}{\alpha+2} + \dots + \frac{1}{\alpha+1012}\right) - \left(\frac{1}{2 \cdot 1} + \frac{1}{4 \cdot 3} + \frac{1}{6 \cdot 5} + \dots + \frac{1}{2024 \cdot 2023}\right) = \frac{1}{2024}$, then α is equal to-
Ans. (1011)

$$\begin{aligned}
 \text{Sol. } &\left(\frac{1}{\alpha+1} + \frac{1}{\alpha+2} + \dots + \frac{1}{\alpha+2012}\right) \\
 &- \left\{ \left(\frac{1}{1} - \frac{1}{2}\right) + \left(\frac{1}{3} - \frac{1}{4}\right) + \dots + \left(\frac{1}{2023} - \frac{1}{2024}\right) \right\} = \frac{1}{2024} \\
 \Rightarrow &\left(\frac{1}{\alpha+1} + \frac{1}{\alpha+2} + \dots + \frac{1}{\alpha+2012}\right) \\
 &- \left\{ \left(\frac{1}{1} + \frac{1}{2} + \frac{1}{3} + \frac{1}{4}\right) + \dots + \frac{1}{2023} \right. \\
 &\left. - \frac{1}{2024} - 2\left(\frac{1}{2} + \frac{1}{4} + \dots + \frac{1}{2022}\right) \right\} = \frac{1}{2024} \\
 \Rightarrow &\left(\frac{1}{\alpha+1} + \frac{1}{\alpha+2} + \dots + \frac{1}{\alpha+2012}\right) \\
 &- \left(\frac{1}{1} + \frac{1}{2} + \dots + \frac{1}{2023}\right) \\
 &+ \frac{1}{2024} + \left(\frac{1}{1} + \frac{1}{2} + \dots + \frac{1}{1011}\right) = \frac{1}{2024} \\
 \Rightarrow &\frac{1}{\alpha+1} + \frac{1}{\alpha+2} + \dots + \frac{1}{\alpha+2012} \\
 &= \frac{1}{1012} + \frac{1}{1013} + \dots + \frac{1}{2023} \\
 \Rightarrow &\alpha = 1011
 \end{aligned}$$

29. Let the inverse trigonometric functions take principal values. The number of real solutions of the equation $2 \sin^{-1} x + 3 \cos^{-1} x = \frac{2\pi}{5}$, is _____.

Ans. (0)

$$\begin{aligned}
 \text{Sol. } 2 \sin^{-1} x + 3 \cos^{-1} x &= \frac{2\pi}{5} \\
 \Rightarrow \pi + \cos^{-1} x &= \frac{2\pi}{5} \\
 \Rightarrow \cos^{-1} x &= \frac{-3\pi}{5}
 \end{aligned}$$

Not possible

Ans. 0

30. Consider the matrices : $A = \begin{bmatrix} 2 & -5 \\ 3 & m \end{bmatrix}$, $B = \begin{bmatrix} 20 \\ m \end{bmatrix}$

and $X = \begin{bmatrix} x \\ y \end{bmatrix}$. Let the set of all m , for which the system of equations $AX = B$ has a negative solution (i.e., $x < 0$ and $y < 0$), be the interval (a, b) .

Then $8 \int_a^b |A| dm$ is equal to _____.

Ans. (450)

Sol. $A = \begin{pmatrix} 2 & -5 \\ 3 & m \end{pmatrix}$, $B = \begin{pmatrix} 20 \\ m \end{pmatrix}$

$$X = \begin{pmatrix} x \\ y \end{pmatrix}$$

$$2x - 5y = 20 \quad \dots(1)$$

$$3x + my = m \quad \dots(2)$$

$$\Rightarrow y = \frac{2m - 60}{2m + 15}$$

$$y < 0 \Rightarrow m \in \left(\frac{-15}{2}, 30 \right)$$

$$x = \frac{25m}{2m + 15}$$

$$x < 0 \Rightarrow m \in \left(\frac{-15}{2}, 0 \right)$$

$$\Rightarrow m \in \left(\frac{-15}{2}, 0 \right)$$

$$|A| = 2m + 15$$

Now,

$$8 \int_{\frac{-15}{2}}^0 (2m + 15) dm = 8 \left\{ m^2 + 15m \right\}_{\frac{-15}{2}}^0$$

$$\Rightarrow 8 \left\{ - \left(\frac{225}{4} - \frac{225}{2} \right) \right\}$$

$$= 8 \times \frac{225}{4} = 450$$

PHYSICS

TEST PAPER WITH SOLUTION

SECTION-A

- 31.** A nucleus at rest disintegrates into two smaller nuclei with their masses in the ratio of 2:1. After disintegration they will move :-
- (1) In opposite directions with speed in the ratio of 1:2 respectively
 - (2) In opposite directions with speed in the ratio of 2:1 respectively
 - (3) In the same direction with same speed.
 - (4) In opposite directions with the same speed.

Ans. (1)

Sol. By conservation of momentum

$$p_i = p_f$$

$$0 = m_1 u_1 + m_2 u_2$$

$$\frac{u_1}{u_2} = -\left[\frac{1}{2}\right] \text{ as } \frac{m_1}{m_2} = \frac{2}{1}$$

move in opposite direction with speed ratio 1 : 2

- 32.** The following figure represents two biconvex lenses L_1 and L_2 having focal length 10 cm and 15 cm respectively. The distance between L_1 & L_2 is :

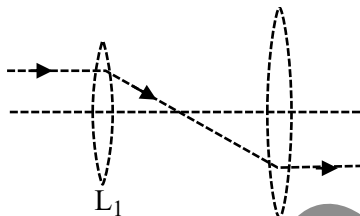

- (1) 10 cm
- (2) 15 cm
- (3) 25 cm
- (4) 35 cm

Ans. (3)

Sol.

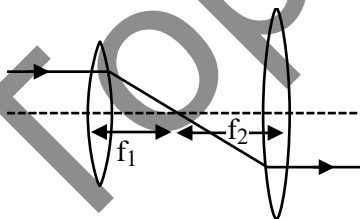

$$D = f_1 + f_2 = 25 \text{ cm}$$

Paraxial parallel rays pass through focus and ray from focus of convex lens will become parallel

- 33.** The temperature of a gas is -78°C and the average translational kinetic energy of its molecules is K . The temperature at which the average translational kinetic energy of the molecules of the same gas becomes $2K$ is :

- (1) -39°C
- (2) 117°C
- (3) 127°C
- (4) -78°C

Ans. (2)

Sol. $K.E = \frac{nf_1RT}{2}$

$$T_i = -78^\circ \text{C} \rightarrow 273 + [-78^\circ \text{C}] = 195 \text{K}$$

$$K.E \propto T$$

To double the K.E energy temp also become double

$$T_f = 390 \text{ K}$$

$$T_f = 117^\circ \text{C}$$

- 34.** A hydrogen atom in ground state is given an energy of 10.2 eV. How many spectral lines will be emitted due to transition of electrons ?

- (1) 6
- (2) 3
- (3) 10
- (4) 1

Ans. (4)

Sol. Hydrogen will be in first excited state therefore it will emit one spectral line corresponding to transition b/w energy level 2 to 1

- 35.** The magnetic field in a plane electromagnetic wave is $B_y = (3.5 \times 10^{-7}) \sin (1.5 \times 10^3 x + 0.5 \times 10^{11} t)$ T. The corresponding electric field will be

- (1) $E_y = 1.17 \sin (1.5 \times 10^3 x + 0.5 \times 10^{11} t) \text{Vm}^{-1}$
- (2) $E_z = 105 \sin (1.5 \times 10^3 x + 0.5 \times 10^{11} t) \text{Vm}^{-1}$
- (3) $E_z = 1.17 \sin (1.5 \times 10^3 x + 0.5 \times 10^{11} t) \text{Vm}^{-1}$
- (4) $E_y = 10.5 \sin (1.5 \times 10^3 x + 0.5 \times 10^{11} t) \text{Vm}^{-1}$

Ans. (2)

Sol. $E_0 = B_0 c$

$$E_0 = 3 \times 10^8 \times (3.5 \times 10^{-7}) \sin (1.5 \times 10^3 x + 0.5 \times 10^{11} t)$$

$$E_0 = 105 \sin (1.5 \times 10^3 x + 0.5 \times 10^{11} t) \text{Vm}^{-1}$$

Data inconsistent while calculating speed of wave. You can challenge for data.

36. A square loop of side 15 cm being moved towards right at a constant speed of 2 cm/s as shown in figure. The front edge enters the 50 cm wide magnetic field at $t = 0$. The value of induced emf in the loop at $t = 10$ s will be :

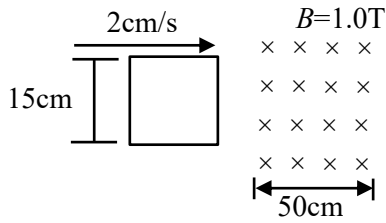

- (1) 0.3 mV (2) 4.5 mV
 (3) zero (4) 3 mV

Ans. (3)

Sol. At $t = 10$ sec complete loop is in magnetic field therefore no change in flux

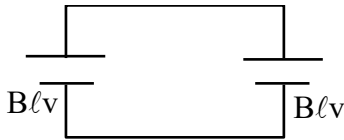

$$e = \frac{d\phi}{dt} = 0$$

$e = 0$ for complete loop

37. Two cars are travelling towards each other at speed of 20 m s^{-1} each. When the cars are 300 m apart, both the drivers apply brakes and the cars retard at the rate of 2 m s^{-2} . The distance between them when they come to rest is :

- (1) 200 m (2) 50 m
 (3) 100 m (4) 25 m

Ans. (3)

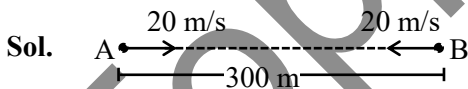

$$|\vec{u}_{BA}| = 40 \text{ m/s}$$

$$|\vec{a}_{BA}| = 4 \text{ m/s}^2$$

Apply $(v^2 = u^2 + 2as)_{\text{relative}}$

$$0 = (40)^2 + 2(-4)(S)$$

$$S = 200 \text{ m}$$

$$\text{Remaining distance} = 300 - 200 = 100 \text{ m}$$

38. The I - V characteristics of an electronic device shown in the figure. The device is :

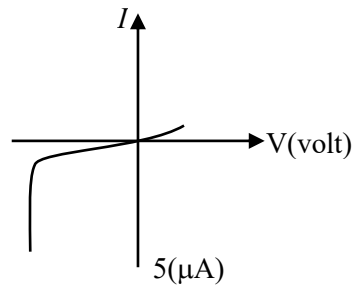

- (1) a solar cell
 (2) a transistor which can be used as an amplifier
 (3) a zener diode which can be used as voltage regulator
 (4) a diode which can be used as a rectifier

Ans. (3)

Sol. Theory

Zener diode used as voltage regulator

39. The excess pressure inside a soap bubble is thrice the excess pressure inside a second soap bubble. The ratio between the volume of the first and the second bubble is :

- (1) 1 : 9 (2) 1 : 3
 (3) 1 : 81 (4) 1 : 27

Ans. (4)

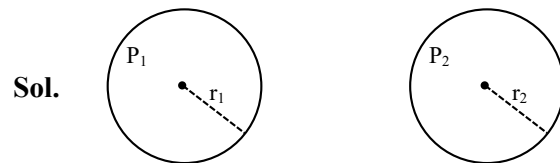

Sol.

$$P_1 - P_0 = \frac{4T}{r_1}$$

$$P_2 - P_0 = \frac{4T}{r_2}$$

$$P_1 - P_0 = 3(P_2 - P_0)$$

$$\frac{4T}{r_1} = 3 \frac{4T}{r_2}$$

$$r_2 = 3r_1$$

$$\frac{V_1}{V_2} = \frac{\frac{4}{3}\pi r_1^3}{\frac{4}{3}\pi r_2^3} = \frac{1}{27}$$

40. The de-Broglie wavelength associated with a particle of mass m and energy E is $h/\sqrt{2mE}$. The dimensional formula for Planck's constant is :
- (1) $[ML^{-1}T^{-2}]$ (2) $[ML^2T^{-1}]$
 (3) $[MLT^{-2}]$ (4) $[M^2L^2T^{-2}]$

Ans. (2)

Sol. $\lambda = \frac{h}{\sqrt{2mE}}$ or $E = h\nu$

$[ML^2T^{-2}] = h[T^{-1}]$

$h = [ML^2T^{-1}]$

41. A satellite of 10^3 kg mass is revolving in circular orbit of radius $2R$. If $\frac{10^4 R}{6}$ J energy is supplied to

the satellite, it would revolve in a new circular orbit of radius :

(use $g = 10m/s^2$, $R =$ radius of earth)

- (1) $2.5 R$ (2) $3 R$
 (3) $4 R$ (4) $6 R$

Ans. (4)

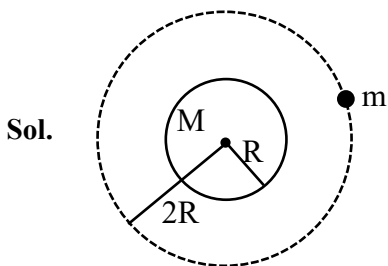

Sol.

Total energy = $\frac{-GMm}{2(2R)}$

if energy = $\frac{10^4 R}{6}$ is added then

$\frac{-GMm}{4R} + \frac{10^4 R}{6} = \frac{-GMm}{2r}$

where r is new radius of revolving and $g = \frac{GM}{R^2}$

$\frac{mgR}{4} + \frac{10^4 R}{6} = -\frac{mgR^2}{2r}$ ($m = 10^3$ kg)

$-\frac{10^3 \times 10 \times R}{4} + \frac{10^4 R}{6} = -\frac{10^3 \times 10 \times R^2}{2r}$

$-\frac{1}{4} + \frac{1}{6} = -\frac{R}{2r}$

$r = 6R$

42. The effective resistance between A and B , if resistance of each resistor is R , will be

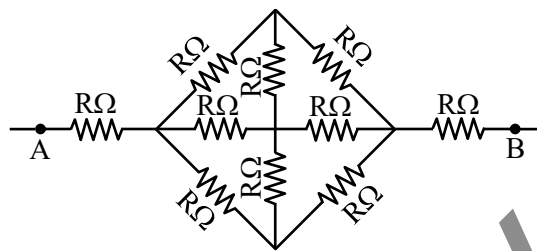

- (1) $\frac{2}{3} R$ (2) $\frac{8R}{3}$
 (3) $\frac{5R}{3}$ (4) $\frac{4R}{3}$

Ans. (2)

Sol. From symmetry we can remove two middle resistance.

New circuit is

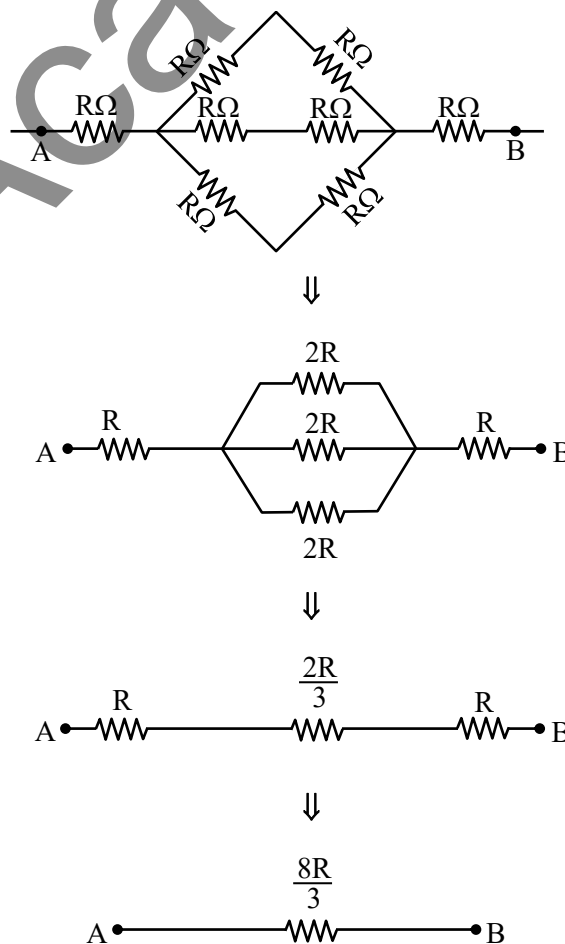

43. Five charges $+q$, $+5q$, $-2q$, $+3q$ and $-4q$ are situated as shown in the figure. The electric flux due to this configuration through the surface S is :

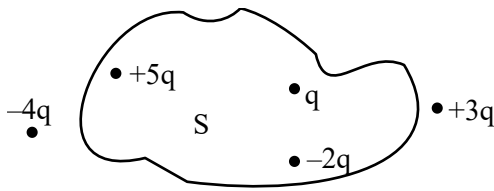

- (1) $\frac{5q}{\epsilon_0}$ (2) $\frac{4q}{\epsilon_0}$
 (3) $\frac{3q}{\epsilon_0}$ (4) $\frac{q}{\epsilon_0}$

Ans. (2)

Sol. As per Gauss theorem,

$$\phi = \frac{q_{in}}{\epsilon_0} = \frac{q + (-2q) + 5q}{\epsilon_0}$$

$$\frac{4q}{\epsilon_0}$$

44. A proton and a deuteron ($q = +e$, $m = 2.0u$) having same kinetic energies enter a region of uniform magnetic field \vec{B} , moving perpendicular to \vec{B} . The ratio of the radius r_d of deuteron path to the radius r_p of the proton path is :

- (1) 1 : 1 (2) 1 : $\sqrt{2}$
 (3) $\sqrt{2}$: 1 (4) 1 : 2

Ans. (3)

Sol. In uniform magnetic field,

$$R = \frac{mv}{qB} = \frac{\sqrt{2m(K.E)}}{qB}$$

Since same K.E

$$R \propto \frac{\sqrt{m}}{q}$$

$$\therefore \frac{R_{deuteron}}{R_{proton}} = \sqrt{\frac{m_d}{m_p}} \times \frac{q_p}{q_d}$$

$$= \sqrt{2} \times 1$$

$$\therefore \gamma_d : \gamma_p = \sqrt{2} : 1$$

45. UV light of 4.13 eV is incident on a photosensitive metal surface having work function 3.13 eV. The maximum kinetic energy of ejected photoelectrons will be :

- (1) 4.13 eV (2) 1 eV
 (3) 3.13 eV (4) 7.26 eV

Ans. (2)

Sol. $E_{\text{photon}} = (\text{work function}) + K.E_{\text{max}}$

$$\therefore 4.13 = 3.13 + K.E_{\text{max}}$$

$$\therefore K.E_{\text{max}} = 1 \text{ eV}$$

46. The energy released in the fusion of 2 kg of hydrogen deep in the sun is E_H and the energy released in the fission of 2 kg of ^{235}U is E_U . The ratio $\frac{E_H}{E_U}$ is approximately :

(Consider the fusion reaction as $4^1_1\text{H} + 2e^- \rightarrow ^4_2\text{He} + 2\nu + 6\gamma + 26.7 \text{ MeV}$, energy released in the fission reaction of ^{235}U is 200 MeV per fission nucleus and $N_A = 6.023 \times 10^{23}$)

- (1) 9.13 (2) 15.04
 (3) 7.62 (4) 25.6

Ans. (3)

Sol. In each fusion reaction, 4 ^1_1H nuclei are used.

$$\text{Energy released per Nuclei of } ^1_1\text{H} = \frac{26.7}{4} \text{ MeV}$$

\therefore Energy released by 2 kg hydrogen (E_H)

$$= \frac{2000}{1} \times N_A \times \frac{26.7}{4} \text{ MeV}$$

&

\therefore Energy released by 2 kg Uranium (E_U)

$$= \frac{2000}{235} \times N_A \times 200 \text{ MeV}$$

So,

$$\frac{E_H}{E_U} = 235 \times \frac{26.7}{4 \times 200} = 7.84$$

\therefore Approximately close to 7.62

47. A real gas within a closed chamber at 27°C undergoes the cyclic process as shown in figure. The gas obeys $PV^3 = RT$ equation for the path A to B . The net work done in the complete cycle is (assuming $R = 8\text{J/molK}$):

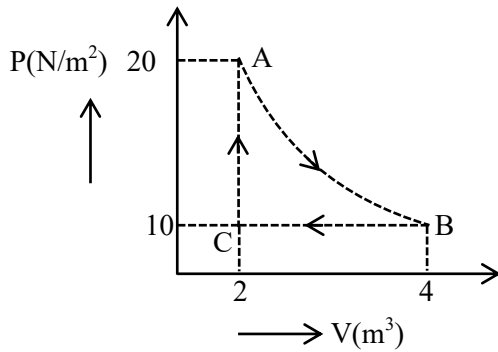

- (1) 225 J (2) 205 J
 (3) 20 J (4) -20 J

Ans. (2)

Sol. $W_{AB} = \int PdV$ (Assuming T to be constant)

$$= \int \frac{RTdV}{V^3}$$

$$= RT \int_2^4 V^{-3} dV$$

$$= 8 \times 300 \times \left(-\frac{1}{2} \left[\frac{1}{4^2} - \frac{1}{2^2} \right] \right)$$

$$= 225\text{ J}$$

$$W_{BC} = P \int_4^2 dV = 10(2 - 4) = -20\text{ J}$$

$$W_{CA} = 0$$

$$\therefore W_{\text{cycle}} = 205\text{ J}$$

Note : Data is inconsistent in process AB.

So needs to be challenged.

48. A 1 kg mass is suspended from the ceiling by a rope of length 4 m . A horizontal force ' F ' is applied at the mid point of the rope so that the rope makes an angle of 45° with respect to the vertical axis as shown in figure. The magnitude of F is :

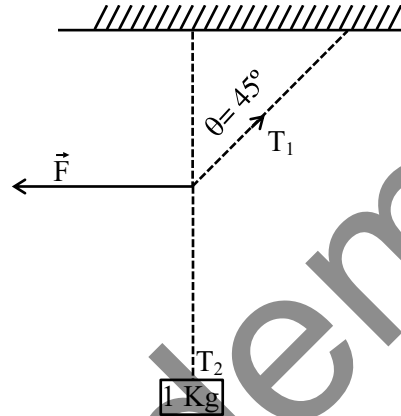

- (1) $\frac{10}{\sqrt{2}}\text{ N}$ (2) 1 N
 (3) $\frac{1}{10 \times \sqrt{2}}\text{ N}$ (4) 10 N

Ans. (4)

Sol. $T_1 \sin 45^\circ = F$

$$T_1 \cos 45^\circ = T_2 = 1 \times g$$

$$\therefore \tan 45^\circ = \frac{F}{g}$$

$$\therefore F = 10\text{ N}$$

49. A spherical ball of radius $1 \times 10^{-4}\text{ m}$ and density 10^5 kg/m^3 falls freely under gravity through a distance h before entering a tank of water, If after entering in water the velocity of the ball does not change, then the value of h is approximately :

(The coefficient of viscosity of water is $9.8 \times 10^{-6}\text{ N s/m}^2$)

- (1) 2296 m (2) 2249 m
 (3) 2518 m (4) 2396 m

Ans. (3)

Sol. $V_T = \frac{2g R^2 [\rho_B - \rho_L]}{9 \eta}$

$\Rightarrow V_T = \frac{2}{9} \times \frac{10 \times (10^{-4})^2}{9.8 \times 10^{-6}} [10^5 - 10^3]$

$\Rightarrow V_T = 224.5$

when ball fall from height (h)

$V = \sqrt{2gh}$

$h = \left(\frac{V^2}{2g}\right) = 2518m$

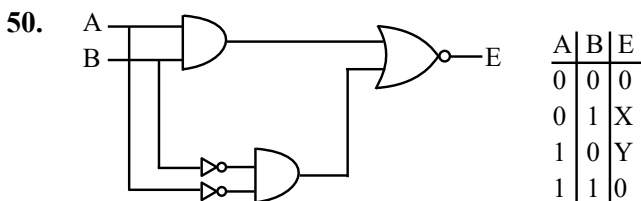

In the truth table of the above circuit the value of X and Y are :

- (1) 1, 1 (2) 1, 0
 (3) 0, 1 (4) 0, 0

Ans. (1)

Sol. For x

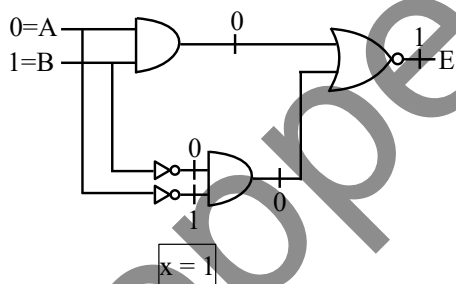

For y

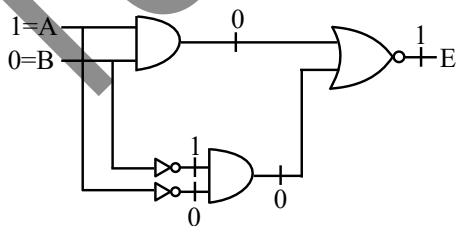

SECTION-B

- 51.** A straight magnetic strip has a magnetic moment of 44 Am^2 . If the strip is bent in a semicircular shape, its magnetic moment will be Am^2
 (Given $\pi = \frac{22}{7}$)

Ans. (28)

Sol. Magnetic moment of straight wire = $m \times \ell = 44$

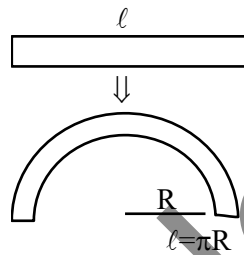

Magnetic moment of arc
 $= m \times 2r$
 $= m \times \frac{2\ell}{\pi}$
 $= \frac{44 \times 2}{\pi} = \frac{88}{\pi} = 28$

- 52.** A particle of mass 0.50 kg executes simple harmonic motion under force $F = -50(\text{Nm}^{-1})x$. The time period of oscillation is $\frac{x}{35}$ s. The value of x is

.....
 (Given $\pi = \frac{22}{7}$)

Ans. (22)

Sol. $m = 0.5 \text{ kg}$
 $F = -50(x)$
 $ma = (-50x)$
 $0.5 a = -50x$
 $a = (-100x)$
 $\omega^2 = 100 \Rightarrow (\omega = 10)$
 $T = \frac{2\pi}{10} = \left(\frac{\pi}{5}\right) = \frac{22}{7 \times 15} = \left(\frac{22}{35}\right)$
 $\frac{\pi}{35} = \frac{22}{35} \Rightarrow \boxed{x = 22}$

53. A capacitor of reactance $4\sqrt{3}\Omega$ and a resistor of resistance 4Ω are connected in series with an ac source of peak value $8\sqrt{2}V$. The power dissipation in the circuit isW.

Ans. (4)

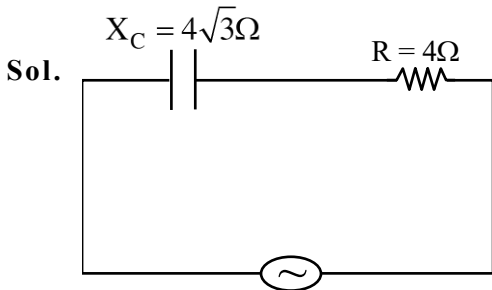

$$Z = \sqrt{R^2 + X^2L}$$

$$Z = \sqrt{4^2 + (4\sqrt{3})^2} = 8\Omega$$

$$V_{\text{rms}} = \frac{V}{\sqrt{2}} = \frac{8\sqrt{2}}{\sqrt{2}} = (8V)$$

$$I_{\text{rms}} = \frac{V_{\text{rms}}}{Z} = \frac{8}{8} = 1A$$

$$\text{Power dissipated} = I_{\text{rms}}^2 \times R = 1 \times 4 = (4W)$$

54. An electric field $\vec{E} = (2x\hat{i})NC^{-1}$ exists in space. A cube of side 2m is placed in the space as per figure given below. The electric flux through the cube is Nm^2/C .

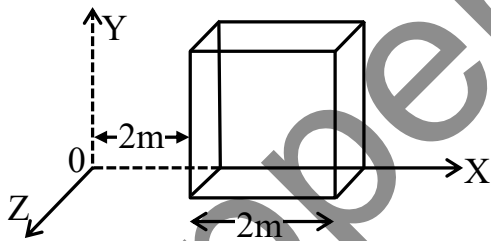

Ans. (16)

Sol.

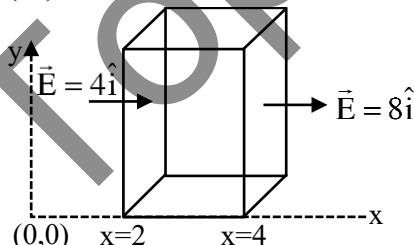

$$\vec{E} = 2x\hat{i}$$

$$\phi = \vec{E} \cdot \vec{A}$$

$$\phi_{\text{in}} = -4 \times 4 = -16 Nm^2 / c$$

$$\phi_{\text{out}} = 8 \times 4 = 32 Nm^2 / c$$

$$d_{\text{net}} = \phi_{\text{in}} + \phi_{\text{out}} = -16 + 32 = 16 Nm^2 / c$$

55. A circular disc reaches from top to bottom of an inclined plane of length l . When it slips down the plane, it takes t s. When it rolls down the plane

then it takes $\left(\frac{\alpha}{2}\right)^{1/2} t$ s, where α is

Ans. (3)

Sol. For slipping

$$a = g \sin \theta$$

$$l = \frac{1}{2} at^2 \Rightarrow t = \sqrt{\frac{2l}{g \sin \theta}}$$

For rolling

$$a' = \frac{g \sin \theta}{1 + \frac{k^2}{R^2}} \left[k = \frac{R}{\sqrt{2}} \right]$$

$$\Rightarrow a' = \frac{2g \sin \theta}{3}$$

$$l = \frac{1}{2} a' (t')^2$$

$$\Rightarrow t' = \sqrt{\frac{6l}{2g \sin \theta}} = \sqrt{\frac{\alpha}{2}} \sqrt{\frac{2l}{g \sin \theta}}$$

$$\Rightarrow \boxed{\alpha = 3}$$

56. To determine the resistance (R) of a wire, a circuit is designed below, The V-I characteristic curve for this circuit is plotted for the voltmeter and the ammeter readings as shown in figure. The value of R is Ω .

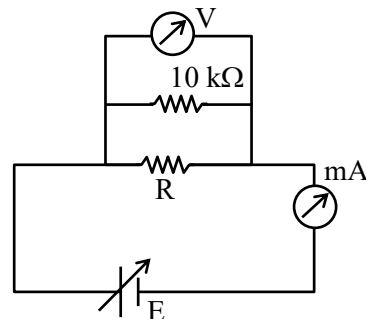

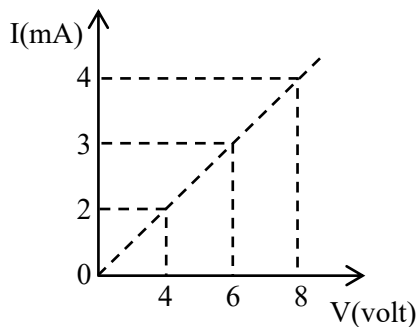

Ans. (2500)

Sol. $R_{eq} = \frac{10^4 R}{10^4 + R}$

$E = 4V, I = 2mA$

$I = \frac{E}{R_{eq}} \Rightarrow 2 \times 10^{-3} = \frac{4(10^4 + R)}{10^4 R}$

$\Rightarrow 20R = 40000 + 4R$

$16R = 40000$

$R = 2500\Omega$

57. The resultant of two vectors \vec{A} and \vec{B} is perpendicular to \vec{A} and its magnitude is half that of \vec{B} . The angle between vectors \vec{A} and \vec{B} is

Ans. (150)

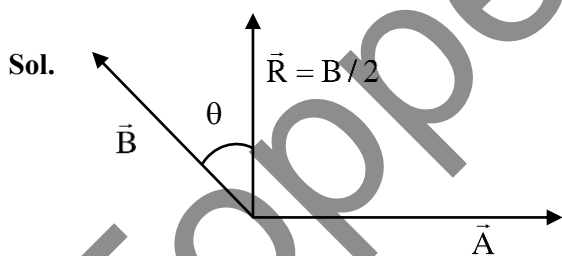

$B \cos \theta = \frac{B}{2}$

$\Rightarrow \theta = 60^\circ$

So, angle between \vec{A} & \vec{B} is $90^\circ + 60^\circ = 150^\circ$

58. Monochromatic light of wavelength 500 nm is used in Young's double slit experiment. An interference pattern is obtained on a screen. When one of the slits is covered with a very thin glass plate (refractive index = 1.5), the central maximum is shifted to a position previously occupied by the 4th bright fringe. The thickness of the glass-plate is μm .

Ans. (4)

Sol. $(\mu - 1)t = n\lambda$

$(1.5 - 1)t = 4 \times 500 \times 10^{-9} \text{ m}$

$t = 4000 \times 10^{-9} \text{ m}$

$t = 4\mu\text{m}$

59. A force $(3x^2 + 2x - 5) \text{ N}$ displaces a body from $x = 2 \text{ m}$ to $x = 4 \text{ m}$. Work done by this force isJ.

Ans. (58)

Sol. $W = \int_{x_1}^{x_2} F dx$

$W = \int_2^4 (3x^2 + 2x - 5) dx$

$W = [x^3 + x^2 - 5x]_2^4$

$W = [60 - 2]J = 58J$

60. At room temperature (27°C), the resistance of a heating element is 50Ω . The temperature coefficient of the material is $2.4 \times 10^{-4} \text{ }^\circ\text{C}^{-1}$. The temperature of the element, when its resistance is 62Ω , is $^\circ\text{C}$.

Ans. (1027)

Sol. $R = R_0(1 + \alpha\Delta T)$

$62 = 50 [1 + 2.4 \times 10^{-4} \Delta T]$

$\Delta T = 1000^\circ\text{C}$

$\Rightarrow T - 27^\circ = 1000^\circ\text{C}$

$T = 1027^\circ\text{C}$

CHEMISTRY

TEST PAPER WITH SOLUTION

SECTION-A

61. The candela is the luminous intensity, in a given direction, of a source that emits monochromatic radiation of frequency 'A' $\times 10^{12}$ hertz and that has a radiant intensity in that direction of $\frac{1}{B}$ watt per steradian. 'A' and 'B' are respectively

- (1) 540 and $\frac{1}{683}$
- (2) 540 and 683
- (3) 450 and $\frac{1}{683}$
- (4) 450 and 683

Ans. (2)

Sol. The candela is the luminous intensity of a source that emits monochromatic radiation of frequency radiation of frequency 540×10^{12} Hz and has a radiant intensity in that direction of $\frac{1}{683}$ w/sr. It is unit of Candela.

62. The correct stability order of the following resonance structures of $\text{CH}_3-\text{CH}=\text{CH}-\text{CHO}$ is

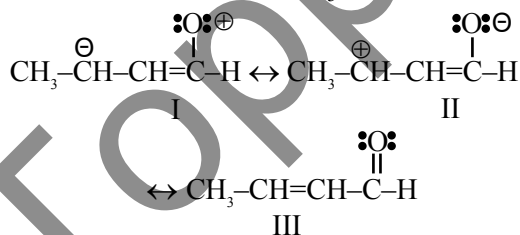

- (1) II > III > I
- (2) III > II > I
- (3) I > II > III
- (4) II > I > III

Ans. (2)

Sol. $\text{CH}_3-\text{CH}=\text{CH}-\overset{\text{O}}{\parallel}{\text{C}}\text{H}$ (III)
 \downarrow
 Non Polar R.S.
 More No of covalent bond

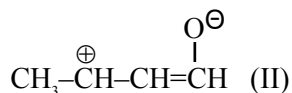

\downarrow
 Having -ve charge on more electronegative atom

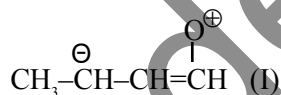

\downarrow
 Having -ve charge on less electronegative atom
 Stability order III > II > I

63. Total number of stereo isomers possible for the given structure:

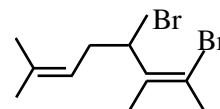

- (1) 8
- (2) 2
- (3) 4
- (4) 3

Ans. (1)

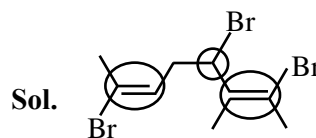

There are three stereo center
 So No of stereoisomer = $2^3 = 8$

64. The correct increasing order for bond angles among BF_3 , PF_3 and ClF_3 is :

- (1) $\text{PF}_3 < \text{BF}_3 < \text{ClF}_3$
- (2) $\text{BF}_3 < \text{PF}_3 < \text{ClF}_3$
- (3) $\text{ClF}_3 < \text{PF}_3 < \text{BF}_3$
- (4) $\text{BF}_3 = \text{PF}_3 < \text{ClF}_3$

Ans. (3)

Sol.

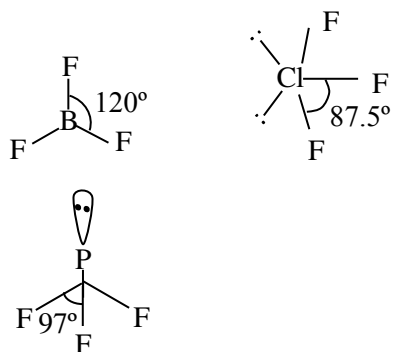

Order of bond angle is
 $\text{ClF}_3 < \text{PF}_3 < \text{BF}_3$

65. Match List I with List II

LIST-I (Test)		LIST-II (Observation)	
A.	Br_2 water test	I.	Yellow orange or orange red precipitate formed
B.	Ceric ammonium nitrate test	II.	Reddish orange colour disappears
C.	Ferric chloride test	III.	Red colour appears
D.	2, 4-DNP test	IV.	Blue, Green, Violet or Red colour appear

Choose the correct answer from the options given below:

- (1) A-I, B-II, C-III, D-IV
- (2) A-II, B-III, C-IV, D-I
- (3) A-III, B-IV, C-I, D-II
- (4) A-IV, B-I, C-II, D-III

Ans. (2)

Sol. (A) Br_2 water test is test of unsaturation in which reddish orange colour of bromine water disappears.

(B) Alcohols given Red colour with ceric ammonium nitrate.

(C) Phenol gives Violet colour with natural ferric chloride.

(D) Aldehyde & Ketone give Yellow/Orange/Red Colour compounds with 2, 4-DNP i.e., 2, 4-Dinitrophenyl hydrazine.

66. Match List I with List II

LIST-I (Cell)		LIST-II (Use/Property/Reaction)	
A.	Leclanche cell	I.	Converts energy of combustion into electrical energy
B.	Ni-Cd cell	II.	Does not involve any ion in solution and is used in hearing aids
C.	Fuel cell	III.	Rechargeable
D.	Mercury cell	IV.	Reaction at anode $\text{Zn} \rightarrow \text{Zn}^{2+} + 2\text{e}^-$

Choose the correct answer from the options given below:

- (1) A-I, B-II, C-III, D-IV
- (2) A-III, B-I, C-IV, D-II
- (3) A-IV, B-III, C-I, D-II
- (4) A-II, B-III, C-IV, D-I

Ans. (3)

Sol. A-IV, B-III, C-I, D-II

67. Match List I with List II

LIST-I		LIST-II	
A.	$\text{K}_2[\text{Ni}(\text{CN})_4]$	I.	sp^3
B.	$[\text{Ni}(\text{CO})_4]$	II.	sp^3d^2
C.	$[\text{Co}(\text{NH}_3)_6]\text{Cl}_3$	III.	dsp^2
D.	$\text{Na}_3[\text{CoF}_6]$	IV.	d^2sp^3

Choose the correct answer from the options given below:

- (1) A-III, B-I, C-II, D-IV
- (2) A-III, B-II, C-IV, D-I
- (3) A-I, B-III, C-II, D-IV
- (4) A-III, B-I, C-IV, D-II

Ans. (4)

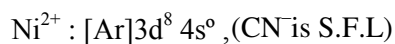
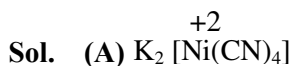

Pre hybridization state of Ni^{+2}

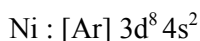
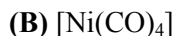
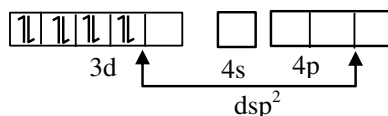

CO is S.F.L, so pairing occur

Pre hybridization state of Ni

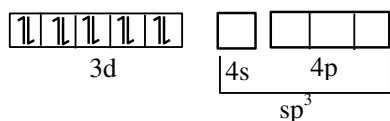

With Co^{3+} , NH_3 act as S.F.L

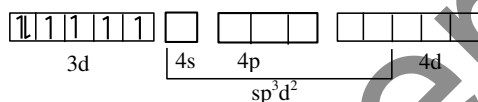
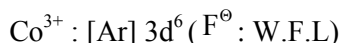
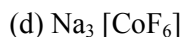
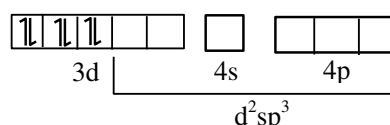

68. The coordination environment of Ca^{2+} ion in its complex with $EDTA^{4-}$ is :

- (1) tetrahedral
- (2) octahedral
- (3) square planar
- (4) trigonal prismatic

Ans. (2)

Sol. $EDTA^{4-} \rightarrow$ Hexadentate ligand



So Coordination environment is octahedral

69. The **incorrect** statement about Glucose is :

- (1) Glucose is soluble in water because of having aldehyde functional group
- (2) Glucose remains in multiple isomeric form in its aqueous solution
- (3) Glucose is an aldohexose
- (4) Glucose is one of the monomer unit in sucrose

Ans. (1)

Sol. Glucose is soluble in water due to presence of alcohol functional group and extensive hydrogen bonding.

Glucose exist is open chain as well as cyclic forms in its aqueous solution.

Glucose having 6C atoms so it is hexose and having aldehyde functional group so it is aldose.

Thus, aldohexose.

Glucose is monomer unit in sucrose with fructose.

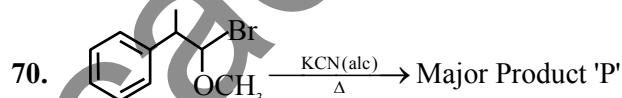

In the above reaction product 'P' is

- (1)
- (2)
- (3)
- (4)

Ans. (1)

Sol.

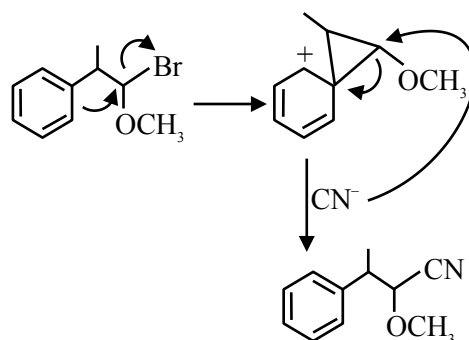

Due to NGP effect of phenyl ring Nucleophilic substitution of Br will occurs.

71. Which of the following compound can give positive iodoform test when treated with aqueous KOH solution followed by potassium hypoiodite.

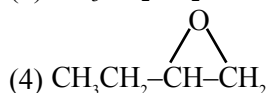
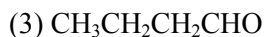
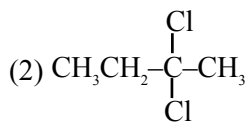
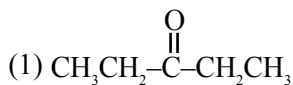

Ans. (2)

Sol.

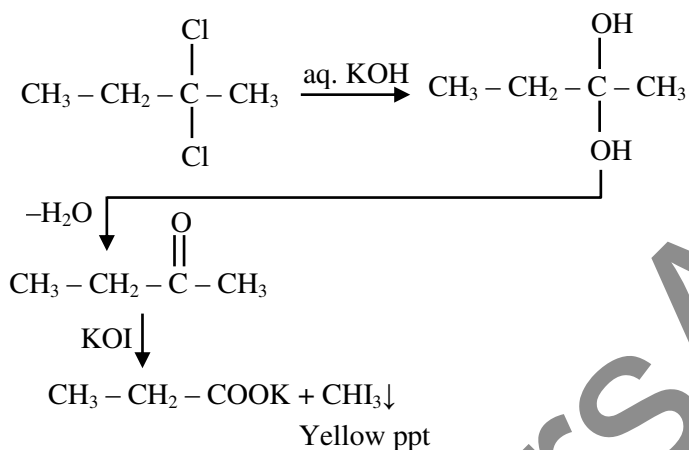

72. For a sparingly soluble salt AB_2 , the equilibrium concentrations of A^{2+} ions and B^- ions are $1.2 \times 10^{-4} \text{ M}$ and $0.24 \times 10^{-3} \text{ M}$, respectively. The solubility product of AB_2 is :

(1) 0.069×10^{-12}

(2) 6.91×10^{-12}

(3) 0.276×10^{-12}

(4) 27.65×10^{-12}

Ans. (2)

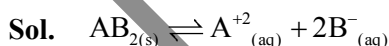

$$K_{sp} = [\text{A}^{+2}][\text{B}^-]^2$$

$$= 1.2 \times 10^{-4} \times (2.4 \times 10^{-4})^2$$

$$= 6.91 \times 10^{-12} \text{ M}^3$$

73. Major product of the following reaction is

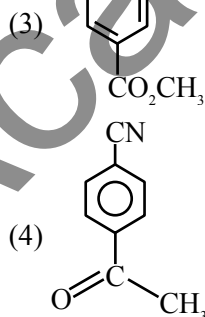
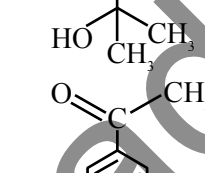
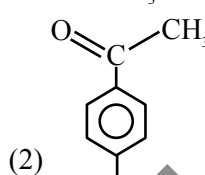
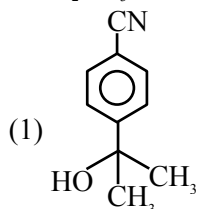
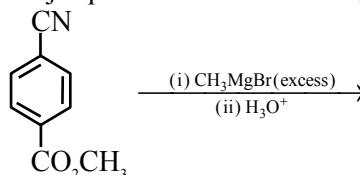

Ans. (2)

Sol.

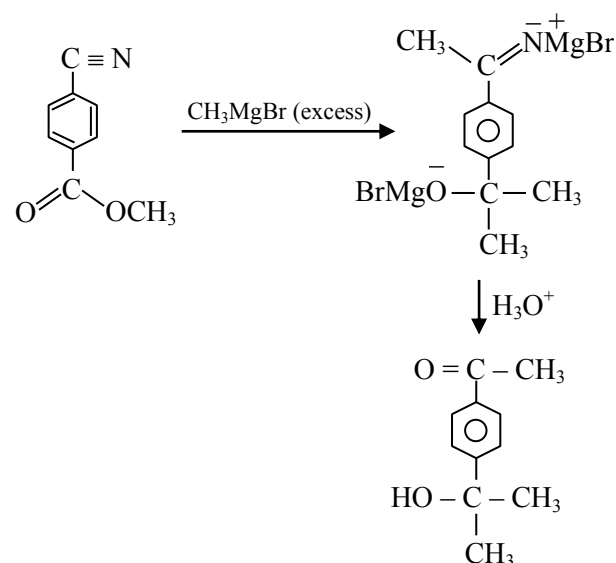

74. Given below are two statements :

Statement I : The higher oxidation states are more stable down the group among transition elements unlike p-block elements.

Statement II : Copper can not liberate hydrogen from weak acids.

In the light of the above statements, choose the correct answer from the options given below :

- (1) Both Statement I and Statement II are false
- (2) Statement I is false but Statement II is true
- (3) Both Statement I and Statement II are true
- (4) Statement I is true but Statement II is false

Ans. (3)

Sol. On moving down the group in transition elements, stability of higher oxidation state increases, due to increase in effective nuclear charge.

$$\Rightarrow E^{\circ}_{\text{Cu}^{+2}/\text{Cu}} = 0.34 \text{ V}$$

$$\Rightarrow E^{\circ}_{\text{H}^{+}/\text{H}_2} = 0$$



Cu can't liberate hydrogen gas from weak acid.

75. The **incorrect** statement regarding ethyne is

- (1) The C–C bonds in ethyne is shorter than that in ethene
- (2) Both carbons are sp hybridised
- (3) Ethyne is linear
- (4) The carbon-carbon bonds in ethyne is weaker than that in ethene

Ans. (4)

Sol. The carbon-carbon bonds in ethyne is stronger than that in ethene.

(H–C≡C–H) Ethyne is linear and carbon atoms are SP hybridised.

76. Match List I with List II

List-I (Element)		List-II (Electronic Configuration)	
A.	N	I.	[Ar] 3d ¹⁰ 4s ² 4p ⁵
B.	S	II.	[Ne] 3s ² 3p ⁴
C.	Br	III.	[He] 2s ² 2p ³
D	Kr	IV.	[Ar] 3d ¹⁰ 4s ² 4p ⁶

Choose the correct answer from the options given below :

- (1) A-IV, B-III, C-II, D-I
- (2) A-III, B-II, C-I, D-IV
- (3) A-I, B-IV, C-III, D-II
- (4) A-II, B-I, C-IV, D-III

Ans. (2)

- Sol.** (A) ${}_{7}\text{N} : [\text{He}]2s^2 2p^3$
 (B) ${}_{16}\text{S} : [\text{Ne}]2s^2 3p^4$
 (C) ${}_{35}\text{Br} : [\text{Ar}]3d^{10} 4s^2 4p^5$
 (D) ${}_{36}\text{Kr} : [\text{Ar}]3d^{10} 4s^2 4p^6$

77. Match List I with List II

List-I		List-II	
A.	Melting point [K]	I.	Tl > In > Ga > Al > B
B.	Ionic Radius [M ⁺³ /pm]	II.	B > Tl > Al ≈ Ga > In
C.	Δ _f H ₁ [kJ mol ⁻¹]	III.	Tl > In > Al > Ga > B
D	Atomic Radius [pm]	IV.	B > Al > Tl > In > Ga

Choose the correct answer from the options given below :

- (1) A-III, B-IV, C-I, D-II
- (2) A-II, B-III, C-IV, D-I
- (3) A-IV, B-I, C-II, D-III
- (4) A-I, B-II, C-III, D-IV

Ans. (3)

Sol. Melting point : $B > Al > Tl > In > Ga$

Ionic radius (M^{+3}/pm) : $Tl > In > Ga > Al > B$

$(\Delta_{IE}H)_1 \left[\frac{kJ}{mol} \right]$: $B > Tl > Al \approx Ga > In$

Atomic radius (in pm) : $Tl > In > Al > Ga > B$

78. Which of the following compounds will give silver mirror with ammoniacal silver nitrate?

- (A) Formic acid
(B) Formaldehyde
(C) Benzaldehyde
(D) Acetone

Choose the correct answer from the options given below :

- (1) C and D only
(2) A, B and C only
(3) A only
(4) B and C only

Ans. (2)

Sol. Apart from aldehyde, Formic acid



also gives silver mirror test with ammoniacal silver nitrate.

79. Which out of the following is a correct equation to show change in molar conductivity with respect to concentration for a weak electrolyte, if the symbols carry their usual meaning :

(1) $\Lambda_m^2 C - K_a \Lambda_m^{\circ 2} + K_a \Lambda_m \Lambda_m^{\circ} = 0$

(2) $\Lambda_m - \Lambda_m^{\circ} + AC^{\frac{1}{2}} = 0$

(3) $\Lambda_m - \Lambda_m^{\circ} - AC^{\frac{1}{2}} = 0$

(4) $\Lambda_m^2 C + K_a \Lambda_m^{\circ 2} - K_a \Lambda_m \Lambda_m^{\circ} = 0$

Ans. (1)

Sol. $HA(aq) \rightleftharpoons H^+(aq) + A^-(aq)$

$$K_a = \frac{\alpha^2 C}{1 - \alpha}$$

$$\alpha^2 C + K_a \alpha - K_a = 0$$

$$\left(\frac{\lambda_m}{\lambda_m^{\infty}} \right)^2 C + K_a \frac{\lambda_m}{\lambda_m^{\infty}} - K_a = 0$$

$$\lambda_m^2 C + K_a \lambda_m \lambda_m^{\infty} - K_a (\lambda_m^{\infty})^2 = 0$$

80. The electronic configuration of Einsteinium is :
(Given atomic number of Einsteinium = 99)

- (1) $[Rn] 5f^{12} 6d^0 7s^2$ (2) $[Rn] 5f^{11} 6d^0 7s^2$
(3) $[Rn] 5f^{13} 6d^0 7s^2$ (4) $[Rn] 5f^{10} 6d^0 7s^2$

Ans. (2)

Sol. Einsteinium (atomic No = 99) : $[Rn] 5f^{11} 6d^0 7s^2$

SECTION-B

81. Number of oxygen atoms present in chemical formula of fuming sulphuric acid is _____.

Ans. (7)

Sol. Fuming sulphuric acid is a mixture of
conc. $H_2SO_4 + SO_3$ Or $H_2S_2O_7$

So, Number of Oxygen atoms = 7

82. A transition metal 'M' among Sc, Ti, V, Cr, Mn and Fe has the highest second ionisation enthalpy. The spin only magnetic moment value of M^+ ion is _____ BM (Near integer)

(Given atomic number Sc : 21, Ti : 22, V : 23, Cr : 24, Mn : 25, Fe : 26)

Ans. (6)

Sol. Among given metals, Cr has maximum IE_2 because Second electron is removed from stable configuration $3d^5$

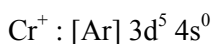

\therefore No of unpaired e^- in Cr^+ is 5, $n = 5$

So, Magnetic moment = $\sqrt{n(n+2)}$ B.M

$$= \sqrt{5(5+2)} = 5.92 \text{ BM} \approx 6$$

83. The vapour pressure of pure benzene and methyl benzene at 27°C is given as 80 Torr and 24 Torr, respectively. The mole fraction of methyl benzene in vapour phase, in equilibrium with an equimolar mixture of those two liquids (ideal solution) at the same temperature is $____ \times 10^{-2}$ (nearest integer)

Ans. (23)

Sol. $X_{\text{methylbenzene}} = 0.5$

$$Y_{\text{methylbenzene}} = \frac{P_{\text{methylbenzene}}}{P_{\text{total}}}$$

$$Y_{\text{methylbenzene}} = \frac{0.5 \times 24}{0.5 \times 80 + 0.5 \times 24}$$

$$= \frac{12}{40 + 12} = 0.23 = 23 \times 10^{-2}$$

84. Consider the following test for a group-IV cation.

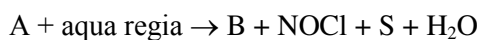
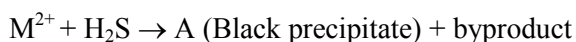

The spin only magnetic moment value of the metal complex C is $______ \text{ BM}$.

(Nearest integer)

Ans. (0)

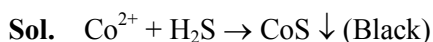

(A)



(A) (B)



↓



In $K_3[Co(NO_2)_6]$, $Co^{+3} : 3d^6 4s^0$

$Co^{3+} : d^2sp^3$ Hybridisation

Number of unpaired $e^- = 0$

Magnetic moment = $\sqrt{n(n+2)} = 0 \text{ B.M}$

85. Consider the following first order gas phase reaction at constant temperature

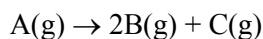

If the total pressure of the gases is found to be 200 torr after 23 sec. and 300 torr upon the complete decomposition of A after a very long time, then the rate constant of the given reaction is $____ \times 10^{-2} \text{ s}^{-1}$ (nearest integer)

[Given : $\log_{10}(2) = 0.301$]

Ans. (3)

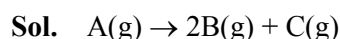

$$P_{23} = P_0 + 2x = 200$$

$$P_{\infty} = 3P_0 = 300$$

$$P_0 = 100$$

$$K = \frac{1}{t} \ln \frac{P_{\infty} - P_0}{P_{\infty} - P_t}$$

$$K = \frac{2.3}{23} \log \frac{300 - 100}{300 - 200}$$

$$= \frac{2.3 \times 0.301}{23} = 0.0301 = 3.01 \times 10^{-2} \text{ sec}^{-1}$$

86.

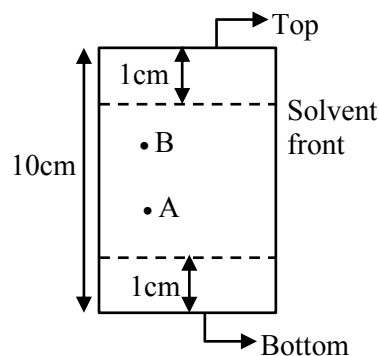

In the given TLC, the distance of spot A & B are 5 cm & 7 cm, from the bottom of TLC plate, respectively.

R_f value of B is $x \times 10^{-1}$ times more than A. The value of x is $______$.

Ans. (15)

Sol.

$$R_f = \frac{\text{Distance moved by substance from base line}}{\text{Distance moved by solvent from base line}}$$

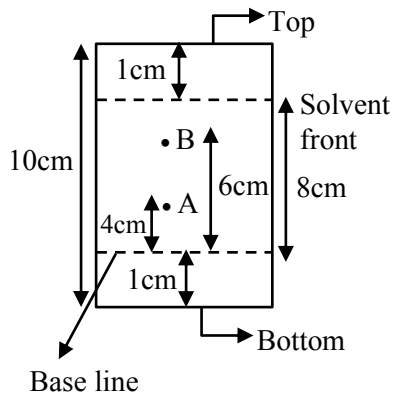

$$(R_f)_A = \frac{4}{8} \quad (R_f)_B = \frac{6}{8}$$

$$\frac{(R_f)_B}{(R_f)_A} = \frac{6}{8} \times \frac{8}{4}$$

$$(R_f)_B = 1.5 (R_f)_A$$

$$x = 15$$

87. Based on Heisenberg's uncertainty principle, the uncertainty in the velocity of the electron to be found within an atomic nucleus of diameter 10^{-15} m is _____ $\times 10^9$ ms^{-1} (nearest integer)

[Given : mass of electron = 9.1×10^{-31} kg, Planck's constant (h) = 6.626×10^{-34} Js]

(Value of $\pi = 3.14$)

Ans. (58)

$$\text{Sol. } m\Delta V \cdot \Delta x = \frac{h}{4\pi}$$

$$\Delta V = \frac{6.626 \times 10^{-34}}{9.1 \times 10^{-31} \times 10^{-15} \times 4 \times 3.14}$$

$$= 57.97 \times 10^9 \text{ m/sec}$$

88. Number of compounds from the following which **cannot** undergo Friedel-Crafts reactions is : _____ toluene, nitrobenzene, xylene, cumene, aniline, chlorobenzene, m-nitroaniline, m-dinitrobenzene

Ans. (4)

Sol. Compounds which can not undergo Friedel Crafts reaction are

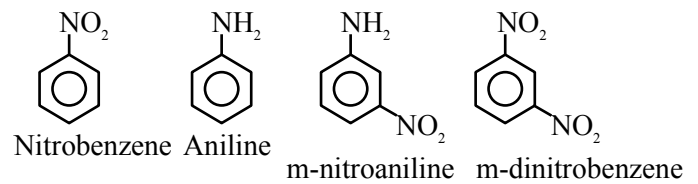

89. Total number of electron present in (π^*) molecular orbitals of O_2 , O_2^+ and O_2^- is _____.

Ans. (6)

$$\text{Sol. } \text{O}_2 (16e) : (\sigma_{1s})^2 (\sigma_{1s}^*)^2 (\sigma_{2s})^2 (\sigma_{2s}^*)^2$$

$$(\sigma_{2p})^2 [(\pi_{2p})^2 = (\pi_{2p}^*)^2] [(\pi_{2p}^*)^1 = (\pi_{2p}^*)^1]$$

Number of e^- present in (π^*) of $\text{O}_2 = 2$

Number of e^- present in (π^*) of $\text{O}_2^+ = 1$

Number of e^- present in (π^*) of $\text{O}_2^- = 3$

So total e^- in (π^*) = $2 + 1 + 3 = 6$

90. When $\Delta H_{\text{vap}} = 30$ kJ/mol and $\Delta S_{\text{vap}} = 75$ J mol^{-1} K^{-1} , then the temperature of vapour, at one atmosphere is _____ K.

Ans. (400)

Sol. At equilibrium $\Delta G_{\text{PT}} = 0$

$$\Delta H_{\text{vap}} = T\Delta S_{\text{vap}}$$

$$30 \times 1000 = T \times 75$$

$$T = 400\text{K}$$